



**647563 EN (22/08/2017)**

MT 1435 EASY 75D ST3B S1  
MT 1440 EASY 75D ST3B S1  
MT 1840 EASY 75D ST3B S1

**OPERATOR'S MANUAL**  
*(ORIGINAL INSTRUCTIONS)*

## **IMPORTANT**

*Carefully read and understand this instruction manual before using the lift truck.*

*It contains all information relating to operation, handling and lift truck equipment,  
as well as important recommendations to be followed.*

*This document also contains precautions for use, as well as information on the servicing and routine maintenance required  
to ensure the lift truck's continued safety of use and reliability.*

**WHENEVER YOU SEE THIS SYMBOL IT MEANS:**



**WARNING ! BE CAREFUL ! YOUR SAFETY OR THE SAFETY OF THE LIFT TRUCK IS AT RISK.**

- This manual has been produced on the basis of the equipment list and the technical characteristics given at the time of its design.
- The level of equipment of the lift truck depends on the options chosen and the country of sale.
- According to the lift truck options and the date of sale, certain items of equipment/functions described herein may not be available.
- Descriptions and figures are non binding.
- MANITOU reserves the right to change its models and their equipment without being required to update this manual.
- The MANITOU network, consisting exclusively of qualified professionals, is at your disposal to answer all your questions.
- This manual is an integral part of the lift truck.
- It is to be kept in its storage space at all times for ease of reference.
- Hand this manual to the new owner if the lift truck is resold.

1st ISSUE	08/06/2016	
UPDATED	22/08/2017	2-44 – 2-47

Manitou BF S.A Limited liability company with a Board of Directors.  
 Head office: 430, Rue de l'Aubinière - 44150 Ancenis - FRANCE  
 Share capital: 39,548,949 euros  
 857 802 508 RCS Nantes.  
 Tel: +33 (0)2 40 09 10 11  
[www.manitou.com](http://www.manitou.com)

*This manual is for information purposes only. Any reproduction, copy, representation, recording, transfer, distribution, or other, in part or in whole, in any format is prohibited. The plans, designs, views, commentaries and instructions, even the document organization that are found in this document, are the intellectual property of MANITOU BF. Any violation of the aforementioned may lead to civil and criminal prosecution. The logos as well as the visual identity of the company are the property of MANITOU BF and may not be used without express and formal authorization. All rights are reserved.*

**1 - OPERATING AND SAFETY INSTRUCTIONS**

**2 - DESCRIPTION**

**3 - MAINTENANCE**

**4 - OPTIONAL ATTACHMENTS FOR USE WITH THE RANGE**



# ***1 - OPERATING AND SAFETY INSTRUCTIONS***



# ASSISTANCE | 23 SIMPLE TIPS

The Manitou Group wishes to assist you in reducing the consumption of the machines to help you reduce your carbon footprint.



Chose a machine with an appropriate power rating for your needs.



Switch off your engine after running at idle for more than 3 minutes.



Optimum engine efficiency is achieved at the maximum torque engine speed.



Preferably use a fan control and reversal system.



Favor "smart" electronically-managed transmissions.



Use the air-conditioning with windows and doors closed.



Preferably use LED headlights.



Adapt the type of tire to your environment.



Ensure that your tires are inflated to the correct pressure.



Check the parking brake adjustment.

## Preferably use manufacturer-recommended attachments



Check the general condition of your trailer.



Adapt your maximum towable load.



Use the attachments that are suitable for your machine.



Check the hydraulic adjustment of your attachments.



Observe the maintenance periods.



Regularly clean the radiator, the air filter, etc.



Lubricate regularly.



Preferably buy through a manufacturer-approved dealer.



Favor OEM parts.



Study the manufacturers' maintenance contracts.



You can follow eco-driving courses.



Demand to know the consumption and emissions of the machines.



Calculate your consumption and emissions at [reduce.manitou.com](http://reduce.manitou.com)

# TABLE OF CONTENTS

## 1 - OPERATING AND SAFETY INSTRUCTIONS

<b>INSTRUCTIONS TO THE COMPANY MANAGER</b>	<b>6</b>
<b>THE SITE</b>	<b>6</b>
<b>THE OPERATOR</b>	<b>6</b>
<b>THE LIFT TRUCK</b>	<b>6</b>
A - THE TRUCK'S SUITABILITY FOR THE JOB . . . . .	6
B - ADAPTATION OF THE LIFT TRUCK TO STANDARD ENVIRONMENTAL CONDITIONS . . . . .	6
C - MODIFICATION OF THE LIFT TRUCK . . . . .	7
D - FRENCH ROAD TRAFFIC RULES. . . . .	7
E - LIFT TRUCK CAB PROTECTION. . . . .	7
<b>THE INSTRUCTIONS</b>	<b>7</b>
<b>THE MAINTENANCE</b>	<b>7</b>
<b>INSTRUCTIONS FOR THE OPERATOR</b>	<b>8</b>
<b>PREAMBLE</b>	<b>8</b>
<b>GENERAL INSTRUCTIONS</b>	<b>8</b>
A - OPERATOR'S MANUAL . . . . .	8
B - AUTHORISATION FOR USE IN FRANCE . . . . .	8
C - MAINTENANCE . . . . .	8
D - MODIFICATION OF THE LIFT TRUCK . . . . .	8
E - LIFTING PEOPLE . . . . .	9
<b>OPERATING INSTRUCTIONS UNLADEN AND LADEN</b>	<b>9</b>
A - BEFORE STARTING THE LIFT TRUCK . . . . .	9
B - DRIVER'S OPERATING INSTRUCTIONS . . . . .	9
C - ENVIRONMENT . . . . .	9
D - VISIBILITY . . . . .	10
E - STARTING THE LIFT TRUCK. . . . .	11
F - DRIVING THE LIFT TRUCK. . . . .	11
G - STOPPING THE LIFT TRUCK . . . . .	12
H - DRIVING THE LIFT TRUCK ON THE PUBLIC HIGHWAY . . . . .	13
<b>INSTRUCTIONS FOR HANDLING A LOAD</b>	<b>14</b>
A - CHOICE OF ATTACHMENTS . . . . .	14
B - MASS OF LOAD AND CENTRE OF GRAVITY. . . . .	14
C - LONGITUDINAL STABILITY LIMITER AND WARNING DEVICE. . . . .	14
D - TRANSVERSE ATTITUDE OF THE LIFT TRUCK. . . . .	15
E - TAKING UP A LOAD ON THE GROUND. . . . .	15
F - TAKING UP AND LAYING A HIGH LOAD ON TYRES . . . . .	16
G - TAKING UP AND LAYING A HIGH LOAD ON STABILIZERS. . . . .	18
H - TAKING UP AND LAYING DOWN A SUSPENDED LOAD . . . . .	20
I - TRAVELLING WITH A SUSPENDED LOAD. . . . .	20
<b>PLATFORM OPERATING INSTRUCTIONS</b>	<b>21</b>
A - AUTHORISATION FOR USE. . . . .	21
B - LIFT TRUCK SUITABILITY FOR USE . . . . .	21
C - PRECAUTIONS WHEN USING THE PLATFORM . . . . .	21
D - USING THE PLATFORM . . . . .	21
E - ENVIRONMENT . . . . .	21
F - MAINTENANCE . . . . .	22
<b>INSTRUCTIONS FOR USING THE RADIO-CONTROL</b>	<b>23</b>
HOW TO USE THE RADIO-CONTROL . . . . .	23
PROTECTIVE DEVICES . . . . .	23



<b><i>LIFT TRUCK MAINTENANCE INSTRUCTIONS</i></b>	<b>24</b>
<b>GENERAL INSTRUCTIONS</b>	<b>24</b>
<b>PLACING THE JIB SAFETY WEDGE</b>	<b>24</b>
FITTING THE WEDGE. . . . .	24
REMOVING THE WEDGE . . . . .	24
<b>MAINTENANCE</b>	<b>24</b>
MAINTENANCE LOGBOOK. . . . .	24
<b>LUBRICANT AND FUEL LEVELS</b>	<b>25</b>
<b>HYDRAULIC</b>	<b>25</b>
<b>ELECTRICITY</b>	<b>25</b>
<b>WELDING</b>	<b>25</b>
<b>WASHING THE LIFT TRUCK</b>	<b>25</b>
<b>TRANSPORTING THE LIFT TRUCK</b>	<b>25</b>
<b><i>IF THE LIFT TRUCK IS NOT TO BE USED FOR A LONG TIME</i></b>	<b>26</b>
<b>INTRODUCTION</b>	<b>26</b>
<b>PREPARING THE LIFT TRUCK</b>	<b>26</b>
<b>PROTECTING THE ENGINE</b>	<b>26</b>
<b>PROTECTING THE LIFT TRUCK</b>	<b>26</b>
<b>BRINGING THE LIFT TRUCK BACK INTO SERVICE</b>	<b>26</b>
<b><i>LIFT TRUCK DISPOSAL</i></b>	<b>27</b>
<b>RECYCLING OF MATERIALS</b>	<b>27</b>
METALS. . . . .	27
PLASTICS. . . . .	27
RUBBER. . . . .	27
GLASS. . . . .	27
<b>ENVIRONMENTAL PROTECTION</b>	<b>27</b>
WORN OR DAMAGED PARTS . . . . .	27
USED OIL. . . . .	27
USED BATTERIES . . . . .	27

# INSTRUCTIONS TO THE COMPANY MANAGER

## THE SITE

Proper management of lift truck's area of travel will reduce the risk of accidents:

- ground not unnecessarily uneven or obstructed,
- no excessive slopes,
- pedestrian traffic controlled, etc.

## THE OPERATOR

- Only qualified, authorized personnel can use the lift truck. This authorization is given in writing by the appropriate person in the establishment with respect to the use of lift trucks and must be carried permanently by the operator.

### ⚠ IMPORTANT ⚠

*Experience has shown that there are a number of inappropriate ways in which the lift truck might be used. Such foreseeable misuse, of which the main examples are listed below, are strictly forbidden.*

- *The foreseeable abnormal behaviour resulting from ordinary negligence, but which does not result from any wish to put the machinery to any improper use.*
  - *The reflex reactions of a person in the event of a malfunction, incident, fault, etc. during operation of the lift truck.*
  - *Behaviour resulting from application of the "principle of least effort" when performing a task.*
  - *For certain machines, the foreseeable behaviour of such persons as: apprentices, teenagers, handicapped persons, trainees tempted to drive a lift truck, operators tempted to operate a truck for the purposes of a bet, a competition or for their own personal experience.*
- The person in charge of the equipment must take these criteria into account when assessing the suitability of a person to drive.*

## THE LIFT TRUCK

### A - THE TRUCK'S SUITABILITY FOR THE JOB

- MANITOU has ensured that this lift truck is suitable for use under the standard operating conditions defined in this operator's manual, with a **STATIC** test coefficient **OF 1,33** and a **DYNAMIC** test coefficient **OF 1**, as specified in harmonised standard **EN 1459** for variable range trucks.
- Before commissioning, the company manager must make sure that the lift truck is appropriate for the work to be done, and perform certain tests (in accordance with current legislation).

### B - ADAPTATION OF THE LIFT TRUCK TO STANDARD ENVIRONMENTAL CONDITIONS

- In addition to series equipment mounted on your lift truck, many options are available, such as: road lighting, stop lights, revolving light, reverse lights, reverse buzzer alarm, front light, rear light, light at the jib head, etc. (according to the lift truck model).
- The operator must take into account the operating conditions to define the lift truck's signalling and lighting equipment. Contact your dealer.
- Take into account climatic and atmospheric conditions of the site of utilisation.
  - Protection against frost (see: 3 - MAINTENANCE: LUBRICANTS AND FUEL).
  - Adaptation of lubricants (ask your dealer for information).
  - Engine filtration (see: 3 - MAINTENANCE: FILTERS CARTRIDGES AND BELTS).

### ⚠ IMPORTANT ⚠

*For operation under average climatic conditions, i.e.: between -15 °C and +35 °C, correct levels of lubricants in all the circuits are checked in production.*  
*For operation under more severe climatic conditions, before starting up, it is necessary to drain all the circuits, then ensure correct levels of lubricants using lubricants properly suited to the relevant ambient temperatures.*  
*The same applies to the cooling liquid.*

- A lift truck operating in an area without fire extinguishing equipment must be equipped with an individual extinguisher. There are solutions, consult your dealer.

### ⚠ IMPORTANT ⚠

*Your lift truck is designed for outdoor use under normal atmospheric conditions and indoor use in suitably aerated and ventilated premises.*  
*It is prohibited to use the lift truck in areas where there is a risk of fire or which are potentially explosive (e.g. Refineries, fuel or gas depots, stores of flammable products, etc.).*  
*For use in these areas, specific equipment is available (ask your dealer for information).*

- Our trucks comply with Directive 2004/108/EC concerning electromagnetic compatibility (EMC), and with the corresponding harmonized standard EN 12895. Their proper operation is no longer guaranteed if they are used within areas in which the electromagnetic fields exceed the limit specified by that standard (10 V/m).
- Directive 2002/44/EC requires company managers to not expose their employees to excessive vibration doses. There is no recognized code of measurement for comparing the machines of different manufacturers. The actual doses received cannot therefore be measured under actual operating conditions at the user's premises.
- The following are some tips for minimizing these vibration doses:
  - Select the most suitable lift truck and attachment for the intended use.

- Adapt the seat adjustment to the operator's weight (according to lift truck model) and maintain it in good condition, as well as the cab suspension. Inflate the tires in accordance with recommendations.
- Ensure that the operators adapt their operating speed to suit the conditions on site.
- As far as possible, arrange the site in such a way as to provide a flat running surface and remove obstacles and harmful potholes.

### C - MODIFICATION OF THE LIFT TRUCK

- For your safety and that of others, you must not change the structure and settings of the various components used in your lift truck (hydraulic pressure, calibrating limiters, engine speed, addition of extra equipment, addition of counterweight, unapproved attachments, alarm systems, etc.) yourself. In this event, the manufacturer cannot be held responsible.

### D - FRENCH ROAD TRAFFIC RULES

(or see current legislation in other countries)

- Only one certificate of conformity is issued. It must be kept in a safe place.
- The driving of non EC type-approved tractors on the public highway is subject to the provisions of the highway code relating to special machines, defined in article R311-1 of the highway code, in category B of the Equipment Order of 20 November 1969 that determines the procedures applicable to special machines. The lift truck must be fitted with a licence plate.
- The driving of EC type-approved tractors on the public highway is subject to the provisions of the highway code regarding agricultural tractors, defined in article R311-1 of the highway code. The lift truck must be registered.

### SPECIAL INSTRUCTION APPLYING TO "EC TRACTOR" TYPE-APPROVED LIFT TRUCKS

- All EC tractor type-approved lift trucks are supplied with an "EC tractor" certificate complying with directive 2003/37/EC, to be retained by the owner, and a page of administrative details together with a CNIT number (national type approval code) for registration at the prefecture.
- The lift truck owner is responsible for carrying out the necessary procedures for obtaining the vehicle registration document within the time limit defined by the regulations.
- The operator must hold an HGV licence, unless granted an exemption.
- The lift truck must be driven on the public highway in accordance with the instructions given in the manual supplied with the lift truck (Gross weight, Gross combination weight, towing load, axle loads, maximum speeds, etc. according to type/version). The operator must be in possession of the lift truck's registration document.

#### **⚠ IMPORTANT ⚠**

*When towing a trailer or agricultural equipment, the travelling speed of the lift truck is limited to 25 km/h.  
In this case, a "25" disc must be affixed to the rear of the convoy.*

### E - LIFT TRUCK CAB PROTECTION

- All lift trucks comply with the requirements of ISO 3471 (wheel loader code) regarding cab rollover protection (ROPS) and ISO 3449 (Level II) regarding the protection of the cab against falling objects (FOPS).
- "EC TRACTOR" type-approved lift trucks comply, in addition, with Directive 79/622/EC (OECD Code 4) regarding cab rollover protection (ROPS).

#### **⚠ IMPORTANT ⚠**

*Structural damage or overturning, a modification, changes or a poorly executed repair can reduce the protective efficiency of the cab, cancelling its compliance.  
Do not perform welding or drilling on the cab structure.  
Consult your dealer to determine the limits of this structure without cancelling its compliance.*

## THE INSTRUCTIONS

- The operator's manual must always be in good condition and kept in the place provided on the lift truck and in the language used by the operator.
- The operator's manual and any plates or stickers which are no longer legible or are damaged, must be replaced immediately.

## THE MAINTENANCE

- Maintenance or repairs other than those detailed in part: 3 - MAINTENANCE must be carried out by qualified personnel (consult your dealer) and under the necessary safety conditions to maintain the health of the operator and any third party.

#### **⚠ IMPORTANT ⚠**

*Your lift truck must be inspected periodically to ensure that it remains in compliance.  
The frequency of this inspection is defined by current legislation in the country in which the lift truck is used.*

- Example for France "The manager in charge of the establishment using a lift truck must open and maintain a maintenance log for each machine (order of 2 March 2004) and undergo a general periodic inspection every 6 months (order of 1 March 2004)".

# INSTRUCTIONS FOR THE OPERATOR

## PREAMBLE

### **⚠ IMPORTANT ⚠**

*The risk of accident while using, servicing or repairing your lift truck can be restricted if you follow the safety instructions and safety measures detailed in these instruction. Failure to respect the safety and operating instructions, or the instructions for repairing or servicing your lift truck may lead to serious, even fatal accident.*

- Only the operations and manoeuvres described in these operator's manual must be performed. The manufacturer cannot predict all possible risky situations. Consequently, the safety instructions given in the operator's manual and on the lift truck itself are not exhaustive.
- At any time, as an operator, you must envisage, within reason, the possible risk to yourself, to others or to the lift truck itself when you use it.

### **⚠ IMPORTANT ⚠**

*In order to reduce or avoid any danger with a MANITOU-approved attachment, follow the instructions of paragraph:  
4 - ADAPTABLE ATTACHMENTS IN OPTION ON THE RANGE: INTRODUCTION.*

## GENERAL INSTRUCTIONS

### A - OPERATOR'S MANUAL

- Read the operator's manual carefully.
- The operator's manual must always be in good condition and in the place provided for it on the lift truck.
- You must report any plates and stickers which are no longer legible or which are damaged.

### B - AUTHORISATION FOR USE IN FRANCE

*(or see current legislation in other countries).*

- Only qualified, authorized personnel can use the lift truck. This authorization is given in writing by the appropriate person in the establishment with respect to the use of lift trucks and must be carried permanently by the operator.
- The operator is not competent to authorise the driving of the lift truck by another person.

### C - MAINTENANCE

- The operator must immediately advise his superior if his lift truck is not in good working order or does not comply with the safety notice.
- The operator is prohibited from carrying out any repairs or adjustments himself, unless he has been trained for this purpose. He must keep the lift truck properly cleaned if this is among his responsibilities.
- The operator must carry out daily maintenance (see: 3 - MAINTENANCE: A - DAILY OR EVERY 10 HOURS SERVICE).
- The operator must ensure tyres are adapted to the nature of the ground (see area of the contact surface of the tyres in the chapter: 2 - DESCRIPTION: TYRES). There are optional solutions, consult your dealer.
  - SAND tyres.
  - LAND tyres.
  - Snow chains.

### **⚠ IMPORTANT ⚠**

*Do not use the lift truck if the tyres are incorrectly inflated, damaged or excessively worn, because this could put your own safety or that of others at risk, or cause damage to the lift truck itself.*

*The fitting of foam inflated tyres is prohibited and is not guaranteed by the manufacturer, excepting prior authorisation.*

### D - MODIFICATION OF THE LIFT TRUCK

- For your safety and that of others, you must not change the structure and settings of the various components used in your lift truck (hydraulic pressure, calibrating limiters, engine speed, addition of extra equipment, addition of counterweight, unapproved attachments, alarm systems, etc.) yourself. In this event, the manufacturer cannot be held responsible.

## E - LIFTING PEOPLE

- The use of working equipment and load lifting attachments to lift people is:
  - either forbidden
  - or authorized exceptionally and under certain conditions (see current regulations in the country in which the lift truck is used).
- The pictogram posted at the operator station reminds you that:
  - Left-hand column
    - It is forbidden to lift people, with any kind of attachment, using a non PLATFORM-fitted lift truck.
  - Right-hand column
    - With a PLATFORM-fitted lift truck, people can only be lifted using platforms designed by MANITOU for the purpose.
- MANITOU sells equipment specifically designed for lifting people (OPTION PLATFORM lift truck, contact your dealer).

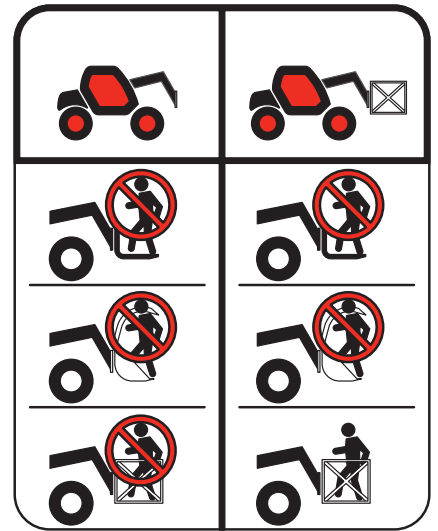

## OPERATING INSTRUCTIONS UNLADEN AND LADEN

### A - BEFORE STARTING THE LIFT TRUCK

- Perform the daily service (see: 3 - MAINTENANCE: A - DAILY OR EVERY 10 HOURS SERVICE).
- Make sure that the driver's cab is clean, particularly the floor and floor mat. Check that no movable object may hinder the operation of the lift truck.
- Make sure the lights, indicators and windscreen wipers are working properly.
- Make sure the rear view mirrors are in good condition, clean and properly adjusted.
- Make sure the horn works.

### B - DRIVER'S OPERATING INSTRUCTIONS

- Whatever his experience, the operator is advised to familiarize himself with the position and operation of all the controls and instruments before operating the lift truck.
- Wear clothes suited for driving the lift truck, avoid loose clothes.
- Make sure you have the appropriate protective equipment for the job to be done.
- Prolonged exposure to high noise levels may cause hearing problems. It is recommended to wear ear muffs to protect against excessive noise.
- Always face the lift truck when getting into and leaving the driving seat and use the handle(s) provided for this purpose. Do not jump out of the seat to get down.
- Always pay attention when using the lift truck. Do not listen to the radio or music using headphones or earphones.
- Never operate the lift truck when hands or feet are wet or soiled with greasy substances.
- For increased comfort, adjust the seat to your requirements and adopt the correct position in the driver's cab.



*Under no circumstances must the seat be adjusted while the lift truck is moving.*

- The operator must always be in his normal position in the driver's cab. It is prohibited to have arms or legs, or generally any part of the body, protruding from the driver's cab of the lift truck.
- The safety belt must be worn and adjusted to the operator's size.
- The control units must never in any event be used for any other than their intended purposes (e.g. climbing onto or down from the lift truck, portmanteau, etc.).
- If the control components are fitted with a forced operation (lever lock) device, it is forbidden to leave the cab without first putting these controls in neutral.
- It is prohibited to carry passengers either on the lift truck or in the cab.

### C - ENVIRONMENT

- Comply with site safety regulations.
- If you have to use the lift truck in a dark area or at night, make sure it is equipped with working lights.
- During handling operations, make sure that no one is in the way of the lift truck and its load.
- Do not allow anybody to come near the working area of the lift truck or pass beneath an elevated load.
- When using the lift truck on a transverse slope, before lifting the boom, follow the instructions given in the paragraph: INSTRUCTIONS FOR HANDLING A LOAD: D - TRANSVERSE ATTITUDE OF THE LIFT TRUCK.

- Travelling on a longitudinal slope:
  - Drive and brake gently.

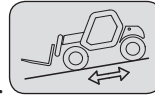

- Moving without load: Forks or attachment facing downhill.

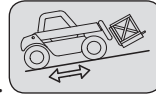

- Moving with load: Forks or attachment facing uphill.

- Take into account the lift truck's dimensions and its load before trying to negotiate a narrow or low passageway.
- Never move onto a loading platform without having first checked:
  - That it is suitably positioned and made fast.
  - That the unit to which it is connected (wagon, lorry, etc.) will not shift.
  - That this platform is prescribed for the total weight of the lift truck to be loaded.
  - That this platform is prescribed for the size of the lift truck.
- Never move onto a foot bridge, floor or freight lift, without being certain that they are prescribed for the weight and size of the lift truck to be loaded and without having checked that they are in sound working order.
- Be careful in the area of loading bays, trenches, scaffolding, soft ground and manholes.
- Make sure the ground is stable and firm under the wheels and/or stabilizers before lifting or removing the load. If necessary, add sufficient wedging under the stabilizers.
- Make sure that the scaffolding, loading platform, pilings or ground is capable of bearing the load.
- Never stack loads on uneven ground, they may tip over.

**⚠ IMPORTANT ⚠**

*If the load or the attachment must remain above a structure for a prolonged period of time, there is the risk that it will bear on the structure as the boom descends due to cooling of the oil in the cylinders.*

*To eliminate this risk:*

*- Regularly check the distance between the load or the attachment and the structure and readjust this if necessary.*

*- If possible use the lift truck at an oil temperature as close as possible to ambient temperature.*

- When working near aerial lines, ensure that the safety distance is sufficient between the working area of the lift truck and the aerial line.

**⚠ IMPORTANT ⚠**

*You must consult your local electrical agency.*

*You could be electrocuted or seriously injured if you operate or park the lift truck too close to power cables.*

*In the event of high winds, do not carry out handling work that jeopardises the stability of the lift truck and its load, particularly if the load catches the wind badly.*

## D - VISIBILITY

- The safety of people within the lift truck's working area, as well as that of the lift truck itself and the operator are depend on good operator visibility of the lift truck's immediate vicinity in all situations and at all times.
- This lift truck has been designed to allow good operator visibility (direct or indirect by means of rear-view mirrors) of the immediate vicinity of the lift truck while travelling with no load and with the boom in the transport position.
- Special precautions must be taken if the size of the load restricts visibility towards the front:
  - moving in reverse,
  - site layout,
  - assisted by a person directing the manoeuvre (while standing outside the truck's area of travel), making sure to keep this person clearly in view at all times,
  - in any case, avoid reversing over long distances.
- Certain special accessories may require the truck to travel with the boom in the raised position. In such cases, visibility on the right hand side is restricted, and special precautions must be taken:
  - site layout,
  - assisted by a person directing the manoeuvre (while standing outside the truck's area of travel).
  - replacement of a suspended load by a load on a pallet.
- If visibility of your road is inadequate, ask someone to assist by directing the manoeuvre (while standing outside the truck's area of travel), making sure to keep this person clearly in view at all times.
- Keep all components affecting visibility in a clean, properly adjusted state and in good working order (e.g. windscreens, windows, windscreen wipers, windscreen washers, driving and work lights, rear-view mirrors).

## E - STARTING THE LIFT TRUCK

### SAFETY INSTRUCTIONS

#### **⚠ IMPORTANT ⚠**

*The lift truck must only be started up or manoeuvred when the operator is sitting in the driver's cab, with his seat belt adjusted and fastened.*

- Never try to start the lift truck by pushing or towing it. Such operation may cause severe damage to the transmission. If necessary, to tow the lift truck in an emergency, the transmission must be placed in the neutral position (see: 3 - MAINTENANCE: G - OCCASIONAL MAINTENANCE).
- If using an emergency battery for start-up, use a battery with the same characteristics and respect battery polarity when connecting it. Connect at first the positive terminals before the negative terminals.

#### **⚠ IMPORTANT ⚠**

*Failure to respect polarity between batteries can cause serious damage to the electrical circuit.*

*The electrolyte in the battery may produce an explosive gas. Avoid flames and generation of sparks close to the batteries.*

*Never disconnect a battery while it is charging.*

### INSTRUCTIONS

- Check the closing and locking of the hood(s).
- Check that the cab door is closed.
- Check that the forward/reverse selector is in neutral, and that the parking brake is applied.
- Press on the service brake pedal and maintain it down.
- Turn the ignition key to the position I to activate the electrical and pre-heating system.
- Whenever you switch on the lift truck, perform the automatic check on the longitudinal stability limiter and warning device (see: 2 - DESCRIPTION: INSTRUMENTS AND CONTROLS). Do not use the lift truck if it does not conform to the regulations.
- Check the fuel level on the indicator.
- Turn the ignition key fully, the engine should then start. Release the ignition key and let the engine run at idle.
- Do not engage the starter motor for more than 15 seconds and carry out the preheating between unsuccessful attempts.
- Make sure all the signal lights on the control instrument panel are off.
- Check all control instruments when the engine is warm and at regular intervals during use, so as to quickly detect any faults and to be able to correct them without any delay.
- If an instrument does not show the correct display, stop the engine and immediately carry out the necessary operations.

## F - DRIVING THE LIFT TRUCK

### SAFETY INSTRUCTIONS

#### **⚠ IMPORTANT ⚠**

*The operators' attention is drawn to the risks involved in using the lift truck, in particular:*

*- Risk of losing control.*

*- Risk of losing lateral and frontal stability of the lift truck.*

*The operator must remain in control of the lift truck.*

*In the event of the lift truck overturning, do not try to leave the cabin during the incident.*

**YOUR BEST PROTECTION IS TO STAY FASTENED IN THE CABIN.**

- Observe the company's traffic regulations or, by default, the public highway code.
- Do not carry out operations which exceed the capacities of your lift truck or attachments.
- Always drive the lift truck with the forks or attachment to the transport position, i.e. at 300 mm from the ground, the boom retracted and the carriage sloping backwards.
- Only carry loads which are balanced and properly anchored to avoid any risk of a load falling off.
- Ensure that palettes, cases, etc, are in good order and suitable for the load to be lifted.
- Familiarise yourself with the lift truck on the terrain where it will be used.
- Ensure that the service brakes are working properly.
- The loaded lift truck must not travel at speeds in excess of 12 km/h.
- Drive smoothly at an appropriate speed for the operating conditions (land configuration, load on the lift truck).
- Do not use the hydraulic boom controls when the lift truck is moving.
- Never change the steering mode whilst driving.
- Do not manoeuvre the lift truck with the boom in the raised position unless under exceptional circumstances and then with extreme caution, at very low speed and using gentle braking. Ensure that visibility is adequate.
- Take bends slowly.
- In all circumstances make sure you are in control of your speed.
- On damp, slippery or uneven terrain, drive slowly.
- Brake gently, never abruptly.
- Only use the lift truck's forward/reverse selector from a stationary position and never do so abruptly.
- Do not drive with your foot on the brake pedal.
- Always remember that hydrostatic type steering is extremely sensitive to movement of the steering wheel, so turn it gently and not jerkily.
- Never leave the engine on when the lift truck is unattended.

- Do not leave the cab when the lift truck has a raised load.
- Look where you are going and always make sure you have good visibility along the route.
- Use the rear-view mirrors frequently.
- Drive round obstacles.
- Never drive on the edge of a ditch or steep slope.
- It is dangerous to use two lift trucks simultaneously to handle heavy or bulky loads, since this operation requires particular precautions to be taken. It must only be used exceptionally and after risk analysis.
- The ignition switch has an emergency stop mechanism in case of an operating anomaly occurring in the case of lift trucks not fitted with a punch-operated cut-out.

## INSTRUCTIONS

- Always drive the lift truck with the forks or attachment to the transport position, i.e. at 300 mm from the ground, the boom retracted and the carriage sloping backwards.
- For lift trucks with gearboxes, use the recommended gear (see: 2 - DESCRIPTION: INSTRUMENTS AND CONTROLS).
- Select the steering mode appropriate for its use and/or working conditions (see: 2 - DESCRIPTION: INSTRUMENTS AND CONTROLS) (as model of lift truck).
- Release the hand brake.
- Shift the forward/reverse selector to the selected direction of travel and accelerate gradually until the lift truck moves off.

### **⚠ IMPORTANT ⚠**

*Starting and driving a lift truck on a slope can present a very real danger.  
The lift truck being parked or stopped, scrupulously follow the following instructions for moving off:*

- *Press the service brake pedal.*
- *Engage 1st or 2nd gear and select forward or reverse.*
- *Check that there is nothing and no-one obstructing the lift truck's path.*
- *Release the service brake pedal and increase the engine revs.*

*The risk is increased if the lift truck is laden or towing a trailer, requiring extreme vigilance.*

## **G - STOPPING THE LIFT TRUCK**

### SAFETY INSTRUCTIONS

- Never leave the ignition key in the lift truck during the operator's absence.
- When the lift truck is stationary, or if the operator has to leave his cab (even for a moment), place the forks or attachment on the ground, apply the parking brake and place the forward/reverse selector in neutral.
- Make sure that the lift truck is not stopped in any position that will interfere with the traffic flow and at less than one meter from the track of a railway.
- In the event of prolonged parking on a site, protect the lift truck from bad weather, particularly from frost (check the level of antifreeze), close and lock all the lift truck accesses (doors, windows, cowls, etc.).

### INSTRUCTIONS

- Park the lift truck on flat ground or on an incline lower than 15 %.
- Set the forward/reverse selector to neutral.
- Engage the parking brake.
- For lift trucks with gearboxes, place the gear lever in neutral.
- Fully retract the boom.
- Lower the forks or attachment to rest on the ground.
- When using an attachment with a grab or jaws, or a bucket with hydraulic opening, close the attachment fully.
- Before stopping the lift truck after a long working period, leave the engine idling for a few moments, to allow the coolant liquid and oil to lower the temperature of the engine and transmission. Do not forget this precaution, in the event of frequent stops or warm stalling of the engine, or else the temperature of certain parts will rise significantly due to the stopping of the cooling system, with the risk of badly damaging such parts.
- Stop the engine with the ignition switch.
- Remove the ignition key.
- Lock all the accesses to the lift truck (doors, windows, cowls...).



## H - DRIVING THE LIFT TRUCK ON THE PUBLIC HIGHWAY

(or see current legislation in other countries)

### FRENCH ROAD TRAFFIC RULES

- The driving of non EC type-approved tractors on the public highway is subject to the provisions of the highway code relating to special machines, defined in article R311-1 of the highway code, in category B of the Equipment Order of 20 November 1969 that determines the procedures applicable to special machines. The lift truck must be fitted with a licence plate.
- The driving of EC type-approved tractors on the public highway is subject to the provisions of the highway code regarding agricultural tractors, defined in article R311-1 of the highway code. The lift truck must be registered.
- The lift truck must be driven on the public highway in accordance with the instructions given in the manual supplied with the lift truck (Gross weight, Gross combination weight, towing load, axle loads, maximum speeds, etc. according to type/version). The operator must be in possession of the lift truck's registration document.
- The operator must hold an HGV licence, unless granted an exemption.
- When towing a trailer or agricultural equipment, the travelling speed of the lift truck is limited to 25 km/h. In this case, a "25" disc must be affixed to the rear of the convoy. When driving with a trailer, the fact of not engaging 4th gear will ensure compliance with the towing speed limit (max. 25 km/h). On "POWERSHIFT" models, as 3rd gear is slower than on other models, it is preferable to use 5th gear and disable automatic upshifting to 6th gear (see: 2 - DESCRIPTION: INSTRUMENTS AND CONTROLS).

### SAFETY INSTRUCTIONS

- Operators driving on the public highway must comply with current highway code legislation.
- The lift truck must comply with current road legislation. If necessary, there are optional solutions. Contact your dealer.

### INSTRUCTIONS

- Make sure the revolving light is in place, switch it on and verify its operation.
- Make sure the lights, indicators and windscreen wipers are working properly.
- Switch off the working headlights if the lift truck is fitted with them.
- Select the steering mode "HIGHWAY TRAFFIC" (as model of lift truck) (see: 2 - DESCRIPTION: INSTRUMENTS AND CONTROLS).
- Fully retract the boom and set the attachment approximately 300 mm off the ground.
- Place the roll corrector in the central position, i.e. the transverse axis of the axles parallel to the chassis (as model of lift truck).
- Fully raise the stabilizers and turn the blocks inwards (according to model of lift truck).

#### **⚠ IMPORTANT ⚠**

***Never coast in neutral (forward/reverse selector or gear lever in neutral or transmission cut-off button pressed) to preserve the lift truck engine brake. Failure to observe this instruction on a slope will lead to excessive speed which may make the lift truck uncontrollable (steering, brakes) and cause serious mechanical damage.***

### DRIVING THE LIFT TRUCK WITH A FRONT-MOUNTED ATTACHMENT

- You must comply with current regulations in your country, covering the possibility of driving on the public highway with a front-mounted attachment on your lift truck.
- If road legislation in your country authorizes circulation with a front-mounted attachment, you must at least:
  - Protect and report any sharp and/or dangerous edges on the attachment (see: 4 - ADAPTABLE ATTACHMENTS IN OPTION ON THE RANGE: ATTACHMENT SHIELDS).
  - The attachment must not be loaded.
  - Make sure that the attachment does not mask the lighting range of the forward lights.
  - Make sure that current legislation in your country does not require other obligations.

### OPERATING THE LIFT TRUCK WITH A TRAILER

- For using a trailer, observe the regulations in force in your country (maximum travel speed, braking, maximum weight of trailer, etc.).
- Do not forget to connect the trailer's electrical equipment to that of the lift truck.
- The trailer's braking system must comply with current legislation.
- If pulling a trailer with assisted braking, the tractor lift truck must be equipped with a trailer braking mechanism. In this case, do not forget to connect the trailer braking equipment to the lift truck.
- The vertical force on the towing hook must not exceed the maximum authorised by the manufacturer (consult the manufacturer's plate on your lift truck).
- The authorised gross vehicle weight must not exceed the maximum weight authorised by the manufacturer (see: 2 - DESCRIPTION: CHARACTERISTICS).

**IF NECESSARY, CONSULT YOUR DEALER.**

### A - CHOICE OF ATTACHMENTS

- Only attachments approved by MANITOU can be used on its lift trucks.
- Make sure the attachment is appropriate for the work to be done (see: 4 - ADAPTABLE ATTACHMENTS IN OPTION ON THE RANGE).
- If the lift truck is equipped with the Single side-shift carriage OPTION (TSDL), use only the authorised attachments (see: 4 - ADAPTABLE ATTACHMENTS IN OPTION ON THE RANGE).
- Make sure the attachment is correctly installed and locked onto the lift truck carriage.
- Make sure that your lift truck attachments work properly.
- Comply with the load chart limits for the lift truck for the attachment used.
- Do not exceed the rated capacity of the attachment.
- Never lift a load in a sling without the attachment provided for the purpose, as the sling risks to slip (see: INSTRUCTIONS FOR HANDLING A LOAD: H - TAKING UP AND LAYING DOWN A SUSPENDED LOAD).
- Do not handle loads that are hung directly from the forks with straps (e.g.: big-bag), as there is a risk that the straps will shear against the sharp edges. Use an attachment designed for this purpose.

### B - MASS OF LOAD AND CENTRE OF GRAVITY

- Before taking up a load, you must know its mass and its centre of gravity.
- The load chart for your lift truck is valid for a load in which the longitudinal position of the centre of gravity is 500 mm from the base of the forks (fig. B1). For a higher centre of gravity, contact your dealer.
- For irregular loads, determine the transverse centre of gravity before any movement (fig. B2) and set it in the longitudinal axis of the lift truck.

#### ⚠ IMPORTANT ⚠

*It is forbidden to move a load heavier than the effective capacity defined on the lift truck load chart.  
For loads with a moving centre of gravity (e.g. liquids), take account of the variations in the centre of gravity in order to determine the load to be handled and be vigilant and take extra care to limit these variations as far as possible.*

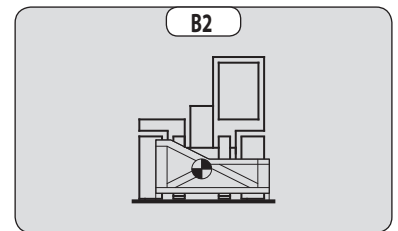
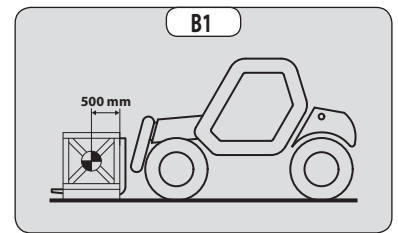

### C - LONGITUDINAL STABILITY LIMITER AND WARNING DEVICE

This device gives an indication of the longitudinal stability of the lift truck, and limits hydraulic movements in order to ensure this stability, at least under the following operating conditions:

- when the lift truck is at a standstill,
  - when the lift truck is on firm, stable and consolidated ground,
  - when the lift truck is performing handling and placing operations.
- Move the jib very carefully when approaching the authorized load limit (see: 2 - DESCRIPTION: INSTRUMENTS AND CONTROLS).
  - Always watch this device during handling operations.
  - In the event that "AGGRAVATING" hydraulic movements are cut-off, only perform de-aggravating hydraulic movements in the following order (fig. C): if necessary, raise the jib (1), retract the jib as far as possible (2) and lower the jib (3) to set down the load.

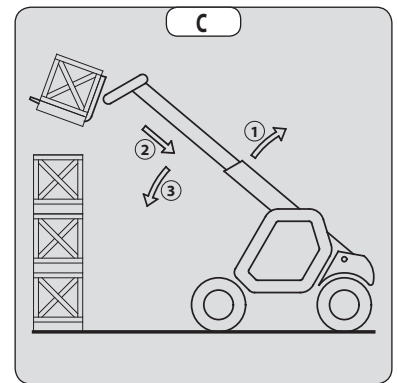

#### ⚠ IMPORTANT ⚠

*The instrument reading may be erroneous when the steering is at full lock or the rear axle is oscillated to its maximum extent.  
Before lifting a load, make sure that the lift truck is not in either of these situations.*

## D - TRANSVERSE ATTITUDE OF THE LIFT TRUCK

Depending on the model of lift truck

The transverse attitude is the transverse slope of the chassis with respect to the horizontal.

Raising the jib reduces the lift truck's lateral stability. The transverse attitude must be set with the jib in down position as follows:

### 1 - LIFT TRUCK WITHOUT ROLL CORRECTOR USED ON TYRES

- Position the lift truck so that the bubble in the level is between the two lines (see: 2 - DESCRIPTION: INSTRUMENTS AND CONTROLS).

### 2 - LIFT TRUCK WITH ROLL CORRECTOR USED ON TYRES

- Correct the roll using the hydraulic control and check horizontality with the spirit level. The bubble in the level must be between the two lines (see: 2 - DESCRIPTION: INSTRUMENTS AND CONTROLS).

### 3 - LIFT TRUCK USED ON STABILIZERS

- Set the two stabilizers on the ground and raise the two front wheels of the lift truck (fig. D1).
- Correct the roll using the stabilizers (fig. D2) and check horizontality with the spirit level. The bubble of the level must be between the two lines (see: 2 - DESCRIPTION: INSTRUMENTS AND CONTROLS). In this position, the two front wheels must be off the ground.

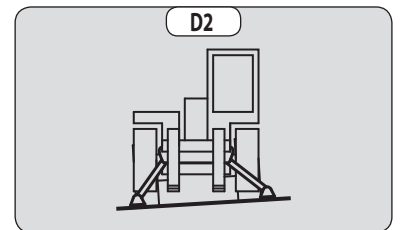
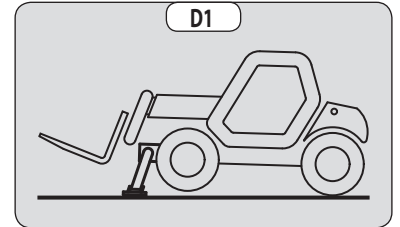

## E - TAKING UP A LOAD ON THE GROUND

- Approach the lift truck perpendicular to the load, with the jib retracted and the forks in a horizontal position (fig. E1).
- Adjust the fork spread and centring relative to the load to ensure stability (fig. E2) (optional solutions exist, consult your dealer).
- Never lift a load with a single fork.

**⚠ IMPORTANT ⚠**

*Beware of the risks of trapping or squashing limbs when manually adjusting the forks.*

- Move the lift truck forward slowly (1) and insert the forks under the load as far as they will go (fig. E3). If necessary, slightly lift the jib (2) while taking up the load.
- Bring the load into the transport position.
- Tilt the load far enough backwards to ensure stability (loss of load on braking or going downhill).

### FOR A NON-PALLETISED LOAD

- Tilt the carriage (1) forwards and move the lift truck slowly forwards (2), to insert the fork under the load (fig. E4) (block the load if necessary).
- Continue to move the lift truck forwards (2) tilting the carriage (3) (fig. E4) backwards to position the load on the forks and check the load's longitudinal and lateral stability.

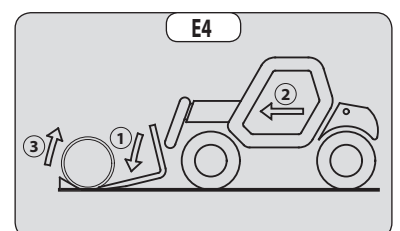
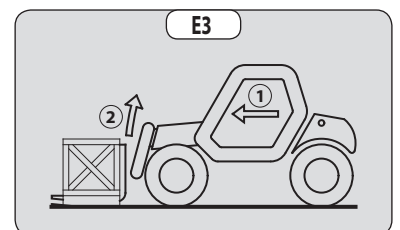
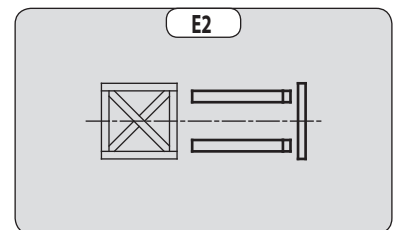
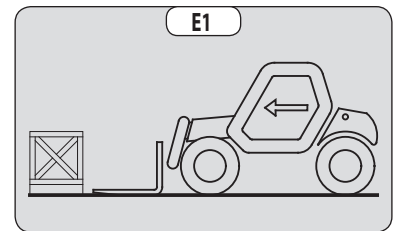

## F - TAKING UP AND LAYING A HIGH LOAD ON TYRES

### ⚠ IMPORTANT ⚠

*You must not raise the jib if you have not checked the transverse attitude of the lift truck (see: INSTRUCTIONS FOR HANDLING A LOAD: D - TRANSVERSE ATTITUDE OF THE LIFT TRUCK).*

REMINDER: Make sure that the following operations can be performed with good visibility (see: OPERATIONS INSTRUCTIONS UNLADEN AND LADEN: D - VISIBILITY).

### TAKING UP A HIGH LOAD ON TYRES

- Ensure that the forks will easily pass under the load.
- Lift and extend the jib (1) (2) until the forks are level with the load, moving the lift truck (3) forward if necessary (fig. F1), moving very slowly and carefully.
- Always remember to keep the distance necessary for inserting the forks under the load, between the stack and the lift truck (fig. F1) and use the shortest possible length of jib.
- Insert the forks under the load as far as they will go by alternately extending and lowering the jib (1) or, if necessary, moving the lift truck forward (2) (fig. F2). Apply the handbrake and place the forward/reverse selector in neutral.
- Slightly raise the load (1) and tilt the carriage (2) backwards to stabilize the load (fig. F3).
- Tilt the load sufficiently backwards to ensure its stability.
- Monitor the longitudinal stability limiter and warning device (see: INSTRUCTIONS FOR HANDLING A LOAD: C - LONGITUDINAL STABILITY LIMITER AND WARNING DEVICE). If it is overloaded, set the load back down in the place from which it was taken.
- If possible lower the load without shifting the lift truck. Lift the jib (1) to release the load, retract (2) and lower the jib (3) to bring the load into the transport position (fig. F4).
- If this is not possible, back up the lift truck (1), manoeuvring very gently and carefully to release the load. Retract (2) and lower the jib (3) to bring the load into the transport position (fig. F5).

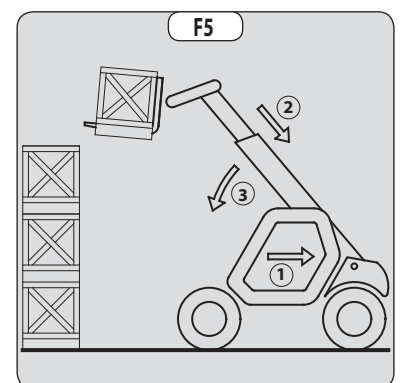
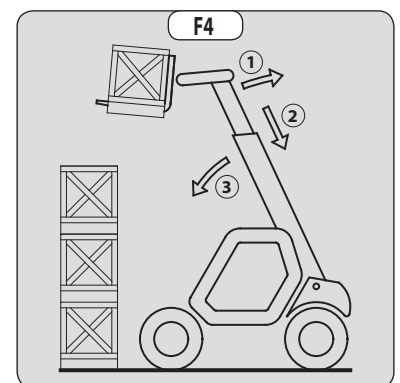
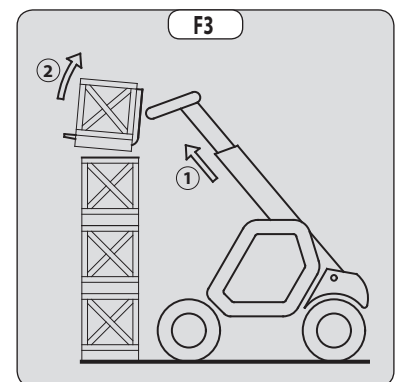
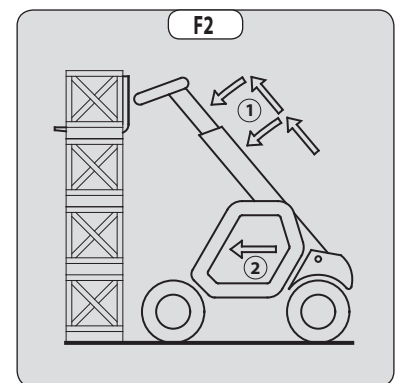
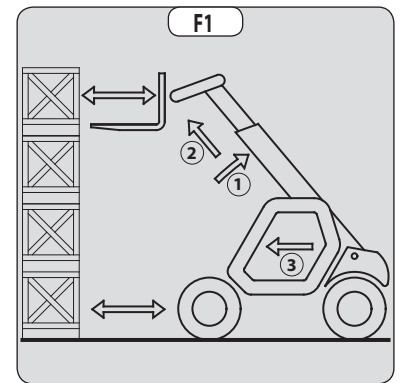

## LAYING A HIGH LOAD ON TYRES

- Approach the load in the transport position in front of the stack (fig. F6).
- Apply the parking brake and place the forward/reverse selector in neutral.
- Raise and extend the jib (1) (2) until the load is above the stack, while monitoring the longitudinal stability limiter and warning device (see: INSTRUCTIONS FOR HANDLING A LOAD: C - LONGITUDINAL STABILITY LIMITER AND WARNING DEVICE). If necessary, move the lift truck (3) forward (fig. F7), driving very slowly and carefully.
- Place the load in a horizontal position and lay it down on the pile by lowering and retracting the jib (1) (2) in order to position the load correctly (fig. F8).
- If possible, release the fork by alternately retracting and raising the jib (1) (fig. F9). Then set the forks into transport position.
- If this is not possible, reverse the lift truck (1) very slowly and carefully to release the forks (fig. F10). Then set them into transport position.

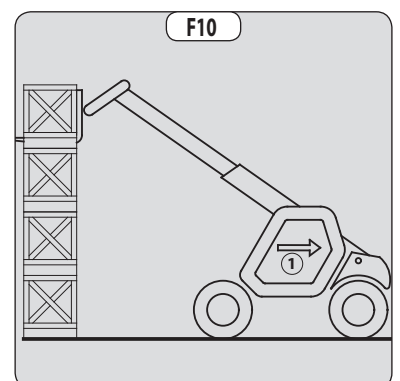
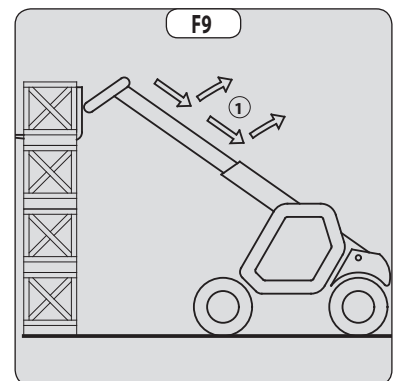
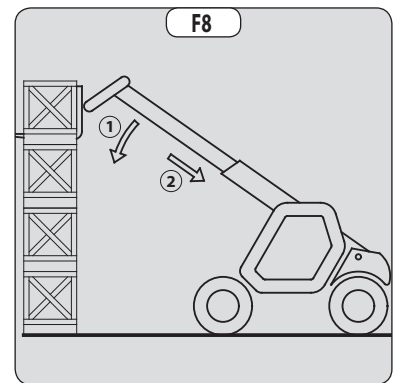
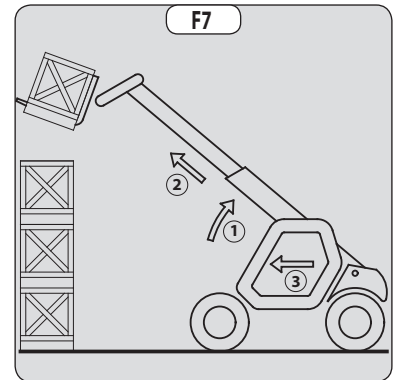
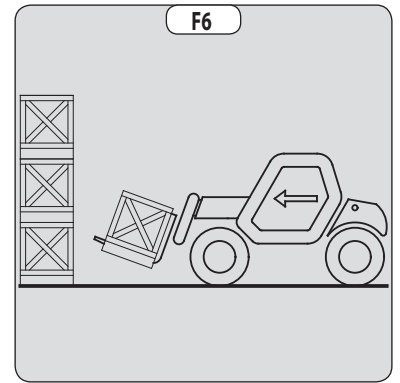

## G - TAKING UP AND LAYING A HIGH LOAD ON STABILIZERS

Depending on the model of lift truck

### ⚠ IMPORTANT ⚠

*You must not raise the jib if you have not checked the transverse attitude of the lift truck (see: INSTRUCTIONS FOR HANDLING A LOAD: D - TRANSVERSE ATTITUDE OF THE LIFT TRUCK).*

REMINDER: Make sure that the following operations can be performed with good visibility (see: OPERATIONS INSTRUCTIONS UNLADEN AND LADEN: D - VISIBILITY).

The stabilizers are used to optimise the lift truck's lifting performances (see: 2 - DESCRIPTION: INSTRUMENTS AND CONTROLS).

POSITION THE STABILIZERS WITH THE FORKS IN TRANSPORT POSITION (UNLADEN AND LADEN)

- Set the forks in transport position in front of the elevation.
- Stay far enough away to have room for the jib to be raised.
- Apply the parking brake and place the forward/reverse selector in neutral.
- Set the two stabilizers on the ground and lift the two front wheels of the lift truck (fig. G1), while maintaining its transverse stability.

RAISE THE STABILIZERS WITH THE FORKS IN TRANSPORT POSITION (UNLADEN AND LADEN)

- Raise both stabilizers fully and at the same time.

LOWERING OF STABILISERS WITH JIB UP (UNLADEN AND LADEN).

### ⚠ IMPORTANT ⚠

*This operation must be exceptional and performed with great care.*

- Raise the jib and retract the telescopes completely.
- Set the lift truck in position in front of the elevation (fig. G2) moving very slowly and carefully.
- Apply the parking brake and place the forward/reverse selector in neutral.
- Move the stabilizers very slowly and gradually as soon as they are close to the ground or in contact with it.
- Lower the two stabilizers and lift the two front wheels of the lift truck (fig. G3). During this operation, transverse attitude must be permanently maintained: the bubble in the level must be kept between the two lines.

SETTING THE STABILIZERS WITH THE JIB UP (UNLADEN AND LADEN)

### ⚠ IMPORTANT ⚠

*This operation must be exceptional and performed with great care.*

- Keep the jib up and retract the telescopes completely (fig. G3).
- Move the stabilizers very slowly and gradually as soon as they are in contact with the ground and when they leave the ground. During this operation, the transverse attitude must be permanently maintained: the bubble in the level must be kept between the two lines.
- Raise both stabilizers completely.
- Release the parking brake and reverse the lift truck (1) very slowly and carefully, to release it and lower the forks (2) into transport position (fig. G4).

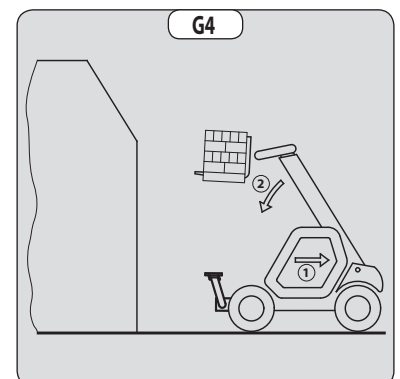
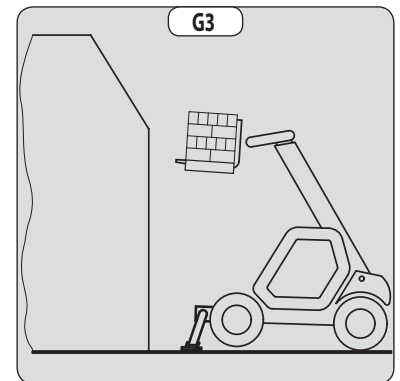
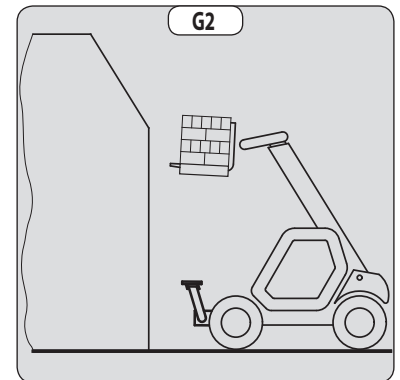
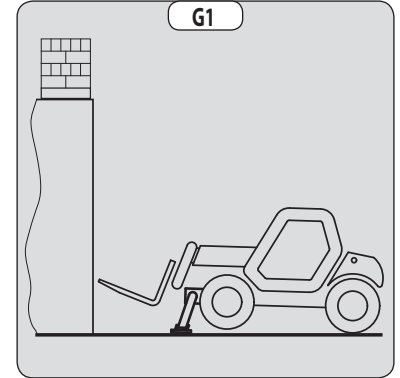

## TAKING UP A HIGH LOAD ON STABILISERS

- Ensure that the forks will easily pass under the load.
- Check the position of the lift truck with respect to the load and make a test run, if necessary, without taking the load.
- Raise and extend the jib (1) (2) until the forks are at the level of the load (fig. G5).
- Insert the forks under the load as far as they will go by alternately extending and lowering the jib (1) (fig. G6).
- Lift the load slightly (1) and tilt the carriage (2) backwards to stabilise the load (fig. G7).
- Monitor the longitudinal stability limiter and warning device (see: INSTRUCTIONS FOR HANDLING A LOAD: C - LONGITUDINAL STABILITY LIMITER AND WARNING DEVICE). If it is overloaded, set the load back down in the place from which it was taken.
- If possible lower the load without moving the lift truck. Raise the jib (1) to release the load, retract (2) and lower the jib (3) to set the load into transport position (fig. G8).

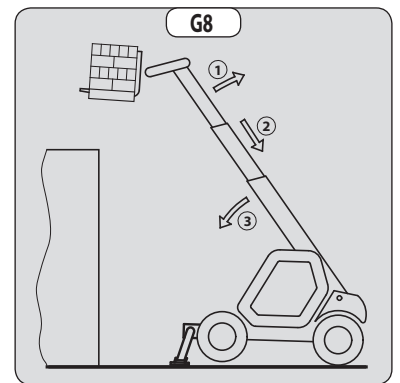
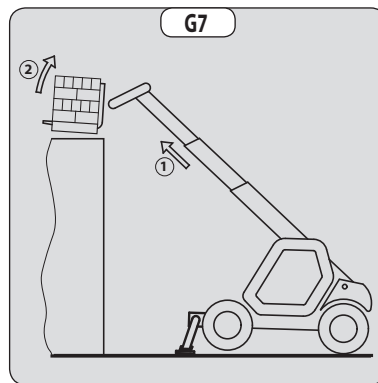
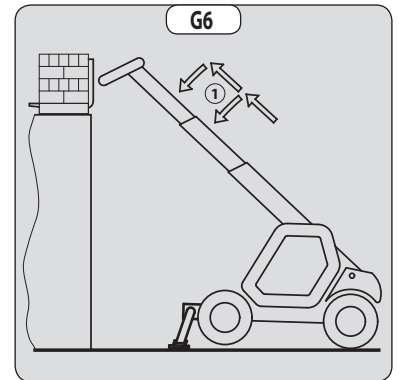
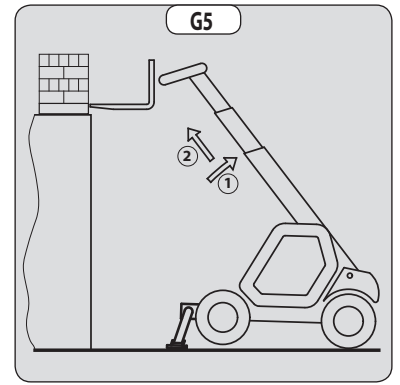

## LAYING A HIGH LOAD ON STABILISERS

- Raise and extend the jib (1) (2) until the load is above the elevation (fig. G9), while monitoring the longitudinal stability limiter and warning device (see: INSTRUCTIONS FOR HANDLING A LOAD: C - LONGITUDINAL STABILITY LIMITER AND WARNING DEVICE).
- Position the load horizontally and release it by lowering and retracting the jib (1) (2) to position the load correctly (fig. G10).
- Free the forks by alternating retracting and raising the jib (3) (fig. G11).
- If possible, set the jib in transport position without moving the lift truck.

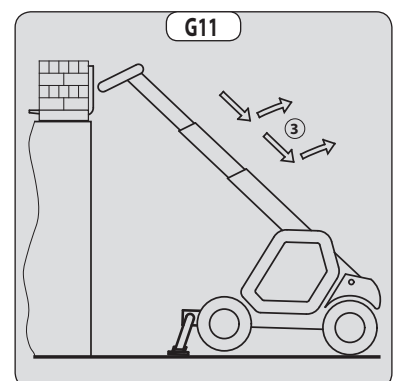
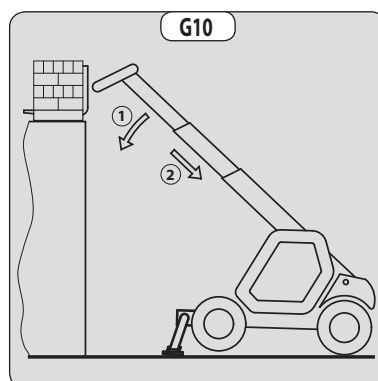
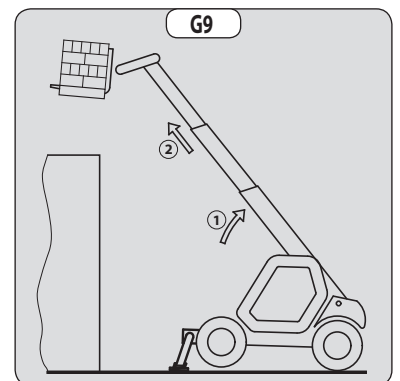

## H - TAKING UP AND LAYING DOWN A SUSPENDED LOAD

### **⚠ IMPORTANT ⚠**

*Failure to follow the above instructions may lead the lift truck to loose stability and overturn.  
MUST be used with a lift truck equipped with an operational hydraulic movement cut-out device.*

#### CONDITIONS OF USE

- The length of the sling or the chain shall be as short as possible to limit swinging of the load.
- Lift the load vertically along its axis, never by pulling sideways or lengthways.

#### HANDLING WITHOUT MOVING THE LIFT TRUCK

- Whether on stabilisers or on tyres, the lateral attitude must not exceed 1 % and the longitudinal attitude must not exceed 5%, the bubble of the level must be held at "0".
- Ensure that the wind speed is not higher than 10 m/s.
- Ensure that there is no one between the load and the lift truck.

#### I - TRAVELLING WITH A SUSPENDED LOAD

- Before moving, inspect the terrain in order to avoid excessive slopes and cross-falls, bumps and potholes, or soft ground.
- Ensure that the wind speed is not higher than 36 km/h.
- The lift truck must not travel at more than 0,4 m/s (1,5 km/h, i.e., one quarter walking speed).
- Drive and stop the lift truck gently and smoothly to minimise swinging of the load.
- Carry the load a few centimetres above the ground (max. 30 cm) the shortest possible jib length. Do not exceed the offset indicated on the load chart. If the load begins to swing excessively, do not hesitate to stop and lower the jib to set down the load.
- Before moving the lift truck, check the longitudinal stability limiter and warning device (see: 2 - DESCRIPTION: INSTRUMENTS AND CONTROLS), only the green LEDs and possible the yellow LEDs should be lit.
- During transport, the lift truck operator must be assisted by a person on the ground (standing a minimum of 3 m from the load), who will limit swinging of the load using a bar or a rope. Ensure that this person is always clearly in view.
- The lateral attitude must not exceed 5 %, the bubble in the level must be kept between the two "MAX" marks
- The longitudinal attitude must not exceed 15 %, with the load facing uphill, and 10%, with the load facing downhill.
- The jib angle must not exceed 45°.
- If the first red LED of longitudinal stability limiter and warning device (see: 2 - DESCRIPTION: INSTRUMENTS AND CONTROLS) comes on while travelling, gently bring the lift truck to a halt and stabilise the load. Retract the telescope to reduce the offset of the load.



## PLATFORM OPERATING INSTRUCTIONS

For lift trucks fitted with a PLATFORM

### A - AUTHORISATION FOR USE

- Operation of the platform requires further authorisation in addition to that of the lift truck.

### B - LIFT TRUCK SUITABILITY FOR USE

- MANITOU has ensured that this platform is suitable for use under the normal operating conditions defined in this operator's manual, with a **STATIC** test coefficient **OF 1,25** and a **DYNAMIC** test coefficient **OF 1,1**, as specified in harmonised standard **EN 280** for "mobile elevating work platforms".
- Before commissioning, the company manager must make sure that platform is appropriate for the work to be done, and perform certain tests (in accordance with current legislation).

### C - PRECAUTIONS WHEN USING THE PLATFORM

- Wear suitable clothing when using the platform, avoid loosely-fitting garments.
- Never operate the platform when hands or feet are wet or soiled with greasy substances.
- Remain alert at all times when using the platform. Do not listen to the radio or music using headphones or earphones.
- For increased comfort, adopt the correct position at the platform's operator station.
- The platform's guard rail exempts the operator from wearing a safety harness under normal operating conditions. As a result, you are responsible for deciding whether to wear a safety harness.
- The control units must never in any event be used for any other than their intended purposes (e.g. climbing onto or down from the lift truck, portmanteau, etc.).
- Safety helmets must be worn.
- The operator must always be in the normal operator's position. It is prohibited to have arms or legs, or generally any part of the body, protruding from the basket.
- Ensure that any materials loaded onto the platform (pipes, cables, containers, etc.) cannot fall out. Do not pile these materials to the point where it is necessary to step over them.

### D - USING THE PLATFORM

- However experienced they may be, operators must acquaint themselves with the emplacement and operation of all control instruments prior to operating the platform.
- Check before use that the platform has been correctly assembled and locked onto the lift truck.
- Check before operating the platform that the access gate has been properly locked.
- The platform should be operated in an area free of any obstructions or danger when it is lowered to the ground.
- The operator using the platform must be aided on the ground by a person with adequate training.
- You should stay within the limits set out in the platform load chart.
- The lateral stresses are limited pressure (see: 2 - DESCRIPTION: CHARACTERISTICS).
- It is strictly forbidden to hang a load from the platform or the lift truck jib without a specially designed attachment (see: INSTRUCTIONS FOR HANDLING A LOAD: H - TAKING UP AND LAYING DOWN A SUSPENDED LOAD).
- The platform cannot be used as a crane or a lift for permanently transporting people or materials, nor as jacks or supports.
- The lift truck must not be moved with one (or more) person(s) in the platform.
- It is forbidden to transport people on the platform using the hydraulic controls in the lift truck's driver's cab (except in case of rescue).
- The operator must not climb onto to off the platform when it is not on ground level (jib retracted and in the down position).
- The platform must not be fitted with attachments that increase the unit's wind load.
- Do not use ladders or improvised structures in the platform to gain extra height.
- Do not climb onto the sides of the platform to gain extra height.
- It is forbidden to use the platform on forks. The fork slots are only to, be used for storing the platform and not for lifting people under any circumstances.

### E - ENVIRONMENT



*It is forbidden to use the platform close to electricity cables. Maintain the specified safe distances.*

RATED VOLTAGE	SAFE DISTANCE (METRES)
50 < U < 1000	2,30 M
1000 < U < 30000	2,50 M
30000 < U < 45000	2,60 M
45000 < U < 63000	2,80 M
63000 < U < 90000	3,00 M
90000 < U < 150000	3,40 M
150000 < U < 225000	4,00 M
225000 < U < 400000	5,30 M
400000 < U < 750000	7,90 M

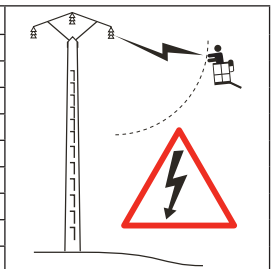

**⚠ IMPORTANT ⚠**

*It is strictly forbidden to use the platform when the wind speed exceeds 45 km/h.*

- To visually recognise this wind speed, refer to the empirical wind evaluation scale below:

BEAUFORT scale (wind speed at a height of 10 m on a flat site)						
Force	Type of wind	Speed (knots)	Speed (km/h)	Speed (m/s)	Effects on Land	Sea conditions
0	Calm	0 - 1	0 - 1	< 0,3	- Smoke rises vertically.	- Sea is like a mirror.
1	Light air	1 - 3	1 - 5	0,3 - 1,5	- Smoke indicates direction of wind.	- Ripples with appearance of scale, no foam crests.
2	Light breeze	4 - 6	6 - 11	1,6 - 3,3	- Wind felt on face, leaves rustle.	- Short wavelets, but pronounced.
3	Gentle breeze	7 - 10	12 - 19	3,4 - 5,4	- Leaves and small twigs in constant motion.	- Very small waves, crests begin to break.
4	Moderate breeze	11 - 16	20 - 28	5,5 - 7,9	- Wind raises dust and loose pieces of paper; small branches are moved.	- Small waves, becoming longer, numerous whitecaps.
5	Fresh breeze	17 - 21	29 - 38	8 - 10,7	- Small trees in leaf begin to sway.	- Wavelets form on inland waters; moderate waves, taking longer form.
6	Strong breeze	22 - 27	39 - 49	10,8 - 13,8	- Large branches in motion, whistling heard in overhead wires, umbrella use becomes difficult.	- Larger waves forming, whitecaps everywhere, some spray.
7	Near gale	28 - 33	50 - 61	13,9 - 17,1	- Whole trees in motion, inconvenience felt when walking against the wind.	- Sea heaps up; white foam from breaking waves begins to be blown in streaks along the direction of the wind.
8	Gale	34 - 40	62 - 74	17,2 - 20,7	- Wind breaks twigs off trees; impedes progress.	- Moderately high waves of greater length; edges of crests begin to break into spindrift.
9	Strong gale	41 - 47	75 - 88	20,8 - 24,4	- Wind damages roofs (chimneys, slates, etc.).	- High waves, crests of waves begin to topple, streaks of foam; reduced visibility.
10	Storm	48 - 55	89 - 102	24,5 - 28,4	- Seldom experienced inland; trees uprooted; considerable structural damage occurs.	- Very high waves; white streaks of foam; reduced visibility.
11	Violent storm	56 - 63	103 - 117	28,5 - 32,6	- Very rare, widespread damage.	- Exceptionally high waves able to hide medium sized ships from view, reduced visibility.
12	Hurricane	64 +	118 +	32,7 +	- Devastating damage.	- Sea completely white; air filled with foam and spray, very reduced visibility.

**F - MAINTENANCE**

**⚠ IMPORTANT ⚠**

*Your platform must be periodically inspected to ensure its continued compliance.  
The inspection frequency is defined by the legislation applying in the country in which the platform is used.  
In France, a general periodic inspection every 6 months (order of 1 March 2004).*

## INSTRUCTIONS FOR USING THE RADIO-CONTROL

For lift trucks with RC radio control

### HOW TO USE THE RADIO-CONTROL

#### SAFETY INSTRUCTIONS

- This radio-control consists of electronic and mechanical safety elements. It cannot receive commands from another transmitter because the internal encoding is unique to each radio-control.

#### **⚠ IMPORTANT ⚠**

*If it is used improperly or incorrectly, there is a risk of danger to:*

- *The physical and mental health of the user or others.*
- *The lift truck and other neighbouring items.*

*All those working with this radio-control:*

- *Must be qualified in line with current regulations and trained accordingly.*
- *Must follow this instruction manual as closely as possible.*

- The system is used to control the lift truck remotely via radio waves. Commands are also transmitted if the lift truck is out of sight (behind an obstacle or a building for example), this is why:
  - After stopping the truck and removing the key switch (only possible when it is stationary), always place the transmitter in a safe, dry place.
  - Before performing any installation, servicing or repair work, always switch off power sources (in particular, electric welding devices and electric head units on hydraulic distributors must be disconnected at each section).
  - Never remove or alter the safety devices (such as the hand-guard frame, key, emergency stop button, etc.).

#### **⚠ IMPORTANT ⚠**

*Never drive the lift truck if it is not continuously and perfectly within view of the operator!*

- Before leaving the transmitter, the operator must make sure that it cannot be used by an unauthorized third person: either by removing the key button from the transmitter or locking it in an inaccessible place.
- The user must ensure that the instruction manual is accessible at all times and that operators have read and understood it.

#### INSTRUCTIONS

- Take up position in a stable place with no risk of slipping.
- Before using the transmitter, make sure there is nobody within the working area.
- Only use the transmitter with its carrying device or installed correctly on the platform.

#### **⚠ IMPORTANT ⚠**

*When you remove the transmitter, remove the accumulator and key button so that it cannot be used accidentally or deliberately by anyone else.*

#### PROTECTIVE DEVICES

- The lift truck will be immobilised within a maximum of 450 milliseconds (approx. 0.5 second):
  - If the emergency stop button of the transmitter is pressed (50 milliseconds), or that of the lift truck.
  - If the transmission distance of the radio waves is exceeded.
  - If the transmitter is faulty.
  - If an interfering radio signal is received from elsewhere.
  - If the accumulator is removed from its housing in the transmitter.
  - If the battery reaches the end of its autonomy.
  - If the transmitter is switched off by turning the key switch to the off position.
- These protective devices are provided for the safety of personnel and property and must never be altered, removed or bypassed in any way whatsoever!
- The hand-guard frame prevents external action on a manipulator (e.g. if the transmitter is dropped, or if the operator leans on a guard-rail).
- An electronic safety device prevents radio transmission from being initiated if the manipulators are not mechanically and electrically at rest and if the internal combustion engine speed selector is not set to idle.

#### **⚠ IMPORTANT ⚠**

*In an emergency, press the transmitter emergency stop button immediately ; then follow the manual's instructions (see: 2 - DESCRIPTION: INSTRUMENTS AND CONTROLS).*

# LIFT TRUCK MAINTENANCE INSTRUCTIONS

## GENERAL INSTRUCTIONS

- Ensure the area is sufficiently ventilated before starting the lift truck.
- Wear clothes suitable for the maintenance of the lift truck, avoid wearing jewellery and loose clothes. Tie and protect your hair, if necessary.
- Stop the engine and remove the ignition key, when an intervention is necessary.
- Read the operator's manual carefully.
- Carry out all repairs immediately, even if the repairs concerned are minor.
- Repair all leaks immediately, even if the leak concerned is minor.
- Make sure that the disposal of process materials and of spare parts is carried out in total safety and in an ecological way.
- Be careful of the risk of burning and splashing (exhaust, radiator, engine, etc.).

## PLACING THE JIB SAFETY WEDGE

- The lift truck is equipped with a jib safety wedge (see: 2 - DESCRIPTION: INSTRUMENTS AND CONTROLS) that must be installed on the rod of the lifting cylinder when working beneath the jib.

### FITTING THE WEDGE

- Fully raise the jib.
- Place the safety wedge 1 on the rod of the lifting cylinder and secure with the rod 2 and the pin 3.
- Slowly lower the jib then stop the hydraulic movements before it comes into contact with the wedge.

### REMOVING THE WEDGE

- Fully raise the jib.
- Remove the pin and the rod.
- Return the safety wedge to the storage location provided on the lift truck.

**⚠ IMPORTANT ⚠**

*Only use the wedge supplied with the lift truck.*

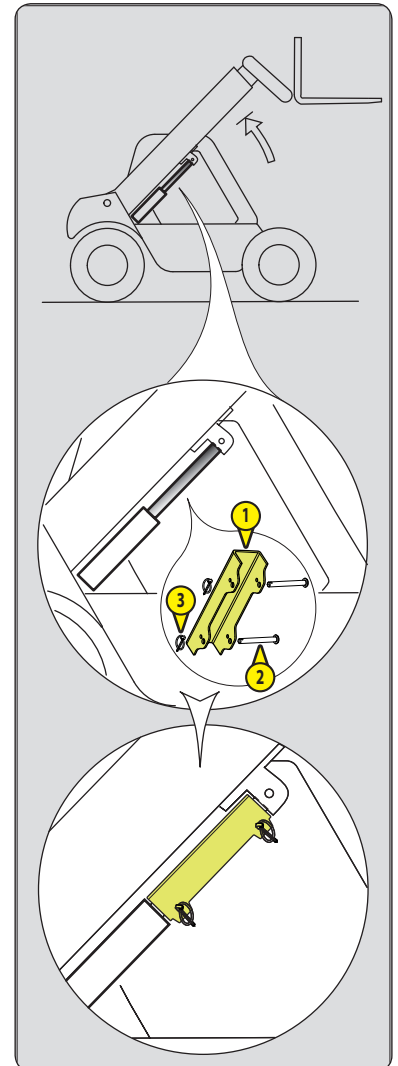

## MAINTENANCE

- Perform the periodic service (see: 3 - MAINTENANCE) to keep your lift truck in good working conditions. Failure to perform the periodic service may cancel the contractual guarantee.

### MAINTENANCE LOGBOOK

- The maintenance operations carried out in accordance with the recommendations given in part: 3 - MAINTENANCE and the other inspection, servicing or repair operations or modifications performed on the lift truck or its attachments shall be recorded in a maintenance logbook. The entry for each operation shall include details of the date of the works, the names of the individuals or companies having performed them, the type of operation and its frequency, if applicable. The part numbers of any lift truck items replaced shall also be indicated.

## LUBRICANT AND FUEL LEVELS

---

- Use the recommended lubricants (never use contaminated lubricants).
- Do not fill the fuel tank when the engine is running.
- Only fill up the fuel tank in areas specified for this purpose.
- Do not fill the fuel tank to the maximum level.
- Do not smoke or approach the lift truck with a flame, when the fuel tank is open or is being filled.

## HYDRAULIC

---

- Any work on the load handling hydraulic circuit is forbidden except for the operations described in part: 3 - MAINTENANCE.
- Do not attempt to loosen unions, hoses or any hydraulic component with the circuit under pressure.

### **⚠ IMPORTANT ⚠**

***BALANCING VALVE: It is dangerous to change the setting and remove the balancing valves or safety valves which may be fitted to your lift truck cylinders. The HYDRAULIC ACCUMULATORS that may be fitted on your lift truck are pressurised units. Removing these accumulators and their pipework is a dangerous operation and must only be performed by approved personnel (consult your dealer).***

## ELECTRICITY

---

- Do not short-circuit the starter relay to start the engine. If the forward/reverse selector is not in neutral and the parking brake is not applied, the lift truck may suddenly start to move.
- Do not drop metallic items on the battery.
- Disconnect the battery before working on the electrical circuit.

## WELDING

---

- Disconnect the battery before any welding operations on the lift truck.
- When carrying out electric welding work on the lift truck, connect the negative cable from the equipment directly to the part being welded, so as to avoid high tension current passing through the alternator.
- Never carry out welding or work which gives off heat on an assembled tyre. The heat would increase the pressure which could cause the tyre to explode.
- If the lift truck is equipped with an electronic control unit, disconnect this before starting to weld, to avoid the risk of causing irreparable damage to electronic components.

## WASHING THE LIFT TRUCK

---

- Clean the lift truck or at least the area concerned before any intervention.
- Remember to close and lock all accesses to the lift truck (doors, windows, cowls...).
- During washing, avoid the articulations and electrical components and connections.
- If necessary, protect against penetration of water, steam or cleaning agents, components susceptible of being damaged, particularly electrical components and connections and the injection pump.
- Clean the lift truck of any fuel, oil or grease trace.

## TRANSPORTING THE LIFT TRUCK

---

### **⚠ IMPORTANT ⚠**

***Transporting the lift truck involves real risks for the operator and others involved.***

- Towing, slinging or transporting the lift truck (see: 3 - MAINTENANCE: G - OCCASIONAL MAINTENANCE).

## IF THE LIFT TRUCK IS NOT TO BE USED FOR A LONG TIME

### INTRODUCTION

The following recommendations are intended to prevent the lift truck from being damaged when it is withdrawn from service for an extended period.

#### **⚠ IMPORTANT ⚠**

*Procedures to follow if the lift truck is not to be used for a long time and for starting it up again afterwards must be performed by your dealership. This long-term storage period must not exceed 12 months.*

### PREPARING THE LIFT TRUCK

- Clean the lift truck thoroughly.
- Check and repair any fuel, oil, water or air leaks.
- Replace or repair any worn or damaged parts.
- Wash the painted surfaces of the lift truck in clear and cold water and wipe them.
- Touch up the paintwork if necessary.
- Shut down the lift truck (see: OPERATING INSTRUCTIONS UNLADEN AND LADEN).
- Make sure the jib cylinder rods are all in retracted position.
- Release the pressure in the hydraulic circuits.

### PROTECTING THE ENGINE

- Fill the tank with fuel (see: 3 - MAINTENANCE: A - DAILY OR EVERY 10 HOURS SERVICE).
- Empty and replace the cooling liquid (see: 3 - MAINTENANCE: F - EVERY 2000 HOURS SERVICE).
- Leave the engine running at idling speed for a few minutes, then switch off.
- Replace the engine oil and oil filter (see: 3 - MAINTENANCE: D - EVERY 500 HOURS SERVICE).
- Run the engine for a short time so that the oil and cooling liquid circulate inside.
- Disconnect the battery and store it in a safe place away from the cold, after charging it to a maximum.
- Block the outlet with waterproof adhesive tape.
- Remove the drive belts and store them in a safe place.
- Disconnect the engine cut-off solenoid on the injection pump and carefully insulate the connection.

### PROTECTING THE LIFT TRUCK

- Set the lift truck on axle stands so that the tires are not in contact with the ground and release the parking brake.
- Protect cylinder rods which will not be retracted, from corrosion.
- Wrap the tires.

NOTE: If the lift truck is to be stored outdoors, cover it with a waterproof tarpaulin.

### BRINGING THE LIFT TRUCK BACK INTO SERVICE

- Remove the waterproof adhesive tape from all the holes.
- Refit and reconnect the battery.
- Remove the protection from the cylinder rods.
- Perform the daily service (see: 3 - MAINTENANCE: A - DAILY OR EVERY 10 HOURS SERVICE).
- Put the handbrake on and remove the axle stands.
- Empty and replace the fuel and replace the fuel filter (see: 3 - MAINTENANCE: D - EVERY 500 HOURS SERVICE).
- Refit and set the tension in the drive belts (see: 3 - MAINTENANCE: FILTERS CARTRIDGES AND BELTS).
- Turn the engine over with the starter, to allow the oil pressure to rise.
- Reconnect the engine cut-off solenoid.
- Lubricate the lift truck completely (see: 3 - MAINTENANCE: SERVICING SCHEDULE).

#### **⚠ IMPORTANT ⚠**

*Ensure the area is sufficiently ventilated before starting the lift truck.*

- Start up the lift truck, following the safety instructions and regulations (see: OPERATING INSTRUCTIONS UNLADEN AND LADEN).
- Run all the jib's hydraulic movements, concentrating on the ends of travel for each cylinder.

# LIFT TRUCK DISPOSAL



*Consult your dealer before disposing of your lift truck.*

## RECYCLING OF MATERIALS

---

### METALS

- Metals are 100 % recoverable and recyclable.

### PLASTICS

- Plastic parts are identified with a marking in accordance with current regulations.
- A limited range of materials is used to simplify the recycling process.
- The majority of plastic components are made of "thermoplastic" plastics, that are easily recycled by melting, granulating or grinding.

### RUBBER

- Tyres and seals can be ground for use in cement manufacture or to obtain reusable granules.

### GLASS

- Glass items can be removed and collected for processing by glaziers.

## ENVIRONMENTAL PROTECTION

---

By entrusting the maintenance of your lift truck to the MANITOU network, the risk of pollution is limited and the contribution to environmental protection contribution is made.

### WORN OR DAMAGED PARTS

- Do not dump them in the countryside.
- MANITOU and its network have signed-up to a scheme of environmental protection through recycling.

### USED OIL

- The MANITOU network organises the collection and processing of used oil products.
- By handing over your waste oil to MANITOU, the risk of pollution is limited.

### USED BATTERIES

- Do not throw away batteries, as they contain metals that are harmful for the environment.
- Return them to the MANITOU network or any other approved collection point.

NOTE: MANITOU aims to manufacture lift trucks that provide the best performance and limit polluting emissions.





# ***2 - DESCRIPTION***



# TABLE OF CONTENTS

## 2 - DESCRIPTION

<b>«EC» DECLARATION OF CONFORMITY</b>	<b>4</b>
<b>SAFETY PLATES AND STICKERS</b>	<b>6</b>
<b>IDENTIFICATION OF THE LIFT TRUCK</b>	<b>10</b>
<b>CHARACTERISTICS</b> MT 1435 EASY 75D ST3B S1	<b>12</b>
<b>CHARACTERISTICS</b> MT 1440 EASY 75D ST3B S1	<b>14</b>
<b>CHARACTERISTICS</b> MT 1840 EASY 75D ST3B S1	<b>16</b>
<b>FRONT AND REAR TIRES</b>	<b>18</b>
<b>DIMENSIONS AND LOAD CHART</b> MT 1435 EASY 75D ST3B S1	<b>20</b>
<b>DIMENSIONS AND LOAD CHART</b> MT 1440 EASY 75D ST3B S1	<b>22</b>
<b>DIMENSIONS AND LOAD CHART</b> MT 1840 EASY 75D ST3B S1	<b>24</b>
<b>VISIBILITY</b> MT 1435/1440 EASY 75D ST3B S1	<b>26</b>
<b>VISIBILITY</b> MT 1840 EASY 75D ST3B S1	<b>28</b>
<b>INSTRUMENTS AND CONTROLS</b>	<b>30</b>
<b>TOWING PIN AND HOOK</b>	<b>58</b>
<b>DESCRIPTION AND USE OF THE OPTIONS</b>	<b>60</b>

1) **DÉCLARATION «CE» DE CONFORMITÉ (originale)**  
**«EC» DECLARATION OF CONFORMITY (original)**

2) La société, *The company* : **MANITOU BF**

3) Adresse, *Address* : **430, rue de l'Aubinière - BP 10249 - 44158 - ANCENIS CEDEX - FRANCE**

4) Dossier technique, *Technical file* : **MANITOU BF - 430, rue de l'Aubinière  
BP 10249 - 44158 - ANCENIS CEDEX - FRANCE**

5) Constructeur de la machine décrite ci-après, *Manufacturer of the machine described below* :

**MT 1435 EASY 75D ST3B S1**

**MT 1440 EASY 75D ST3B S1**

**MT 1840 EASY 75D ST3B S1**

6) Déclare que cette machine, *Declares that this machine* :

7) Est conforme aux directives suivantes et à leurs transpositions en droit national,  
*Complies with the following directives and their transpositions into national law* :

**2006/42/CE**

8) Pour les machines annexe IV, *For annex IV machines* :

9) Numéro d'attestation, *Certificate number* :

10) Organisme notifié, *Notified body* :

15) Normes harmonisées utilisées, *Harmonised standards used* :

16) Normes ou dispositions techniques utilisées, *Standards or technical provisions used* :

17) Fait à, *Done at* :

18) Date, *Date* :

19) Nom du signataire, *Name of signatory* :

20) Fonction, *Function* :

21) Signature, *Signature* :

- bg :** 1) удостоверение за « CE » съответствие (оригинална), 2) Фирмата, 3) Адрес, 4) Техническо досие, 5) Фабрикант на описаната по-долу машина, 6) Обявява, че тази машина, 7) Отговаря на следните директиви и на тяхното съответствие национално право, 8) За машините към допълнение IV, 9) Номер на удостоверението, 10) Наименувана фирма, 15) хармонизирани стандарти използвани, 16) стандарти или технически правила, използвани, 17) Изработено в, 18) Дата, 19) Име на разписалия се, 20) Функция, 21) Функция.
- cs :** 1) ES prohlášení o shodě (původní), 2) Název společnosti, 3) Adresa, 4) Technická dokumentace, 5) Výrobce níže uvedeného stroje, 6) Prohlašuje, že tento stroj, 7) Je v souladu s následujícími směrnicemi a směrnicemi transponovanými do vnitrostátního práva, 8) Pro stroje v příloze IV, 9) Číslo certifikátu, 10) Notifikační orgán, 15) harmonizované normy použity, 16) Norema a technických pravidel používaných, 17) Místo vydání, 18) Datum vydání, 19) Jméno podepsaného, 20) Funkce, 21) Podpis.
- da :** 1) EF Overensstemmelseserklæring (original), 2) Firmaet, 3) Adresse, 4) tekniske dossier, 5) Konstruktor af nedenfor beskrevne maskine, 6) Erklærer, at denne maskine, 7) Overholder nedennævnte direktiver og disses gennemførelse til national ret, 8) For maskiner under bilag IV, 9) Certificat nummer, 10) Bemyndigede organ, 15) harmoniserede standarder, der anvendes, 16) standarder eller tekniske regler, 17) Udfærdiget i, 18) Dato, 19) Underskrivers navn, 20) Funktion, 21) Underskrift.
- de :** 1) EG-Konformitätserklärung (original), 2) Die Firma, 3) Adresse, 4) Technischen Unterlagen, 5) Hersteller der nachfolgend beschriebenen Maschine, 6) Erklärt, dass diese Maschine, 7) den folgenden Richtlinien und deren Umsetzung in die nationale Gesetzgebung entspricht, 8) Für die Maschinen laut Anhang IV, 9) Bescheinigungsnummer, 10) Benannte Stelle, 15) angewandten harmonisierten Normen, 16) angewandten sonstigen technischen Normen und Spezifikationen, 17) Ausgestellt in, 18) Datum, 19) Name des Unterzeichners, 20) Funktion, 21) Unterschrift.
- el :** 1) Δήλωση συμμόρφωσης CE (πρωτότυπο), 2) Η εταιρεία, 3) Διεύθυνση, 4) τεχνικό φάκελο, 5) Κατασκευάστρια του εξής περιγραφόμενου μηχανήματος, 6) Δηλώνει ότι αυτό το μηχάνημα, 7) Είναι σύμφωνο με τις εξής οδηγίες και τις προσαρμογές τους στο εθνικό δίκαιο, 8) Για τα μηχανήματα παραρτήματος IV, 9) Αριθμός δήλωσης, 10) Κοινοποιημένος φορέας, 15) εναρμονισμένα πρότυπα που χρησιμοποιούνται, 16) Πρότυπα ή τεχνικούς κανόνες που χρησιμοποιούνται, 16) Είναι σύμφωνο με τα εξής πρότυπα και τεχνικές διατάξεις, 17) Εν, 18) Ημερομηνία, 19) Όνομα του υπογράφοντος, 20) Θέση, 21) Υπογραφή.
- es :** 1) Declaración DE de conformidad (original), 2) La sociedad, 3) Dirección, 4) expediente técnico, 5) Constructor de la máquina descrita a continuación, 6) Declara que esta máquina, 7) Está conforme a las siguientes directivas y a sus transposiciones en derecho nacional, 8) Para las máquinas anexo IV, 9) Número de certificación, 10) Organismo notificado, 15) normas armonizadas utilizadas, 16) Otras normas o especificaciones técnicas utilizadas, 17) Hecho en, 18) Fecha, 19) Nombre del signatario, 20) Función, 21) Firma.
- et :** 1) EÜ vastavusdeklaratsioon (algupärane), 2) Äriühing, 3) Aadress, 4) Tehniline dokumentatsioon, 5) Seadme tootja, 6) Kinnitab, et see toode, 7) On vastavuses järgmiste direktiivide ja nende riigisisese õigussesse ülevõtmiseks vastuvõetud õigusaktidega, 8) IV lisas loetletud seadmete puhul, 9) Tunnistuse number, 10) Sertifitseerimisasutus, 15) kasutatud ühtlustatud standardite, 16) Muud standardites või spetsifikatsioonides kasutatakse, 17) Väljaandmise koht, 18) Väljaandmise aeg, 19) Allkirjastaja nimi, 20) Amet, 21) Allkiri.
- fi :** 1) EY-vaatimustenmukaisuusvakuutus (alkuperäiset), 2) Yritys, 3) Osoite, 4) teknisen eritelmän, 5) Jäljessä kuvatun koneen valmistaja, 6) Vakuuttaa, että tämä kone, 7) Täyttää seuraavien direktiivien sekä niitä vastaavien kansallisten säännösten vaatimukset, 8) Liitteen IV koneiden osalta, 9) Todistuksen numero, 10) Ilmoitettu laitos, 15) yhdenmukaistettuja standardeja käytetään, 16) muita standardeja tai eritelmät, 17) Paikka, 18) Aika, 19) Allekirjoittajan nimi, 20) Toimi, 21) Allekirjoitus.
- ga :** 1) « CE » dearbhú comhréireachta (bunaidh), 2) An comhlacht, 3) Seoladh, 4) comhad teicniúil, 5) Déantóir an innill a thuairiscítear thíos, 6) Dearbhaíonn sé go bhfuil an t-inneall, 7) Go gclóinn sé le na teoracha seo a leanas agus a trasuimh isteach i ndlí náisiúnta, 8) Le haghaidh innill an aguisín IV, 9) Uimhir teastais, 10) Comhlacht a chuireadh i bhfios, 15) caighdeán comhchuíbhithe a úsáidtear, 16) caighdeán eile nó sonraíochtaí teicniúla a úsáidtear, 17) Déanta ag, 18) Dáta, 19) Ainm an tsíniitheora, 20) Feidhm, 21) Síniú.
- hu :** 1) CE megfelelőési nyilatkozat (eredeti), 2) A vállalat, 3) Cím, 4) műszaki dokumentáció, 5) Az alábbi gép gyártója, 6) Kijelenti, hogy a gép, 7) Megfelel az alábbi irányelveknek valamint azok honosított előírásainak, 8) A IV. melléklet gépeihez, 9) Bizonylati szám, 10) Ertesített szervezet, 15) felhasznált harmonizált szabványok, 16) egyéb felhasznált műszaki szabványok és előírások hivatkozásai, 17) Kelt (hely), 18) Dátum, 19) Aláíró neve, 20) Funkció, 21) Aláírás.
- is :** 1) Samræmisvottorð ESB (upprunalega), 2) Fyrirtækið, 3) Aðsetur, 4) Tæknilegar skrá, 5) Smiður tækisins sem lýst er hér á eftir, 6) Staðfestir að tækið, 7) Samræmist eftirfarandi stöðlum og staðfærslu þeirra með hljóðsjón af þjóðarrétti, 8) Fyrir tækin í aukakafla IV, 9) Staðfestingarnúmer, 10) Tilkynt til, 15) samhæfða staðla sem notaðir, 16) önnur staðlar eða forskriftir notað, 17) Staður, 18) Dagsetning, 19) Nafn undirritaðs, 20) Staða, 21) Undirskrift.
- it :** 1) Dichiarazione CE di conformità (originale), 2) La società, 3) Indirizzo, 4) fascicolo tecnico, 5) Costruttore della macchina descritta di seguito, 6) Dichiara che questa macchina, 7) È conforme alle direttive seguenti e alle relative trasposizioni nel diritto nazionale, 8) Per le macchine Allegato IV, 9) Numero di Attestazione, 10) Organismo notificato, 15) norme armonizzate applicate, 16) altre norme e specifiche tecniche applicate, 17) Stabilità a, 18) Data, 19) Nome del firmatario, 20) Funzione, 21) Firma.
- lt :** 1) CE atitikties deklaracija (originalas), 2) Bendrovė, 3) Adresas, 4) Techninė byla, 5) Žemiau nurodytas įrenginio gamintojas, 6) Pareiškia, kad šis įrenginys, 7) Atitinka toliau nurodytas direktyvas ir į nacionalinius teisės aktus perkeltas jų nuostatas, 8) IV priedas dėl mašinu, 9) Serifikato Nr, 10) Paskelbtaji įstaiga, 15) suderintus standartus naudojamus, 16) Kiti standartai ir techninės specifikacijos, 17) Pasirašyta, 18) Data, 19) Pasirašiusio asmens vardas ir pavardė, 20) Pareigos, 21) Parašas.
- lv :** 1) EK atbilstības deklarācija (oriģināls), 2) Uzņēmums, 3) Adrese, 4) tehniskās lietas, 5) Tālāk aprakstītās iekārtas ražotājs, 6) Apliecina, ka šī iekārta, 7) Ir atbilstoša tālāk norādītajām direktīvām un to transpozīcijai nacionālajā likumdošanā, 8) Iekārtām IV pielikumā, 9) Apliecināts numurs, 10) Reģistrētā organizācija, 15) lietotajiem saskaņotajiem standartiem, 16) lietotajiem tehniskajiem standartiem un specifikācijām, 17) Sastādīts, 18) Datums, 19) Parakstītāja vārds, 20) Amats, 21) Paraksts.
- mt :** 1) Dikjarazzjoni ta' Konformità KE (originali), 2) Il-kumpanija, 3) Indirizz, 4) fajl tekniku, 5) Mani fattriċi tal-magna deskritta hawn isfel, 6) Tiddikjara li din il-magna, 7) Hija konformi hija konformi mad-Direttivi segwenti u l-lijgijiet li jimplementawhom fil-lijgi nazjonali, 8) Għall-magni fl-Anness IV, 9) Numru taċ-certifikat, 10) Entità notifikata, 15) l-istandards armonizzati użati, 16) standards tekniċi u specifikazzjonijiet oħra użati, 17) Magħmul f, 18) Data, 19) Isem il-firmatarju, 20) Kariga, 21) Firma.
- nl :** 1) EG-verklaring van overeenstemming (oorspronkelijke), 2) Het bedrijf, 3) Adres, 4) technisch dossier, 5) Constructeur van de hierna genoemde machine, 6) Verklaart dat deze machine, 7) In overeenstemming is met de volgende richtlijnen en hun omzettingen in het nationale recht, 8) Voor machines van bijlage IV, 9) Goedkeuringsnummer, 10) Aangezegde instelling, 15) gehanteerde geharmoniseerde normen, 16) andere gehanteerde technische normen en specificaties, 17) Opgemaakt te, 18) Datum, 19) Naam van ondergetekende, 20) Functie, 21) Handtekening.
- no :** 1) CE-samsvarserklæring (original), 2) Selskapet, 3) Adresse, 4) tekniske arkiv, 5) Fabrikant av følgende maskin, 6) Erklærer at denne maskinen, 7) Oppfyller kravene i følgende direktiver, med nasjonale gjennomføringsbestemmelser, 8) For maskinene i tillegg IV, 9) Attestnummer, 10) Notifisert organ, 15) harmoniserte standarder som brukes, 16) Andre standarder og spesifikasjoner brukt, 17) Utstedt i, 18) Dato, 19) Underskriverens navn, 20) Stilling, 21) Underskrift.
- pl :** 1) Deklaracja zgodności CE (oryginalne), 2) Spółka, 3) Adres, 4) dokumentacji technicznej, 5) Wykonawca maszyny opisanej poniżej, 6) Oświadczka, że ta maszyna, 7) Jest zgodna z następującymi dyrektywami i odpowiadającymi przepisami prawa krajowego, 8) Dla maszyn załącznik IV, 9) Numer certyfikatu, 10) Jednostka certyfikująca, 15) zastosowanych norm zharmonizowanych, 16) innych zastosowanych norm technicznych i specyfikacji, 17) Sporządzono w, 18) Data, 19) Nazwisko podpisującego, 20) Stanowisko, 21) Podpis.
- pt :** 1) Declaração de conformidade CE (original), 2) A empresa, 3) Morada, 4) processo técnico, 5) Fabricante da máquina descrita abaixo, 6) Declara que esta máquina, 7) Está em conformidade às diretivas seguintes e às suas transposições para o direito nacional, 8) Para as máquinas no anexo IV, 9) Número de certificado, 10) Entidade notificada, 15) normas harmonizadas utilizadas, 16) outras normas e especificações técnicas utilizadas, 17) Elaborado em, 18) Data, 19) Nome do signatário, 20) Cargo, 21) Assinatura.
- ro :** 1) Declarație de conformitate CE (originală), 2) Societatea, 3) Adresa, 4) cartii tehnice, 5) Constructor al mașinii descrise mai jos, 6) Declară că prezenta mașină, 7) Este conformă cu directivele următoare și cu transpunerea lor în dreptul național, 8) Pentru mașinile din anexa IV, 9) Număr de atestare, 10) Organism notificat, 15) standardele armonizate utilizate, 16) alte standarde și specificatii tehnice utilizate, 17) Încotmă la, 18) Data, 19) Numele persoanei care semnează, 20) Funcția, 21) Semnătură.
- sk :** 1) ES vyhlásenie o zhode (pôvodný), 2) Názo v spoločnosti, 3) Adresa, 4) technické dokumentácie, 5) Výrobca nižšie opísaného stroja, 6) Vyhlasuje, že tento stroj, 7) Je v súlade s nasledujúcimi smernicami a smernicami transponovanými do vnútroštátneho práva, 8) Pre stroje v prílohe IV, 9) Číslo certifikátu, 10) Notifikačný orgán, 15) použité harmonizované normy, 16) použité iné technické normy a predpisy, 17) Miesto vydania, 18) Dátum vydania, 19) Meno podpisujúceho, 20) Funkcia, 21) Podpis.
- sl :** 1) ES Izjava o ustreznosti (izvirna), 2) Družba, 3) Naslov, 4) tehnične dokumentacije, 5) Proizvajalac tukaj opisanega stroja, 6) Izjavlja, da je ta stroj, 7) Ustreza naslednjim direktivam in njihovi transpoziciji v državno pravo, 8) Za stroje priloga IV, 9) Številka potrdila, 10) Obvestilo organu, 15) uporabljene harmonizirane standarde, 16) druge uporabljene tehnične standarde in zahteve, 17) V, 18) Datum, 19) Ime podpisnika, 20) Funkcija, 21) Podpis.
- sv :** 1) CE-försäkran om överensstämmelse (original), 2) Företaget, 3) Adress, 4) tekniska dokumentationen, 5) Konstruktor av nedan beskrivna maskin, 6) Försäkrar att denna maskin, 7) Överensstämmer med nedanstående direktiv och införlivandet av dem i nationell rätt, 8) För maskinerna i bilaga IV, 9) Nummer för godkännande, 10) Organism som underrättats, 15) Harmoniserade standarder som använts, 16) andra tekniska standarder och specifikationer som använts, 17) Upprättat i, 18) Datum, 19) Namn på den som undertecknat, 20) Befattning, 21) Namnteckning.

# SAFETY PLATES AND STICKERS

## ⚠ IMPORTANT ⚠

Clean all the stickers and safety plates to make them legible.  
It is essential to replace stickers and safety plates which are illegible or damaged.  
Check the presence of stickers and safety plates after replacing any spare parts.

### EXTERNAL PLATES AND STICKERS

REF	PART NO.	DESCRIPTION
1	24653	- Slings point
2	305405	- Diesel fuel
3	52551668	- Air conditioning (OPTION)
4	288430	- Repair instruction
5	264476	- Boom electrical predisposition (OPTION) MT 1435/1440 ...
6	296998	- Maniscopic safety instruction
7	234805	- Hydraulic coupling instruction (OPTION)
8	234798	- Hydraulic oil
9	307508	- Battery cut-off
10	288174	- Accumulator Instructions
11	289101	- Tie-down point

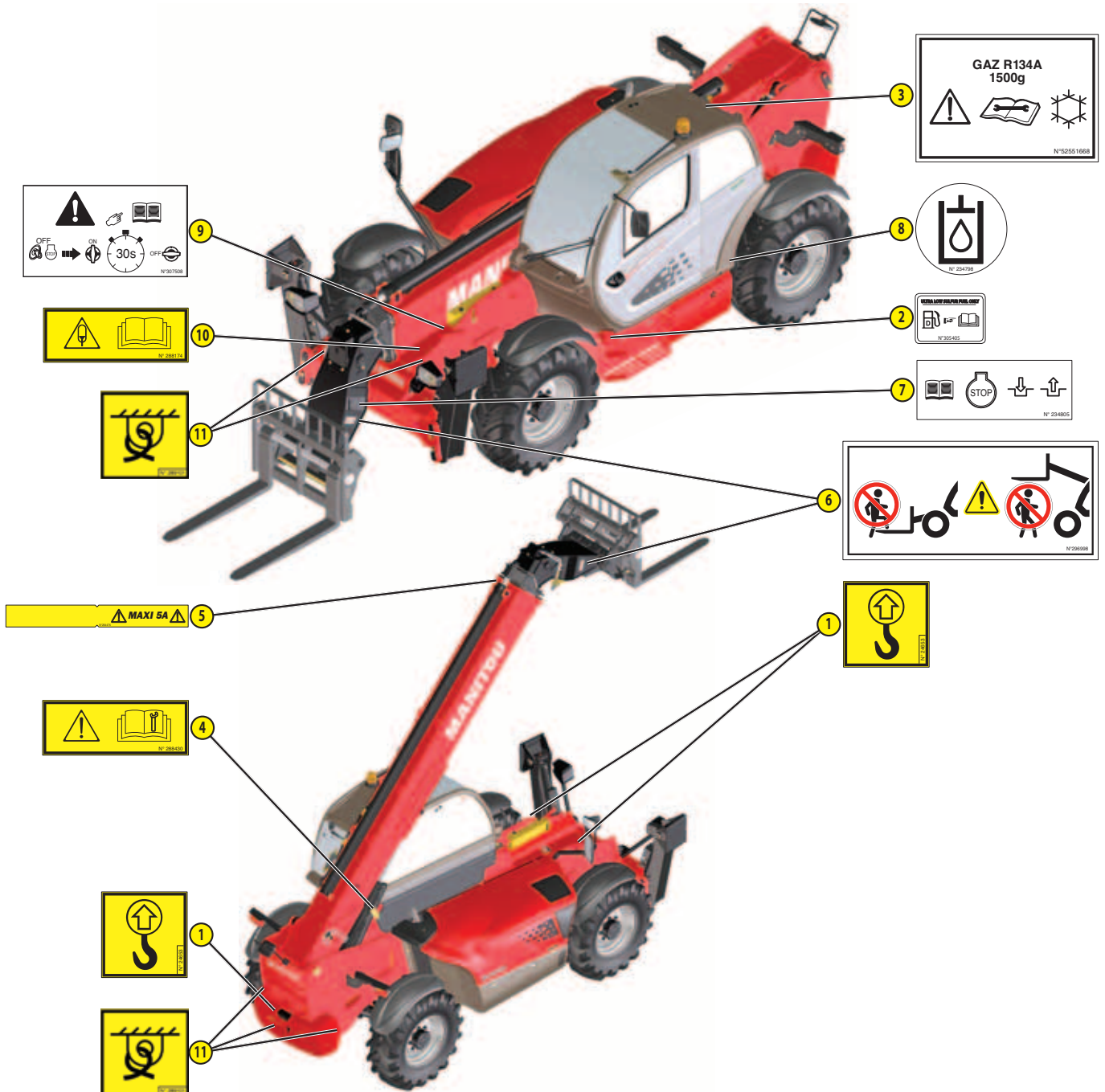

## STICKERS AND PLATES UNDER THE ENGINE HOOD

REF	PART NO.	DESCRIPTION
1	259398	- Water/diesel separator
2	52501046	- Anti-freeze
3	52538035	- Engine fuse
4	296741	- "Do not mount" safety instruction (OPTION)
5	52555686	- Battery troubleshooting

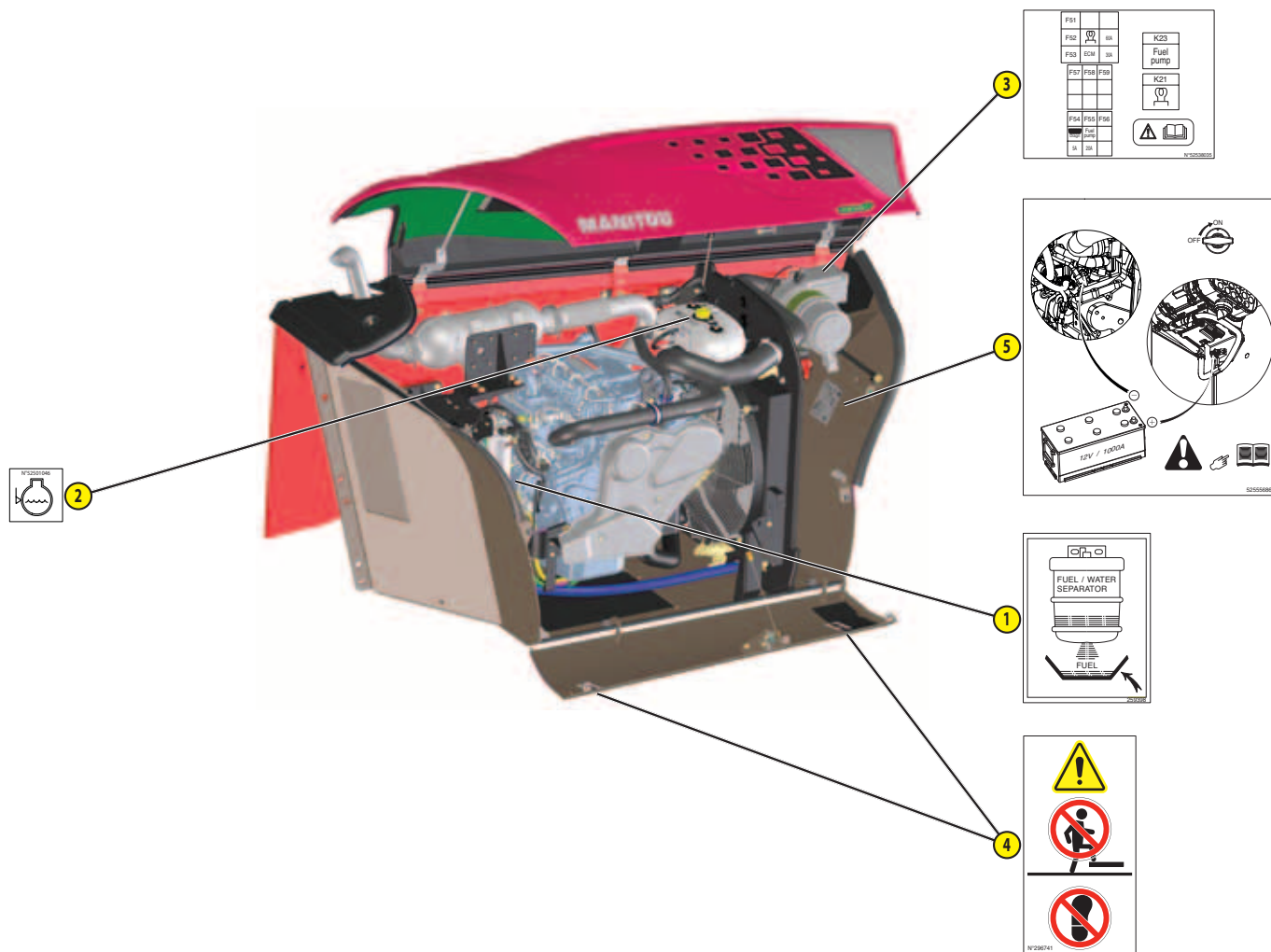

**PLATES AND STICKERS IN THE CAB**

REF	PART NO.	DESCRIPTION
1	268491	- Brake fluid instruction
2	239594	- Sound power level 104dB
3	279142	- Driver presence/start-up instruction
4	297734	- Operating mode management instruction
5	290183	- Bucket instruction on telescope
6	297393	- Back-scraping forbidden MT 1840 ...
7	261476	- Gear lever
8	184276	- Steering selection control
9	52521701	- Cab compliance
10	Consult your dealer	- Manufacturer's plate
11	52551322	- Fuses
12	261307	- Reach chart sheet
13	52515648	- Manipulator function MT 1435 ...
14	52515626	- Manipulator function MT 1440 ...
15	52515638	- Manipulator function MT 1840 ...
16	Consult your dealer	- Load chart without stabilisers
17	Consult your dealer	- Load chart on stabilisers
18	292240	- Greasing instruction + tire pressure MT 1435/1440 ...
19	292235	- Greasing instruction + tire pressure MT 1840 ...
20	272186	- Using bucket on TSDL (OPTION)
21	265284	- Lifting ring on single carriage (OPTION)

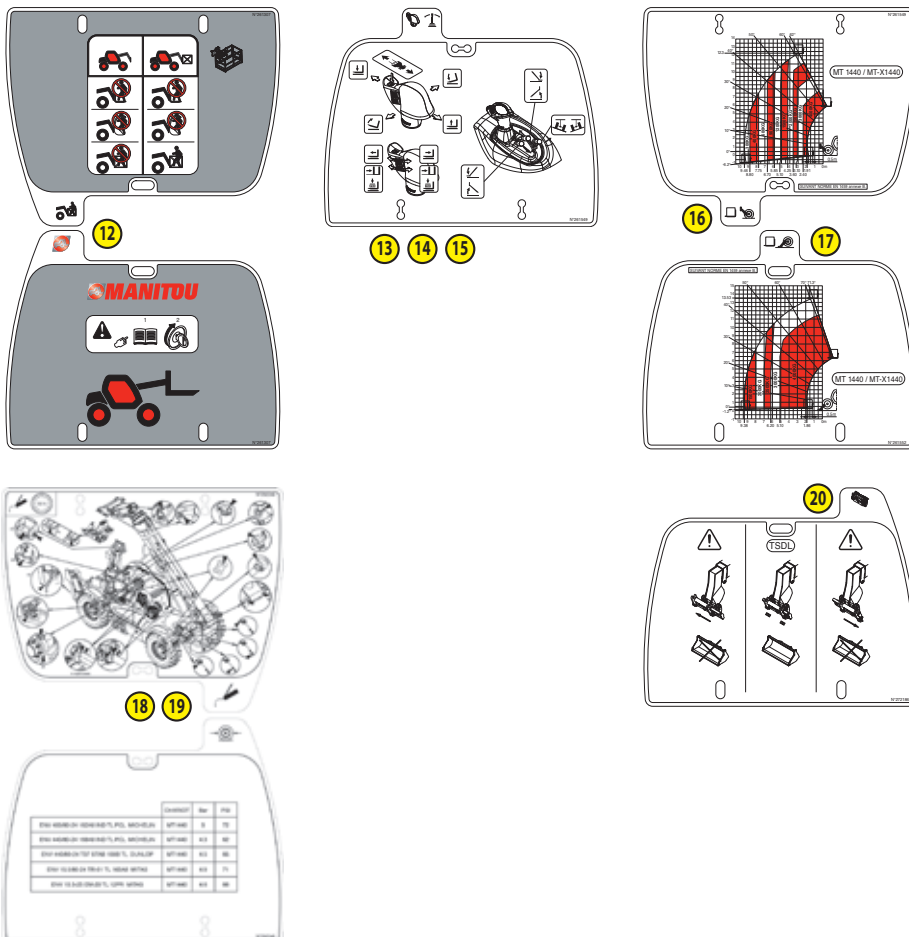



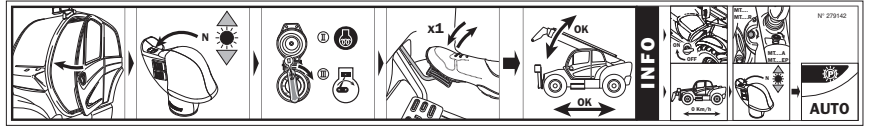
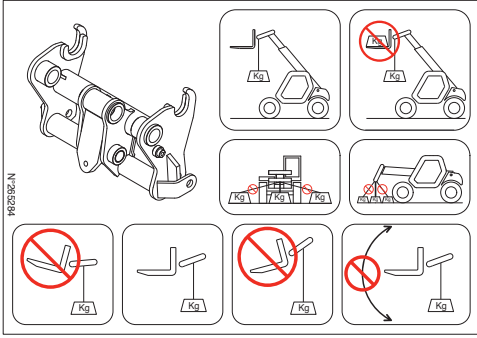

**MANITOU**  
MANITOU BF 44158 ANCENIS CEDEX FRANCE

MODELLO	MODELLO	SERIE	SERIE
Numero di identificazione	Numero di identificazione	Numero modello	Numero modello
N° di serie	N° di serie	Potenza ISO/75 kW	Potenza ISO/75 kW
Modello a vite	Modello a vite	Capacità nominale	Capacità nominale
P.T.P.A. Admisión para vehículos pesados	P.T.P.A.	P.T.P.A.	P.T.P.A.
Classe di trazione	Classe di trazione	Classe di trazione	Classe di trazione
Posizione del pneumatico (S)	Posizione del pneumatico (S)	Posizione del pneumatico (S)	Posizione del pneumatico (S)
Paese	Paese	Paese	Paese

N°295449

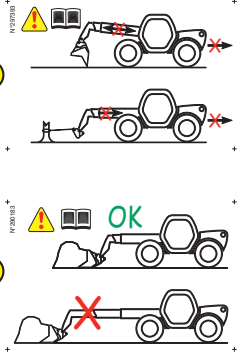
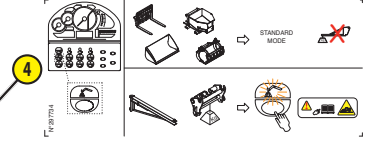
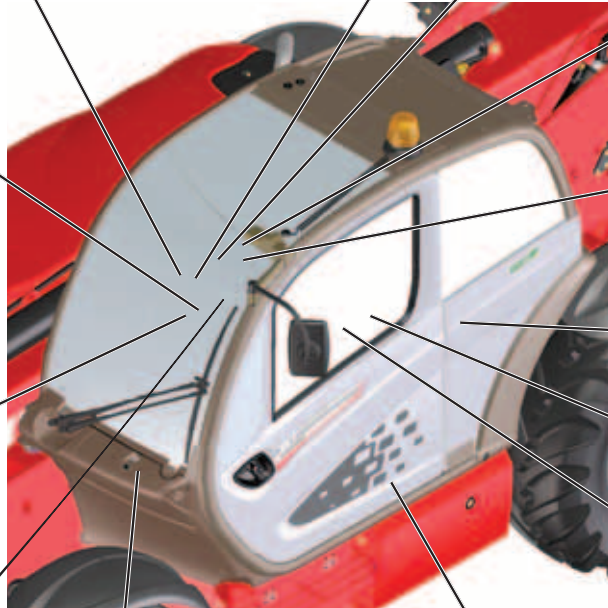

**MANITOU**  
MANITOU BF 44158 ANCENIS CEDEX FRANCE

Numero di identificazione

Numero modello

Numero di serie

Numero di serie

Numero di serie

Numero di serie

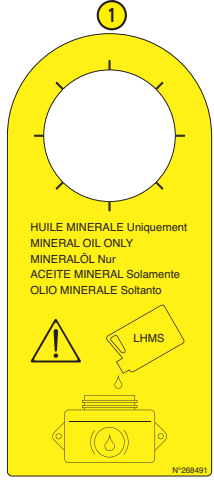
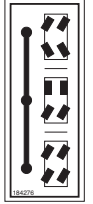

F46	F40	F30	F20	F10	2A	2A			
F45	F39	F29	F19	F9	2A	2A			
F44	F38	F28	F18	F8	2A	2A			
F43	F37	F27	F17	F7	2A	2A			
F42	F36	F26	F16	F6	2A	2A			
F41	F35	F25	F15	F5	2A	2A			
	F34	F24	F14	F4	2A	2A			
	F33	F23	F13	F3	2A	2A			
	F32	F22	F12	F2	2A	2A			
	F31	F21	F11	F1	2A	2A			

N° 52551322

## IDENTIFICATION OF THE LIFT TRUCK

As our policy is to promote a constant improvement of our products, our range of telescopic lift trucks may undergo certain modifications, without obligation for us to advise our customers.

When you order parts, or when you require any technical information, always specify:

NOTE: For the owner's convenience, it is recommended that a note of these numbers is made in the spaces provided, at the time of the delivery of the lift truck.

### LIFT TRUCK MANUFACTURER'S PLATE

- 1 - MODEL
- 2 - SERIES
- 3 - Year of manufacture
- 4 - Model year
- 5 - Serial Nr
- 6 - Power ISO 3046
- 7 - Unladen mass
- 8 - Authorized gross vehicle weight
- 9 - Rated capacity
- 10 - Drag strain
- 11 - Maximun vertical force (on trailer hook)
- 12 - Tyres pressure (bar)
- 13 - Homologation Nr

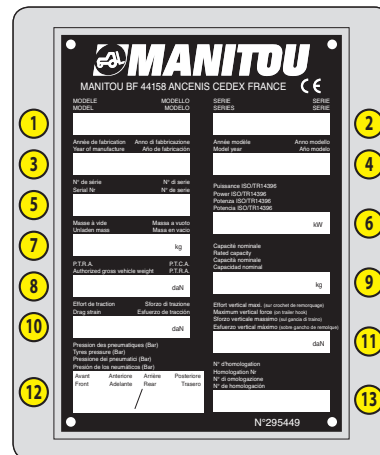

For any further technical information regarding your lift truck refer to chapter: 2 - DESCRIPTION: CHARACTERISTICS.

### I.C. ENGINE

- 1 - Type
- 2 - I.C. engine Nr

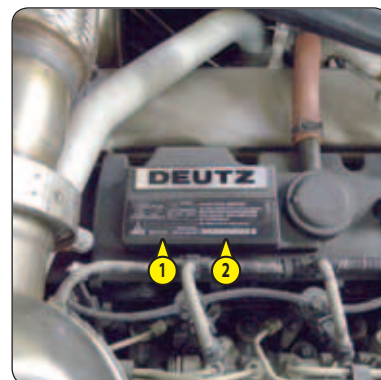

### GEAR BOX

- Type
- MANITOU reference
- Serial Nr

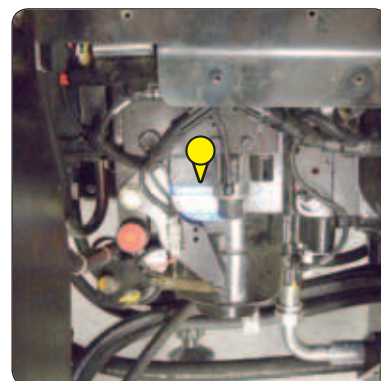

### FRONT AXLE

- Type
- Serial Nr
- MANITOU reference

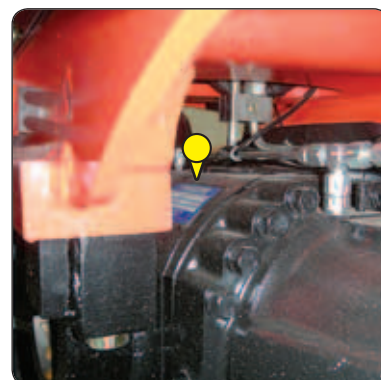

## REAR AXLE

---

- Type
- Serial Nr
- MANITOU reference

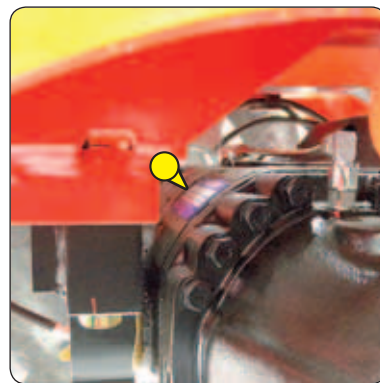

## CAB

---

- Type
- Serial Nr



## BOOM

---

- MANITOU reference
- Date of manufacture

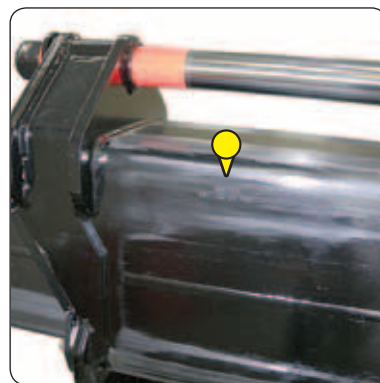

## CHASSIS

---

- Lift truck serial Nr

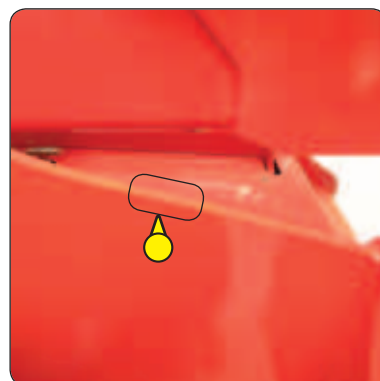

## PLATE MANUFACTURER OF THE ATTACHMENT

---

- Model
- Serial Nr
- Year of manufacture

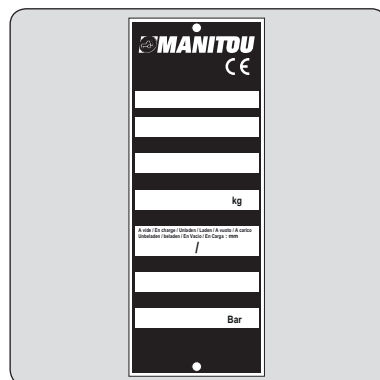

## CHARACTERISTICS

MT 1435 EASY 75D ST3B S1

I.C. ENGINE		
Type		DEUTZ TD 3.6 L4 2501-1714
Fuel		Diesel
Number of cylinders		4 in line
Suction		Supercharged
Injection system		Direct
Ignition sequence		1.3.4.2
Capacity	cm <sup>3</sup>	3621
Bore and stroke	mm	98 x 120
Compression ratio		18:1
Nominal speed laden	rpm	2200
Idling speed slow unladen	rpm	850
Max. speed unladen	rpm	2350
Power ISO/TR 3046	cv - kW	75 - 55,4
Power SAE J 1995	cv - kW	75 - 55,4
Maximum torque ISO/TR 3046	Nm	330 to 1600 rpm
Gravimetric efficiency ISO 5011	%	99,9
Type of cooling		By water
Fan		Puller

TRANSMISSION		
Gear box		DANA
- Type		Mechanical
- Forward/reverse selector		Electro-hydraulic
- Torque converter		DANA
- Number of forward speeds		4
- Number of reverse speeds		4
Angle gear box		-
Front axle		DANA
- Differential		Without locking
Rear axle		DANA
- Differential		Without locking
Drive wheels		4RM Permanent
- Switch for 2/4 drive wheels		No
Front tyres		ALLIANCE
- Size		400/80-24 A325 162A8 ATG
- Pressure	bar	5
Rear tyres		ALLIANCE
- Size		400/80-24 A325 162A8 ATG
- Pressure	bar	5

ELECTRIC CIRCUIT		
Battery	STANDARD	12 V - 110 Ah - 900 A EN
	OPTION	12 V - 180 Ah - 900 A EN
Alternator		14V - 95A
- Type		ISKRA AAK3868
Starter		12 V - 3,2 kW
- Type		ISKRA AZE 4668

BRAKE CIRCUIT		
Service brake		Hydraulic power brake
- Type of brake		Multidisk brake immersed in oil
- Type of control		Foot-operated for the front and rear axles
Parking brake		Low pressure brake
- Type of brake		Disk on gear-box output
- Type of control		Electro-hydraulic

SOUND AND VIBRATION		
Sound pressure level in the driver's cab LpA (according to standard NF EN 12053)	dB(A)	79 (cab closed) ; 00 (cab open)
Sound pressure (according to directive 2009/76)	dB(A)	00 (cab closed) ; 00 (cab open)
Sound pressure level ensured in the LwA environment (according to directive 2000/14/EC modified by directive 2005/88/EC)	dB(A)	102 (measured) ; 104 (ensured)
Sound level in motion (according to directive 2009/63)	dB(A)	
Average weighted acceleration on driver's body (according to standard NF EN 13059)	m/s <sup>2</sup>	1,0
The average weighted acceleration transmitted to the driver's hand/ arm system (according to standard ISO 5349-2)	m/s <sup>2</sup>	< 2,5
Standard seat vibration	m/s <sup>2</sup>	00 (lightweight operator) ; 00 (heavyweight operator)

<b>HYDRAULIC CIRCUIT</b>			
Hydraulic pump		Gear pump with flow divider on 2nd casing	
- Type		1st casing	2nd casing
- Capacity	cm <sup>3</sup>	45	27
- Max. rating capacity unladen	l/mn	106	64
- Flow rate at 1600 rpm	l/mn	72	44
Filtration			
- Return	µm	16	16
- Suction	µm	135	135
Maximum service pressure		270	
- Telescoping circuit	bar	180 / 270	
- Lifting circuit	bar	210 / 270	
- Tilt circuit	bar	270 / 200	
- Stabilizers Circuit	bar	270	
- Tilting corrector circuit (OPTION)	bar	270	
- Attachment circuit (OPTION)	bar	270	
- Steering circuit	bar	145	

<b>HYDRAULIC MOVEMENTS</b>			
Longitudinal stability limiter and warning device		Electronic	
Lifting motions (boom retracted)			
- Unladen lifting	s - m/mn	16 - 23,8	
- Laden lifting	s - m/mn	18 - 21,2	
- Unladen lowering	s - m/mn	12,4 - 30,7	
- Laden lowering	s - m/mn	13 - 29,3	
Telescoping motions (boom raised)			
- Unladen extending	s - m/mn	17,3 - 24,4	
- Laden extending	s - m/mn	18,7 - 26,4	
- Unladen retracting	s - m/mn	13 - 35,1	
- Laden retracting	s - m/mn	12,8 - 35,6	
Tilting movements			
- Unladen digging	s - °/s	4 - 31,5	
- Forward tilting unladen	s - °/s	4 - 31,5	

<b>SPECIFICATIONS AND WEIGHTS</b>			
Speed of movement for lift truck in standard configuration on flat ground (except particular conditions)			
Front unladen	1	km/h	5,4
	2	km/h	8,6
	3	km/h	15,5
	4	km/h	24,9
Rear unladen	1	km/h	5,1
	2	km/h	8,1
	3	km/h	15,1
	4	km/h	25,6
Standard attachment		TFF 35 MT1040	
- Weight with forks	kg	160	
- Weight of forks (each one)	kg	70	
Rated capacity with standard attachment	kg	3500	
Tipping load at maximum reach on stabilisers	kg	950	
Distance from the centre of gravity from the load to the lug of the forks	mm	500	
Standard lifting height	mm	13530	
Lift truck weight without attachment	kg	9400	
Lift truck weight with standard attachment			
- Unladen	kg	9700	
- At rated load	kg	13200	
Weight per axle with standard attachment (transport position)			
- Front unladen	kg	5460	
- Rear unladen	kg	4240	
- Front rated load	kg	11830	
- Rear rated load	kg	1370	
Weight per axle with standard attachment (boom extended)			
- Front rated load	kg	9640	
- Rear rated load	kg	160	
Contact pressure on the ground for the whole surface of each stabilizer at maximum load when tilting	kg/cm <sup>2</sup>	5,37	
Drag strain on the coupling hook			
- Unladen (sliding)	daN	6000	
- At rated load (transmission setting)	daN	7980	
Pull strain with open carrier (according to standard ISO 8313)	daN	7400	

## CHARACTERISTICS

MT 1440 EASY 75D ST3B S1

I.C. ENGINE		
Type		DEUTZ TD 3.6 L4 2501-1714
Fuel		Diesel
Number of cylinders		4 in line
Suction		Supercharged
Injection system		Direct
Ignition sequence		1.3.4.2
Capacity	cm <sup>3</sup>	3621
Bore and stroke	mm	98 x 120
Compression ratio		18:1
Nominal speed laden	rpm	2200
Idling speed slow unladen	rpm	850
Max. speed unladen	rpm	2350
Power ISO/TR 3046	cv - kW	75 - 55,4
Power SAE J 1995	cv - kW	75 - 55,4
Maximum torque ISO/TR 3046	Nm	330 to 1600 rpm
Gravimetric efficiency ISO 5011	%	99,9
Type of cooling		By water
Fan		Puller

TRANSMISSION		
Gear box		DANA
- Type		Mechanical
- Forward/reverse selector		Electro-hydraulic
- Torque converter		DANA
- Number of forward speeds		4
- Number of reverse speeds		4
Angle gear box		-
Front axle		DANA
- Differential		Without locking
Rear axle		DANA
- Differential		Without locking
Drive wheels		4RM Permanent
- Switch for 2/4 drive wheels		No
Front tyres		ALLIANCE
- Size		400/80-24 A325 162A8 ATG
- Pressure	bar	5
Rear tyres		ALLIANCE
- Size		400/80-24 A325 162A8 ATG
- Pressure	bar	5

ELECTRIC CIRCUIT		
Battery	STANDARD	12 V - 110 Ah - 900 A EN
	OPTION	12 V - 180 Ah - 900 A EN
Alternator		14V - 95A
- Type		ISKRA AAK3868
Starter		12 V - 3,2 kW
- Type		ISKRA AZE 4668

BRAKE CIRCUIT		
Service brake		Hydraulic power brake
- Type of brake		Multidisk brake immersed in oil
- Type of control		Foot-operated for the front and rear axles
Parking brake		Low pressure brake
- Type of brake		Disk on gear-box output
- Type of control		Electro-hydraulic

SOUND AND VIBRATION		
Sound pressure level in the driver's cab LpA (according to standard NF EN 12053)	dB(A)	79 (cab closed) ; 00 (cab open)
Sound pressure (according to directive 2009/76)	dB(A)	00 (cab closed) ; 00 (cab open)
Sound pressure level ensured in the LwA environment (according to directive 2000/14/EC modified by directive 2005/88/EC)	dB(A)	102 (measured) ; 104 (ensured)
Sound level in motion (according to directive 2009/63)	dB(A)	
Average weighted acceleration on driver's body (according to standard NF EN 13059)	m/s <sup>2</sup>	1,0
The average weighted acceleration transmitted to the driver's hand/ arm system (according to standard ISO 5349-2)	m/s <sup>2</sup>	< 2,5
Standard seat vibration	m/s <sup>2</sup>	00 (lightweight operator) ; 00 (heavyweight operator)

<b>HYDRAULIC CIRCUIT</b>			
Hydraulic pump		Gear pump with flow divider on 2nd casing	
- Type		1st casing	2nd casing
- Capacity	cm <sup>3</sup>	45	27
- Max. rating capacity unladen	l/mn	106	64
- Flow rate at 1600 rpm	l/mn	72	44
Filtration			
- Return	µm	16	16
- Suction	µm	135	135
Maximum service pressure		270	
- Telescoping circuit	bar	180 / 270	
- Lifting circuit	bar	210 / 270	
- Tilt circuit	bar	270 / 200	
- Stabilizers Circuit	bar	270	
- Tilting corrector circuit (OPTION)	bar	270	
- Attachment circuit (OPTION)	bar	270	
- Steering circuit	bar	145	

<b>HYDRAULIC MOVEMENTS</b>			
Longitudinal stability limiter and warning device		Electronic	
Lifting motions (boom retracted)			
- Unladen lifting	s - m/mn	16 - 23,8	
- Laden lifting	s - m/mn	18 - 21,2	
- Unladen lowering	s - m/mn	12,4 - 30,7	
- Laden lowering	s - m/mn	13 - 29,3	
Telescoping motions (boom raised)			
- Unladen extending	s - m/mn	17 - 24,4	
- Laden extending	s - m/mn	18,7 - 26,4	
- Unladen retracting	s - m/mn	13 - 35,1	
- Laden retracting	s - m/mn	12,8 - 35,6	
Tilting movements			
- Unladen digging	s - °/s	4 - 31,5	
- Forward tilting unladen	s - °/s	4 - 31,5	

<b>SPECIFICATIONS AND WEIGHTS</b>			
Speed of movement for lift truck in standard configuration on flat ground (except particular conditions)			
Front unladen	1	km/h	5,1
	2	km/h	8,1
	3	km/h	15,1
	4	km/h	25,6
Rear unladen	1	km/h	5,1
	2	km/h	8,1
	3	km/h	15,1
	4	km/h	25,6
Standard attachment		TFF 45 MT1040	
- Weight with forks	kg	228	
- Weight of forks (each one)	kg	71	
Rated capacity with standard attachment	kg	4000	
Tipping load at maximum reach on stabilisers	kg	1960	
Distance from the centre of gravity from the load to the lug of the forks	mm	500	
Standard lifting height	mm	13530	
Lift truck weight without attachment	kg	10485	
Lift truck weight with standard attachment			
- Unladen	kg	10855	
- At rated load	kg	14855	
Weight per axle with standard attachment (transport position)			
- Front unladen	kg	5305	
- Rear unladen	kg	5550	
- Front rated load	kg	12655	
- Rear rated load	kg	2200	
Weight per axle with standard attachment (boom extended)			
- Front rated load	kg	10935	
- Rear rated load	kg	220	
Contact pressure on the ground for the whole surface of each stabilizer at maximum load when tilting	kg/cm <sup>2</sup>	5,37	
Drag strain on the coupling hook			
- Unladen (sliding)	daN	7900	
- At rated load (transmission setting)	daN	8320	
Pull strain with open carrier (according to standard ISO 8313)	daN	7400	

## CHARACTERISTICS

MT 1840 EASY 75D ST3B S1

I.C. ENGINE		
Type		DEUTZ TD 3.6 L4 2501-1714
Fuel		Diesel
Number of cylinders		4 in line
Suction		Supercharged
Injection system		Direct
Ignition sequence		1.3.4.2
Capacity	cm <sup>3</sup>	3621
Bore and stroke	mm	98 x 120
Compression ratio		18:1
Nominal speed laden	rpm	2200
Idling speed slow unladen	rpm	850
Max. speed unladen	rpm	2350
Power ISO/TR 3046	cv - kW	75 - 55,4
Power SAE J 1995	cv - kW	75 - 55,4
Maximum torque ISO/TR 3046	Nm	330 to 1600 rpm
Gravimetric efficiency ISO 5011	%	99,9
Type of cooling		By water
Fan		Puller

TRANSMISSION		
Gear box		DANA
- Type		Mechanical
- Forward/reverse selector		Electro-hydraulic
- Torque converter		DANA
- Number of forward speeds		4
- Number of reverse speeds		4
Angle gear box		-
Front axle		DANA
- Differential		Without locking
Rear axle		DANA
- Differential		Without locking
Drive wheels		4RM Permanent
- Switch for 2/4 drive wheels		No
Front tyres		ALLIANCE
- Size		440/80-24 A325 168A8 ATG
- Pressure	bar	4,5
Rear tyres		ALLIANCE
- Size		440/80-24 A325 168A8 ATG
- Pressure	bar	4,5

ELECTRIC CIRCUIT		
Battery	STANDARD	12 V - 110 Ah - 900 A EN
	OPTION	12 V - 180 Ah - 900 A EN
Alternator		14V - 95A
- Type		ISKRA AAK3868
Starter		12 V - 3,2 kW
- Type		ISKRA AZE 4668

BRAKE CIRCUIT		
Service brake		Hydraulic power brake
- Type of brake		Multidisk brake immersed in oil
- Type of control		Foot-operated for the front and rear axles
Parking brake		Low pressure brake
- Type of brake		Disk on gear-box output
- Type of control		Electro-hydraulic

SOUND AND VIBRATION		
Sound pressure level in the driver's cab LpA (according to standard NF EN 12053)	dB(A)	79 (cab closed) ; 00 (cab open)
Sound pressure (according to directive 2009/76)	dB(A)	00 (cab closed) ; 00 (cab open)
Sound pressure level ensured in the LwA environment (according to directive 2000/14/EC modified by directive 2005/88/EC)	dB(A)	102 (measured) ; 104 (ensured)
Sound level in motion (according to directive 2009/63)	dB(A)	
Average weighted acceleration on driver's body (according to standard NF EN 13059)	m/s <sup>2</sup>	1,0
The average weighted acceleration transmitted to the driver's hand/ arm system (according to standard ISO 5349-2)	m/s <sup>2</sup>	< 2,5
Standard seat vibration	m/s <sup>2</sup>	00 (lightweight operator) ; 00 (heavyweight operator)



<b>HYDRAULIC CIRCUIT</b>			
Hydraulic pump		Gear pump with flow divider on 2nd casing	
- Type		1st casing	2nd casing
- Capacity	cm <sup>3</sup>	45	27
- Max. rating capacity unladen	l/mn	106	64
- Flow rate at 1600 rpm	l/mn	72	44
Filtration			
- Return	µm	16	16
- Suction	µm	135	135
Maximum service pressure		270	
- Telescoping circuit	bar	210 / 270	
- Lifting circuit	bar	210 / 270	
- Tilt circuit	bar	270 / 200	
- Stabilizers Circuit	bar	270	
- Tilting corrector circuit (OPTION)	bar	270	
- Attachment circuit (OPTION)	bar	270	
- Steering circuit	bar	145	

<b>HYDRAULIC MOVEMENTS</b>			
Longitudinal stability limiter and warning device		Electronic	
Lifting motions (boom retracted)			
- Unladen lifting	s - m/mn	17,5 - 23	
- Laden lifting	s - m/mn	20 - 20,1	
- Unladen lowering	s - m/mn	13,1 - 30,7	
- Laden lowering	s - m/mn	14 - 28,7	
Telescoping motions (boom raised)			
- Unladen extending	s - m/mn	16,5 - 39,5	
- Laden extending	s - m/mn	17 - 40,7	
- Unladen retracting	s - m/mn	16,6 - 40,4	
- Laden retracting	s - m/mn	16 - 42	
Tilting movements			
- Unladen digging	s - °/s	4,83 - 26,1	
- Forward tilting unladen	s - °/s	4,25 - 29,6	

<b>SPECIFICATIONS AND WEIGHTS</b>			
Speed of movement for lift truck in standard configuration on flat ground (except particular conditions)			
Front unladen	1	km/h	5,4
	2	km/h	8,5
	3	km/h	16
	4	km/h	27
Rear unladen	1	km/h	5,4
	2	km/h	8,5
	3	km/h	16
	4	km/h	27
Standard attachment		TFF 45 MT1040	
- Weight with forks	kg	228	
- Weight of forks (each one)	kg	71	
Rated capacity with standard attachment	kg	4000	
Tipping load at maximum reach on stabilisers	kg	1105	
Distance from the centre of gravity from the load to the lug of the forks	mm	500	
Standard lifting height	mm	17550	
Lift truck weight without attachment	kg	11340	
Lift truck weight with standard attachment			
- Unladen	kg	11710	
- At rated load	kg	15710	
Weight per axle with standard attachment (transport position)			
- Front unladen	kg	5510	
- Rear unladen	kg	6200	
- Front rated load	kg	12940	
- Rear rated load	kg	2770	
Weight per axle with standard attachment (boom extended)			
- Front rated load	kg	11510	
- Rear rated load	kg	600	
Contact pressure on the ground for the whole surface of each stabilizer at maximum load when tilting	kg/cm <sup>2</sup>	5,49	
Drag strain on the coupling hook			
- Unladen (sliding)	daN	7900	
- At rated load (transmission setting)	daN	8320	
Pull strain with open carrier (according to standard ISO 8313)	daN	7400	

## FRONT AND REAR TIRES

MT 1435 ...		PRESSURE (bar)	TYRE LOAD (kg)			
			FRONT UNLADEN	FRONT LADEN	REAR UNLADEN	REAR LADEN
ALLIANCE	400/80-24 A325 162A8 ATG	5	2750	5900	2100	700
GALAXY	15.5-25 16PR GIRAFFE L2	5,2				
MICHELIN	400/80-24 162A8 TUBELESS	5				
MITAS	15.5-25 12PR EM-20 TUBELESS	4,6				

MT 1440 ...		PRESSURE (bar)	TYRE LOAD (kg)			
			FRONT UNLADEN	FRONT LADEN	REAR UNLADEN	REAR LADEN
ALLIANCE	400/80-24 A325 162A8 ATG	5	2650	6350	2750	1100
GALAXY	15.5-25 16PR GIRAFFE L2	5,2				
MICHELIN	400/80-24 162A8 TUBELESS	5				
MITAS	15.5-25 12PR EM-20 TUBELESS	4,6				

MT 1840 ...		PRESSURE (bar)	TYRE LOAD (kg)			
			FRONT UNLADEN	FRONT LADEN	REAR UNLADEN	REAR LADEN
ALLIANCE	440/80-24 A325 168A8 ATG	4,5	2750	6450	3050	1400
GALAXY	15.5-25 16PR GIRAFFE L2	5,2				
MICHELIN	440/80-24 168A8 TUBELESS	4,5				
MITAS	15.5-25 12PR EM-20 TUBELESS	4,6				

		PRESSURE (bar)	LOAD (kg)	PRESSURE ON THE CONTACT SURFACE (kg/cm <sup>2</sup> )		AREA OF THE CONTACT SURFACE (cm <sup>2</sup> )	
				HARD SOIL	LOOSE SOIL	HARD SOIL	LOOSE SOIL
ALLIANCE	400/80-24 A325 162A8 ATG	5	700				
			1100				
			2100				
			2650				
			2750				
			5900				
	440/80-24 A325 168A8 ATG	4,5	1400				
			2750				
			3050				
			6450				
GALAXY	15.5-25 16PR GIRAFFE L2	5,2	700				
			1100				
			1400				
			2100				
			2650				
			2750				
			3050				
			5900				
			6350				
			6450				
MICHELIN	400/80-24 162A8 TUBELESS	5	700	6,10	0,43	122	1428
			1100	6,90	0,70	159	1548
			2100	8,52	1,11	240	1847
			2650	9,38	1,30	282	2000
			2750	9,53	1,30	289	2007
			5900	12,36	1,93	472	2981
	440/80-24 168A8 TUBELESS	4,5	1400	7,13	0,85	193	1650
			2750	9,10	1,33	302	2064
			3050	9,40	1,40	323	2156
			6450	12,30	2,00	526	3200
MITAS	15.5-25 12PR EM-20 TUBELESS	4,6	700				
			1100				
			1400				
			2100				
			2650				
			2750				
			3050				
			5900				
			6350				
			6450				

# DIMENSIONS AND LOAD CHART MT 1435 EASY 75D ST3B S1

A	mm	1200
B	mm	3070
C	mm	1905
C1	mm	1790
D	mm	6135
D1	mm	6020
D2	mm	4859
E	mm	7335
F	mm	1960
F1	mm	1960
G	mm	384
G1	mm	367
G2	mm	380
G3	mm	355
I	mm	1160
J	mm	892
K	mm	1040
L	mm	50
N	mm	1855
O	mm	125
P2	°	34
P3	°	33
R	mm	3779
S	mm	8626
T	mm	4183
U1	mm	2452
U2	mm	2640
V	mm	5468
V1	mm	1285
V2	mm	3986
W	mm	2374
W1	mm	3793
W2	mm	1134
W3	mm	2422
Y	°	12
Z	°	114

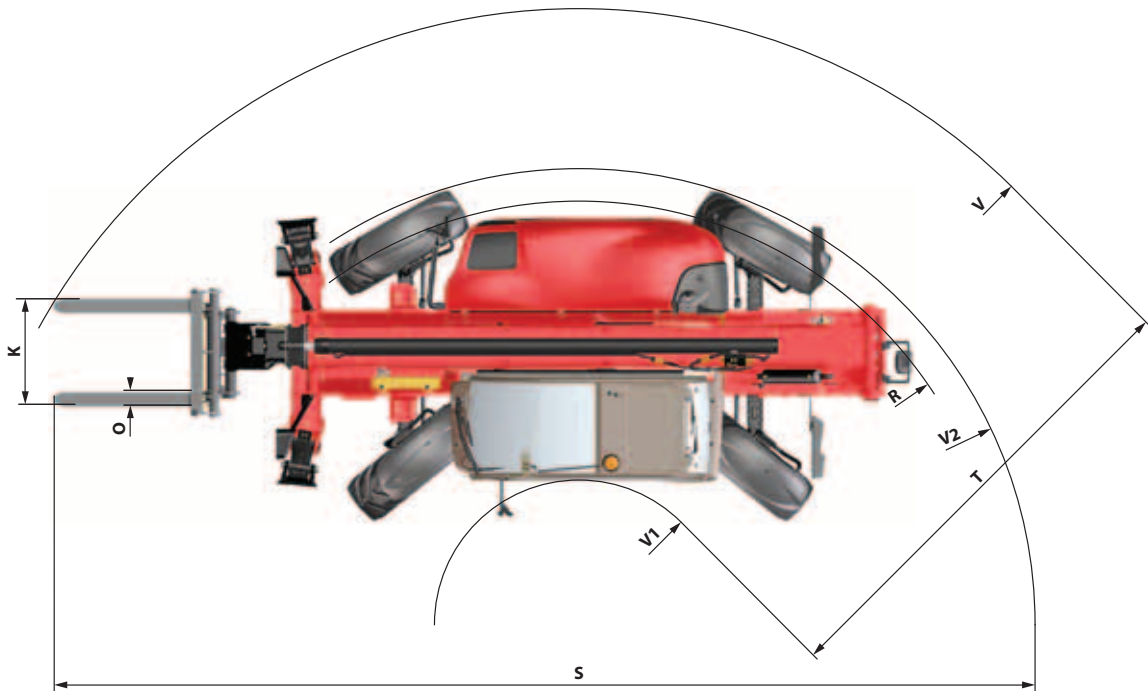
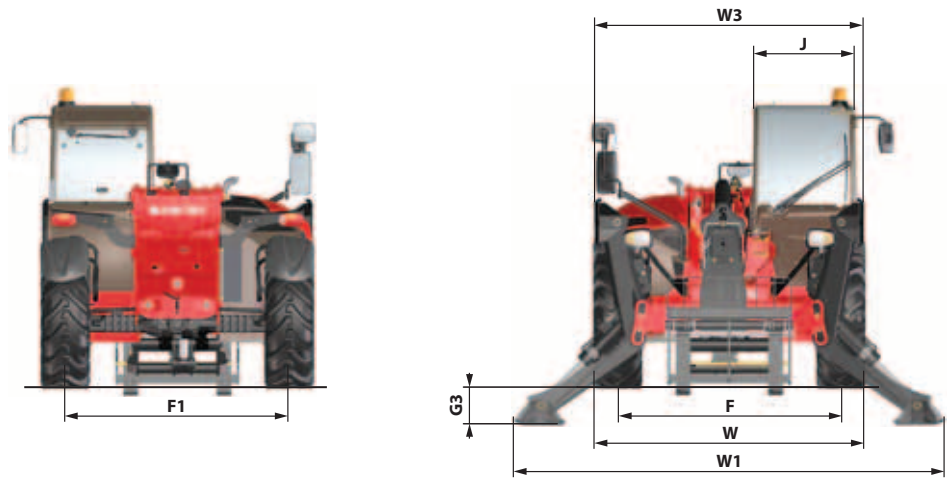
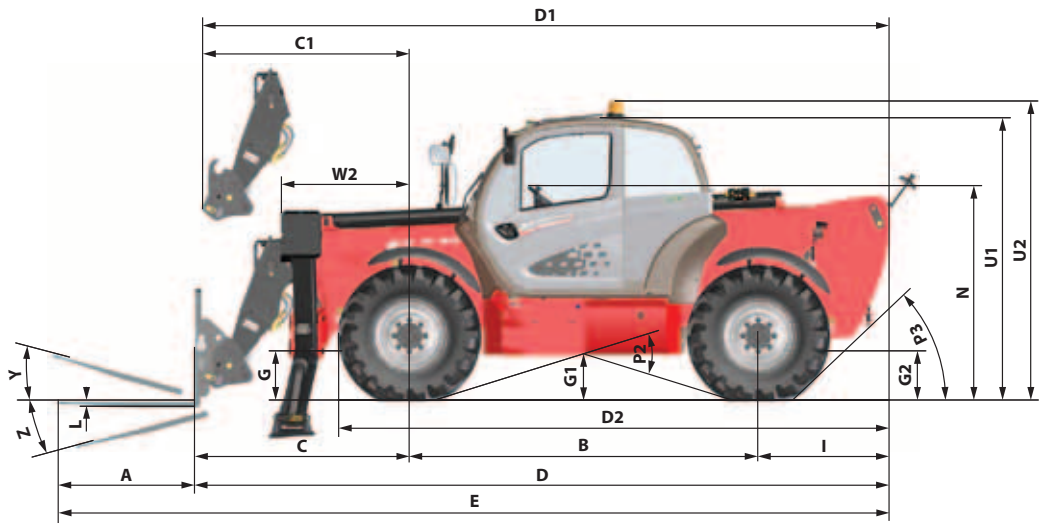

SUIVANT NORME EN 1459 annexe B.

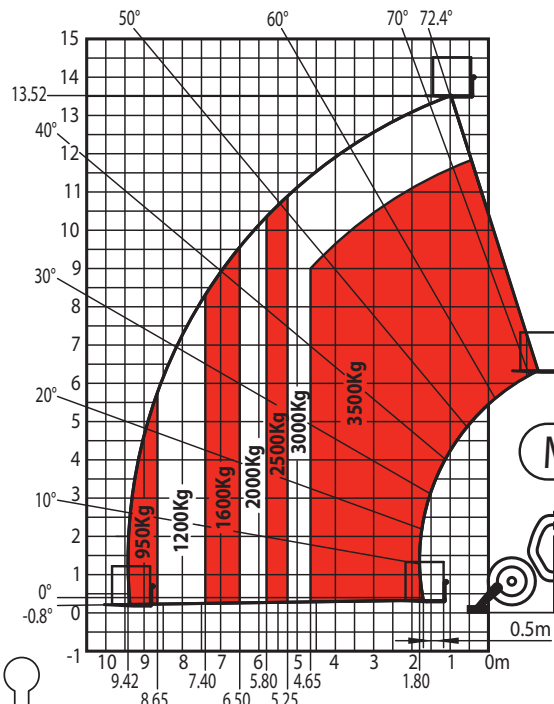

MT1435/MT-X1435

N°52515646

N°52515648

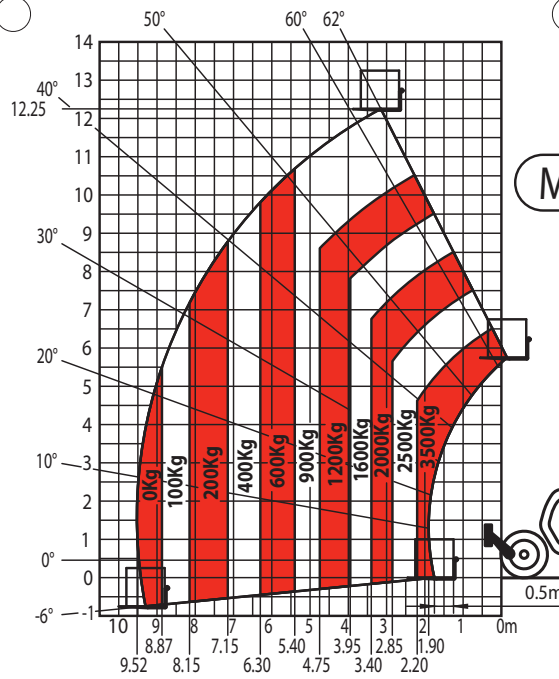

MT1435/MT-X1435

SUIVANT NORME EN 1459 annexe B.

# DIMENSIONS AND LOAD CHART MT 1440 EASY 75D ST3B S1

A	mm	1200
B	mm	3070
C	mm	1905
C1	mm	1790
D	mm	6135
D1	mm	6020
D2	mm	4859
E	mm	7335
F	mm	1960
F1	mm	1960
G	mm	384
G1	mm	367
G2	mm	380
G3	mm	355
I	mm	1160
J	mm	892
K	mm	1040
L	mm	50
N	mm	1855
O	mm	125
P2	°	34
P3	°	33
R	mm	3779
S	mm	8626
T	mm	4183
U1	mm	2452
U2	mm	2640
V	mm	5468
V1	mm	1285
V2	mm	3986
W	mm	2374
W1	mm	3793
W2	mm	1134
W3	mm	2422
Y	°	12
Z	°	114

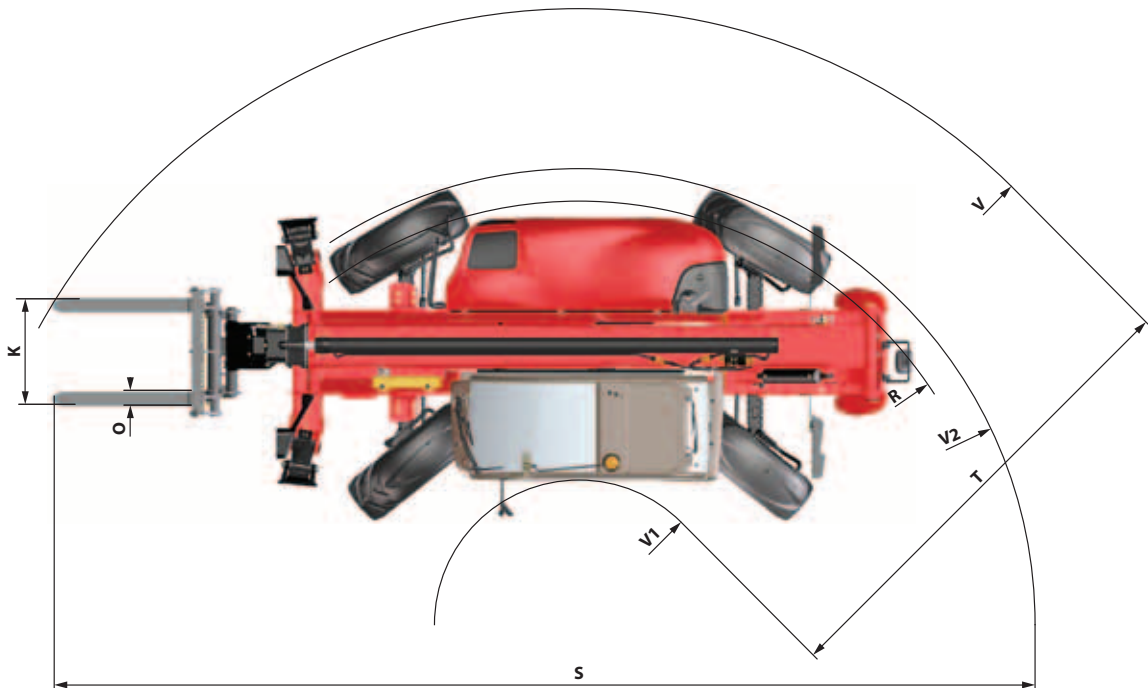
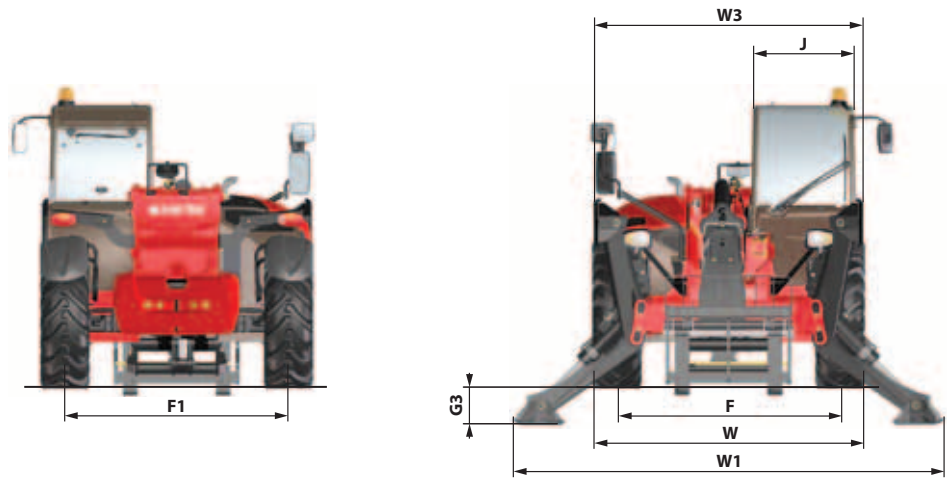
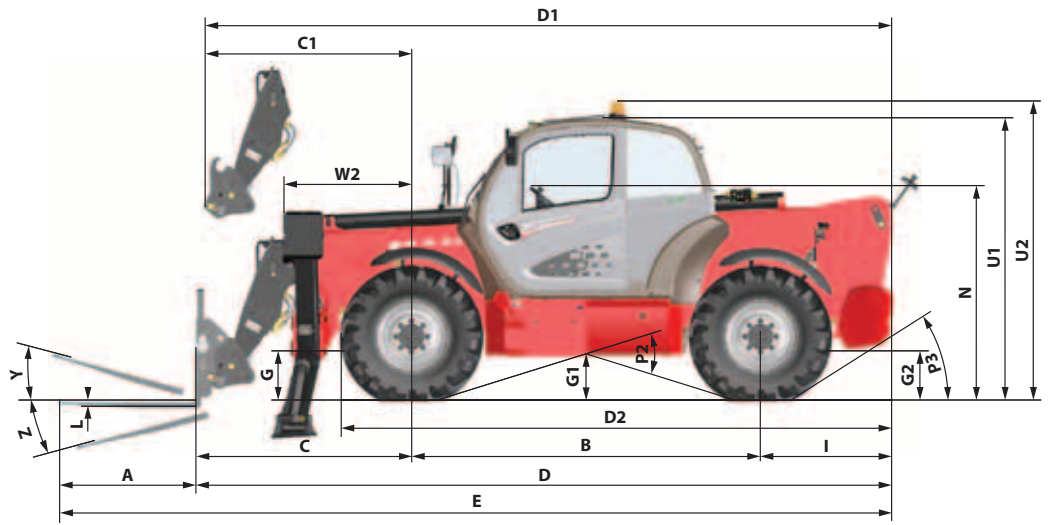

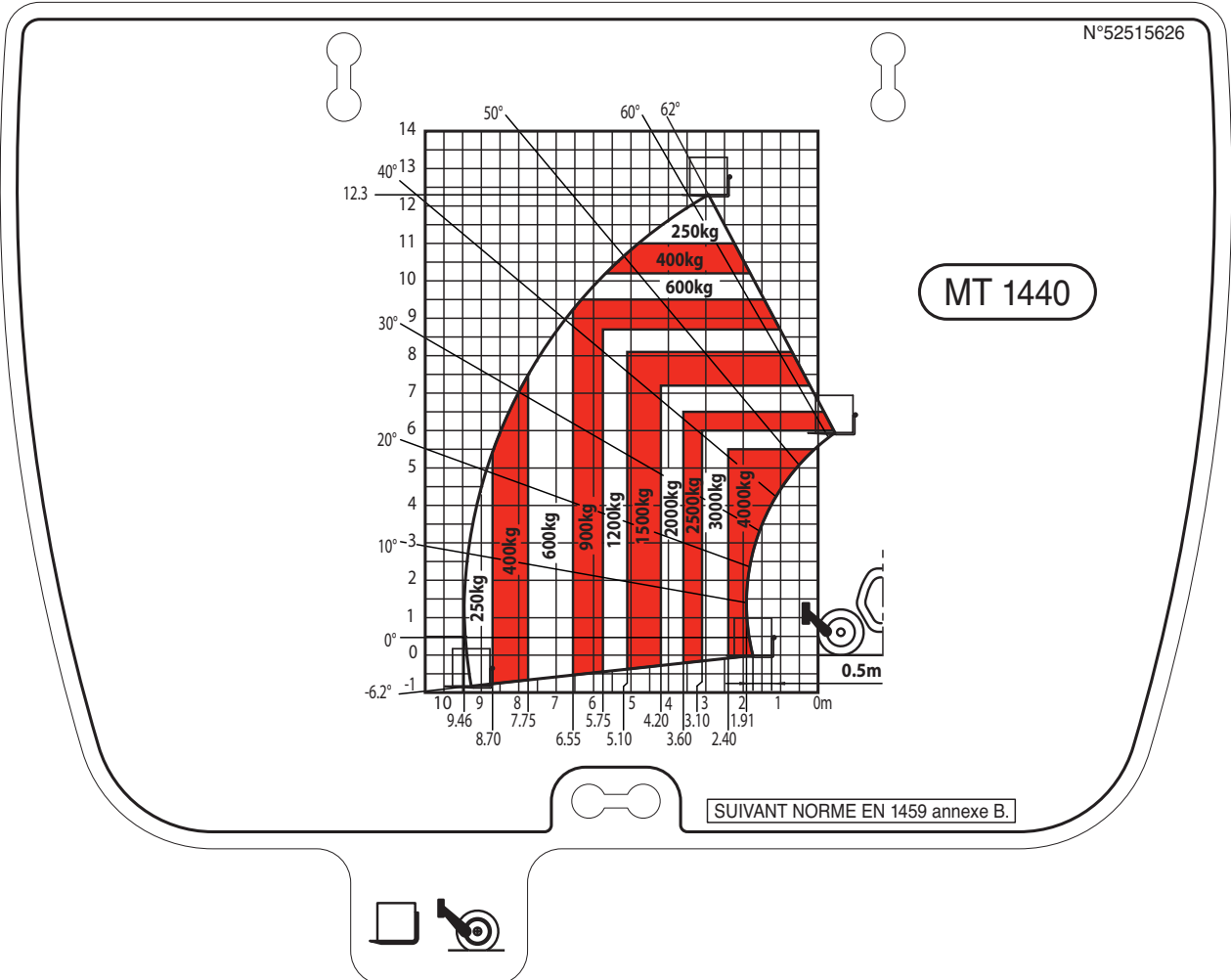
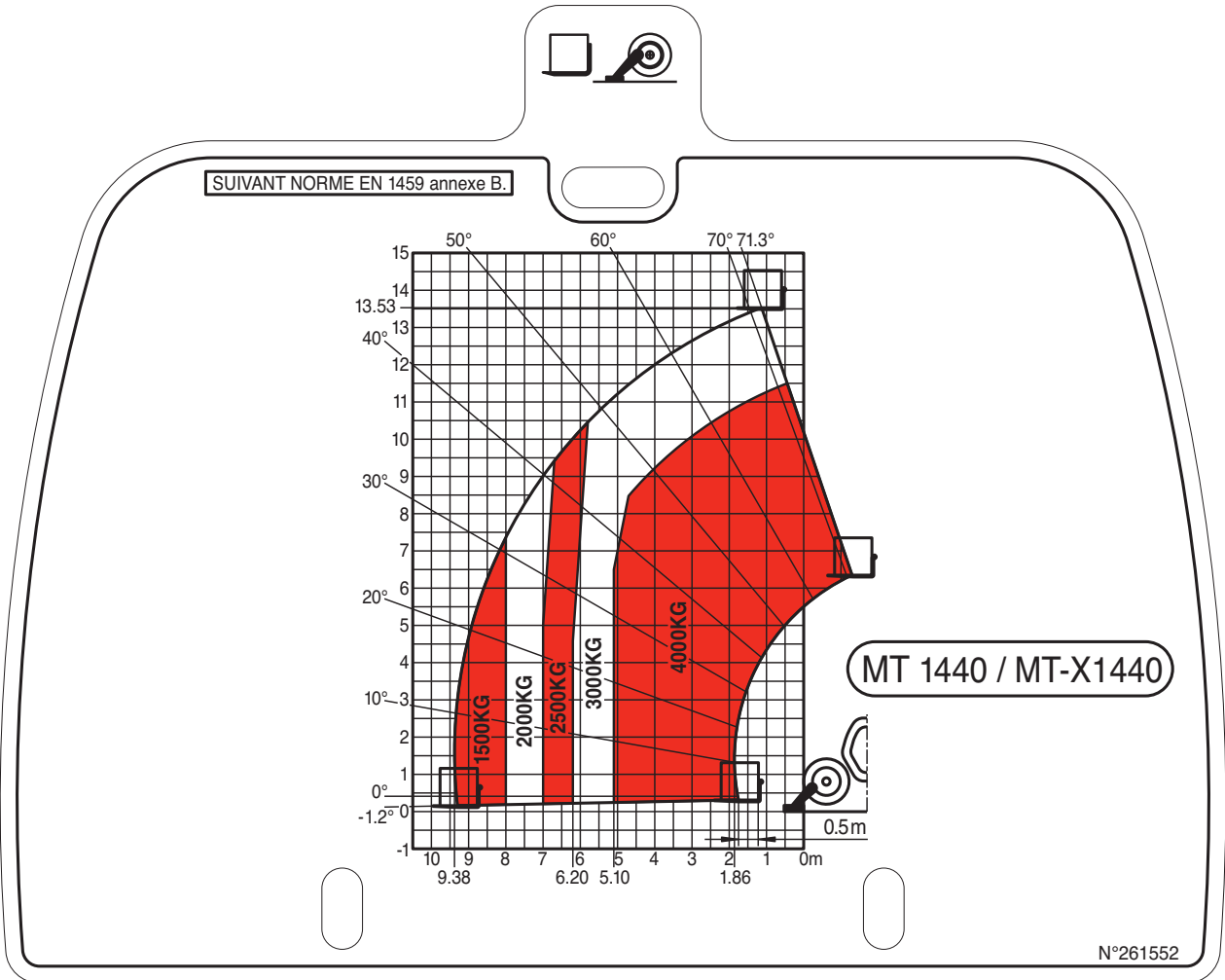

# DIMENSIONS AND LOAD CHART MT 1840 EASY 75D ST3B S1

<b>A</b>	mm	1200
<b>B</b>	mm	3070
<b>C</b>	mm	2044
<b>C1</b>	mm	1929
<b>D</b>	mm	6274
<b>D1</b>	mm	6159
<b>D2</b>	mm	4894
<b>E</b>	mm	7474
<b>F</b>	mm	1960
<b>F1</b>	mm	1960
<b>G</b>	mm	437
<b>G1</b>	mm	420
<b>G2</b>	mm	433
<b>G3</b>	mm	302
<b>I</b>	mm	1160
<b>J</b>	mm	892
<b>K</b>	mm	1040
<b>L</b>	mm	50
<b>N</b>	mm	1908
<b>O</b>	mm	125
<b>P2</b>	°	37
<b>P3</b>	°	34
<b>R</b>	mm	3779
<b>S</b>	mm	8788
<b>T</b>	mm	4307
<b>U1</b>	mm	2505
<b>U2</b>	mm	2693
<b>V</b>	mm	5592
<b>V1</b>	mm	1285
<b>V2</b>	mm	4009
<b>W</b>	mm	2420
<b>W1</b>	mm	3793
<b>W2</b>	mm	1134
<b>W3</b>	mm	2422
<b>Y</b>	°	12
<b>Z</b>	°	114

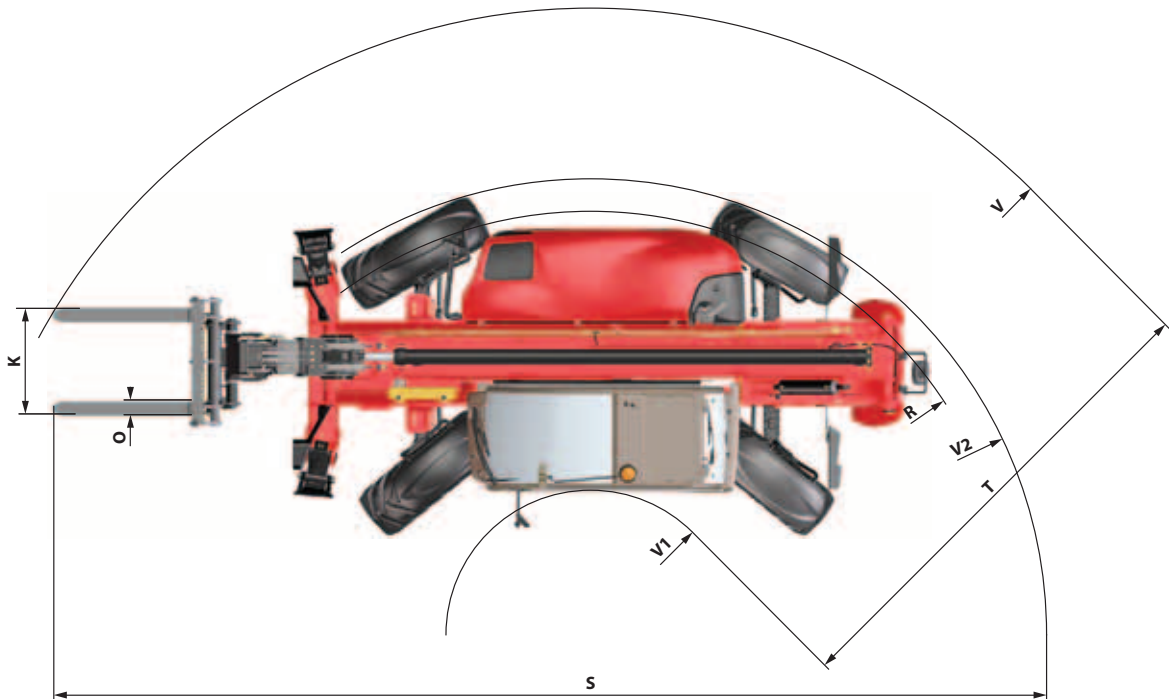
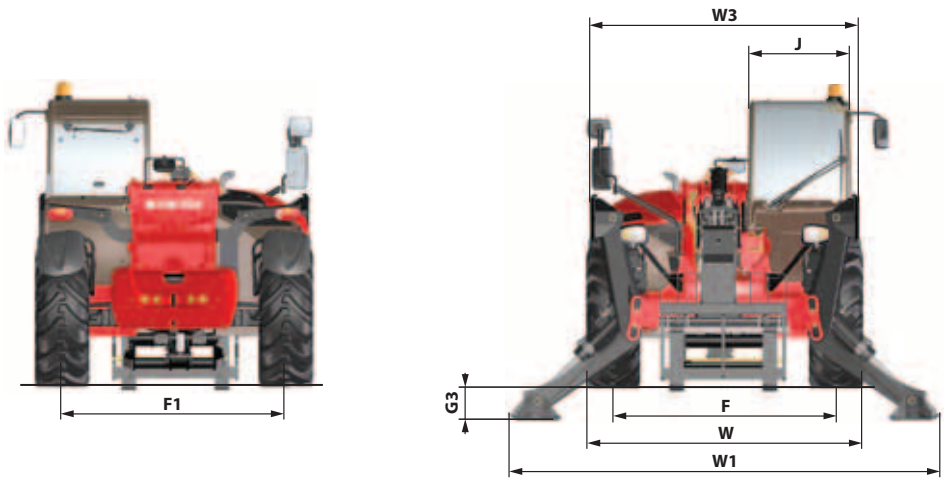
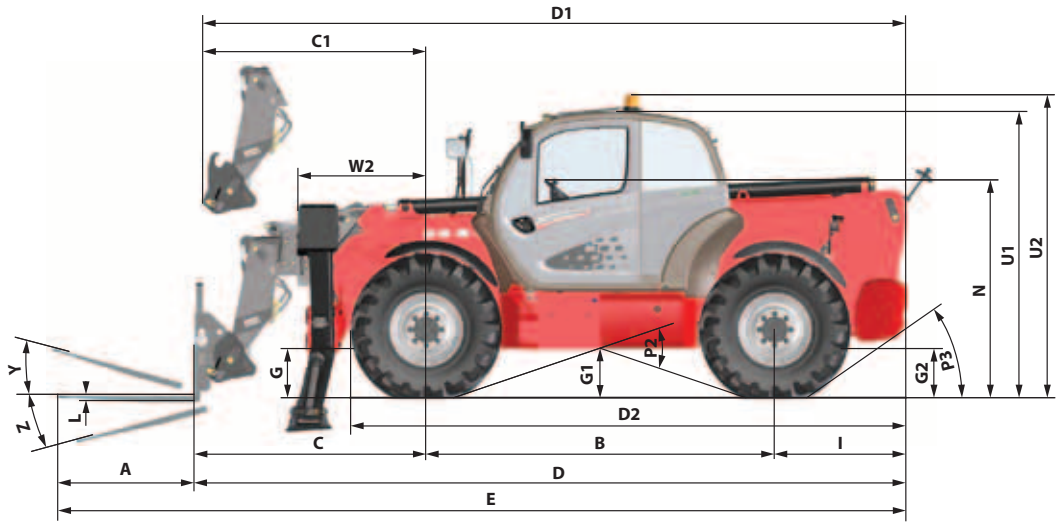



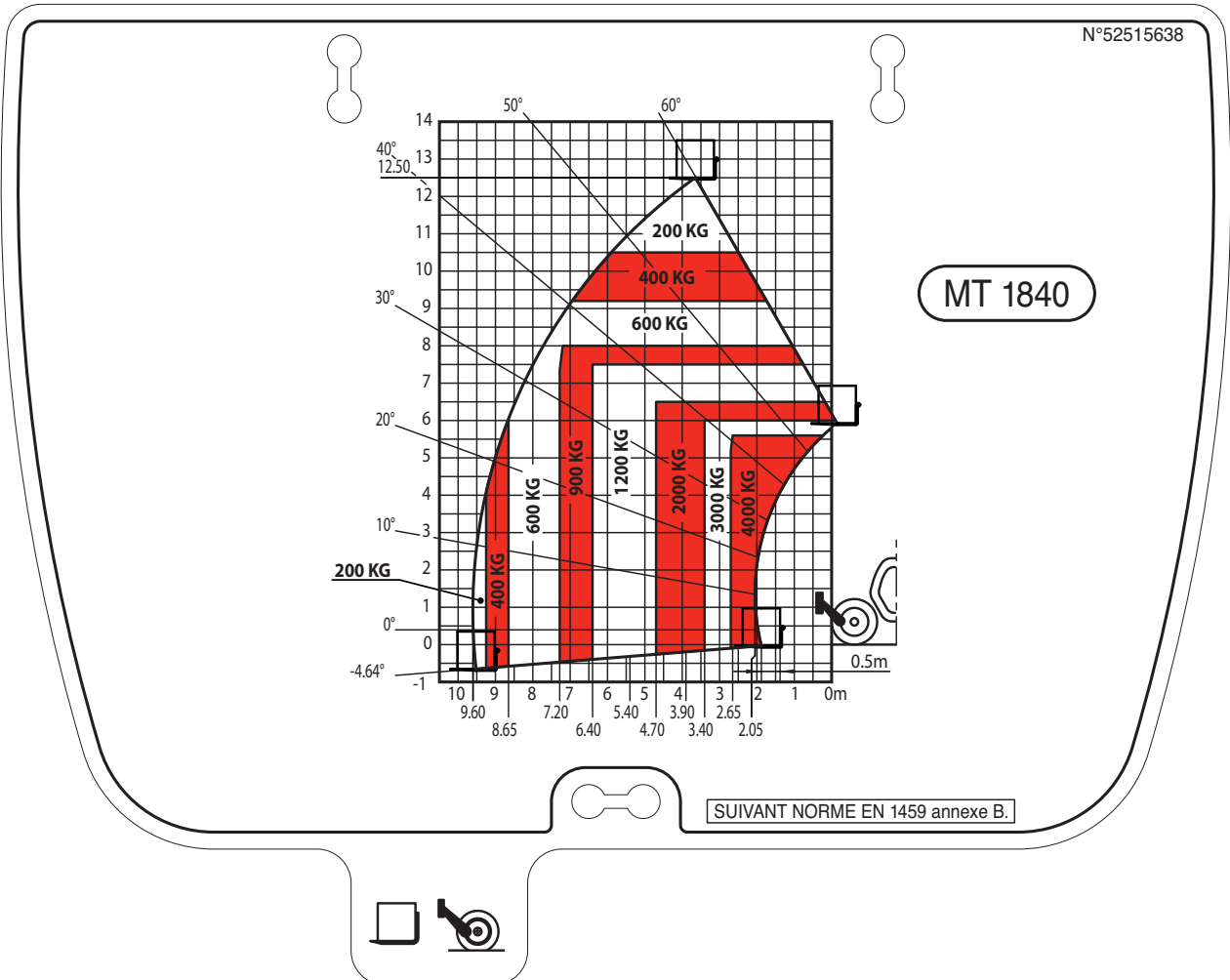
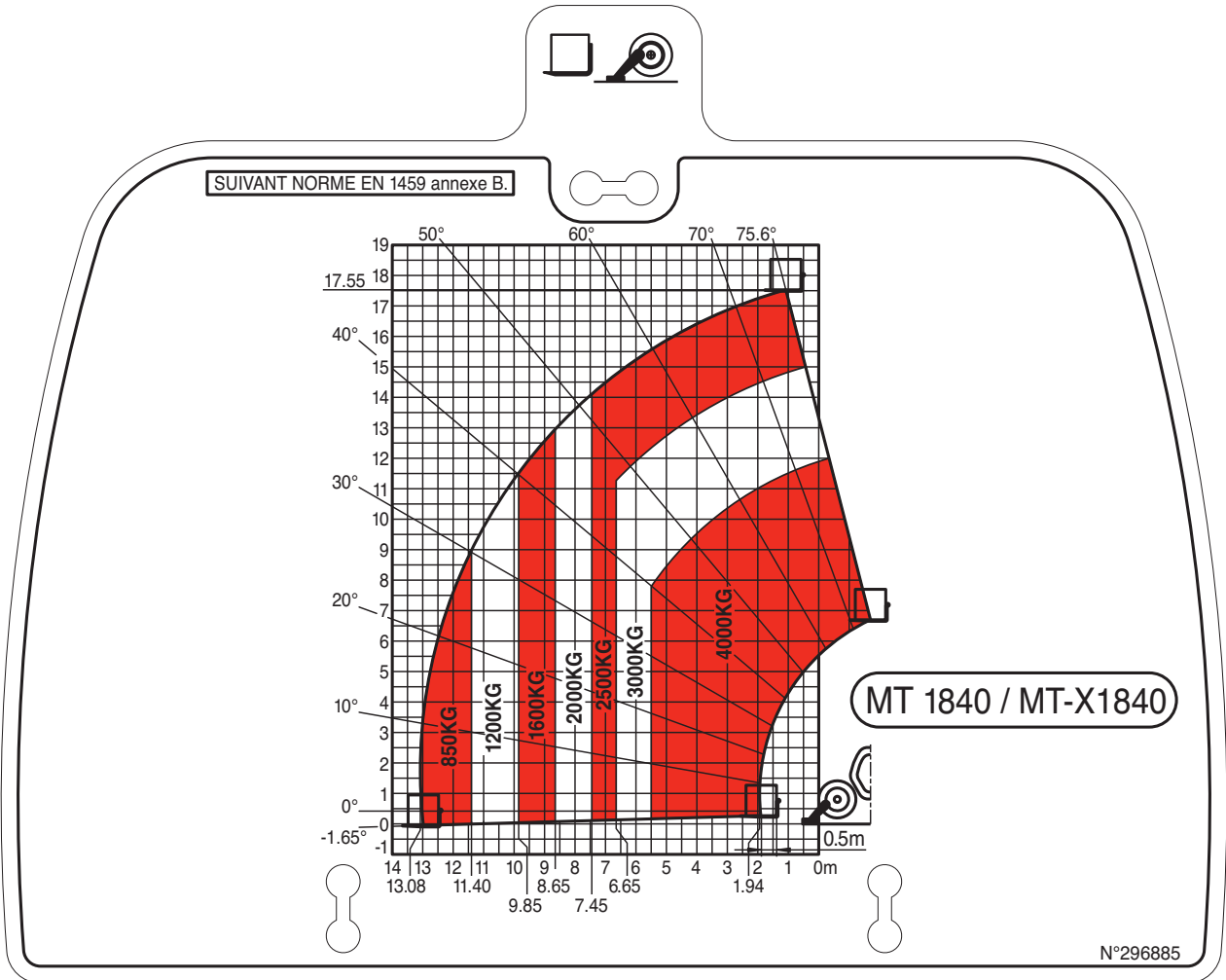

Our lift trucks conform to European standard EN15830 with regard to operator visibility.

- Follow the instructions for optimizing operator visibility of the immediate vicinity (see: 1 - OPERATING AND SAFETY INSTRUCTIONS: INSTRUCTIONS TO THE OPERATOR: DRIVING INSTRUCTIONS UNLADEN AND LADEN: D - VISIBILITY).

## DESCRIPTION AND ADJUSTMENT OF REAR-VIEW MIRRORS

- 1 - LEFT REAR-VIEW MIRROR
- 2 - MAIN RIGHT REAR-VIEW MIRROR
- 3 - CENTRAL RIGHT REAR-VIEW MIRROR
- 4 - UPPER RIGHT REAR-VIEW MIRROR
- 5 - REAR REAR-VIEW MIRROR

- Place the lift truck on level ground with the I.C. engine stopped, and the boom retracted and lowered as far as possible.
- Note the position of the reference points ●...○ in the illustrations, to see and correctly adjust the rear-view mirrors.

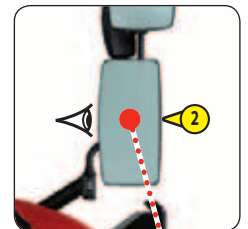
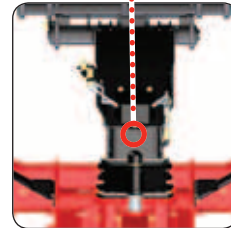
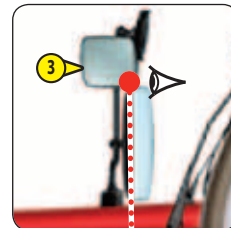
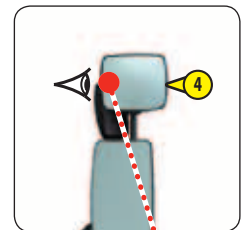
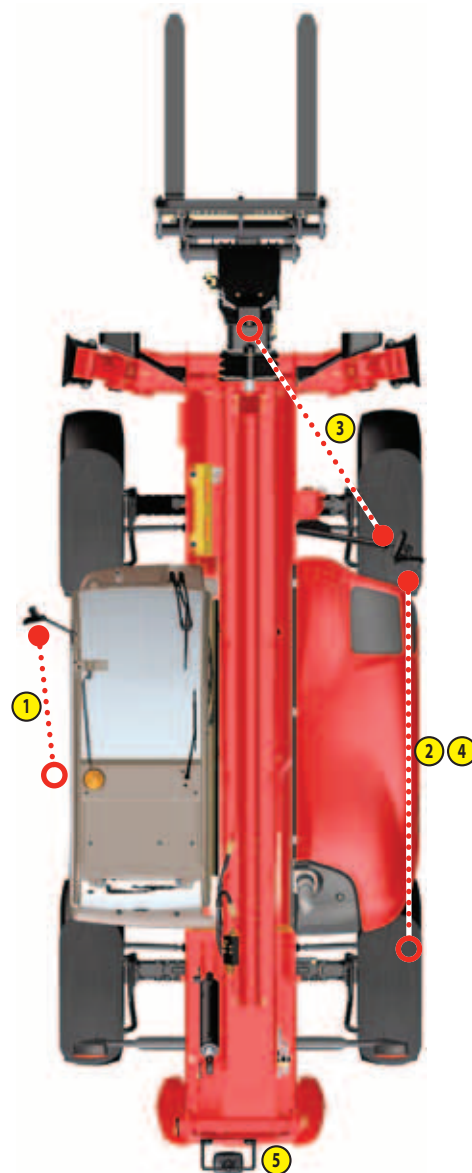
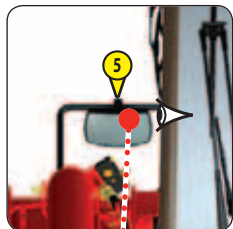
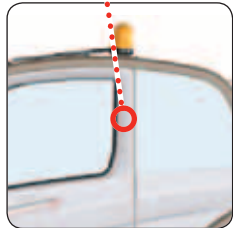
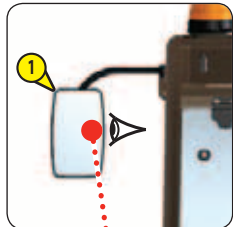
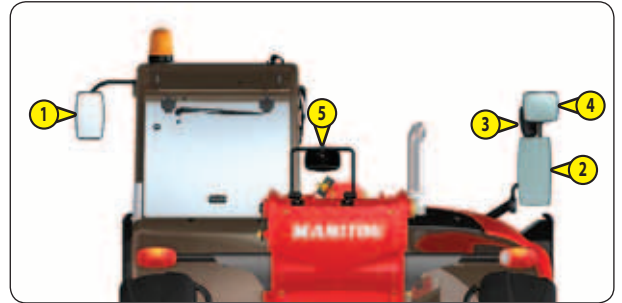

**DIRECT AND/OR INDIRECT VISIBILITY BLIND SPOT ZONES**

In accordance with EN15830, the two diagrams indicate blind spot zones on the visibility test circle (r 12m) and the 1m rectangular zone around the lift truck.

**HANDLING SUSPENDED LOADS**

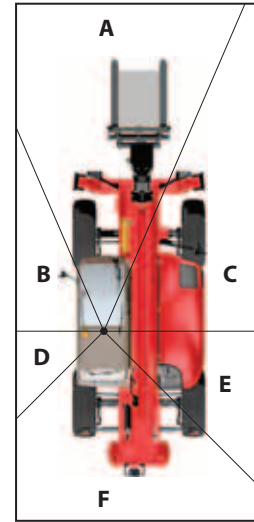
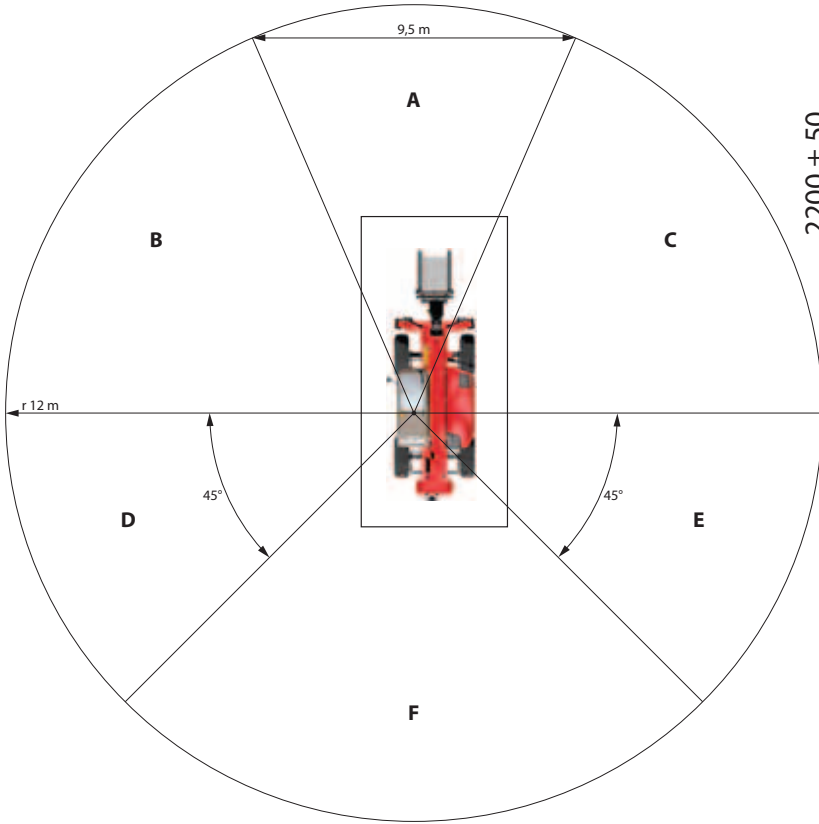

**LOADING THE TRAILER**

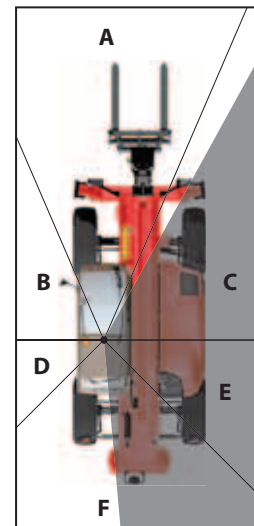
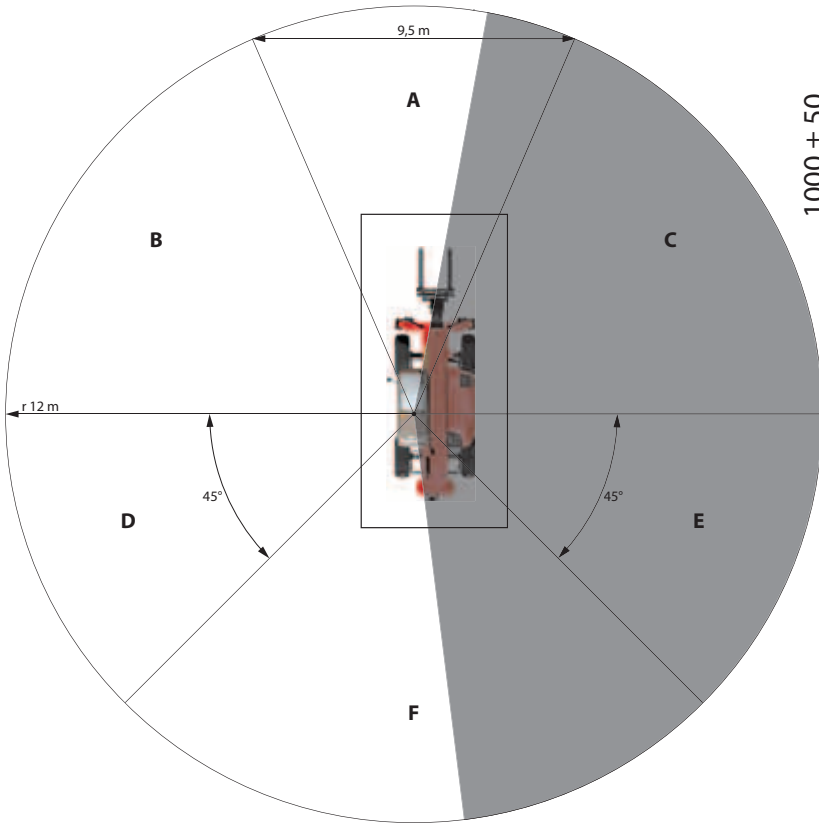

Our lift trucks conform to European standard EN15830 with regard to operator visibility.

- Follow the instructions for optimizing operator visibility of the immediate vicinity (see: 1 - OPERATING AND SAFETY INSTRUCTIONS: INSTRUCTIONS TO THE OPERATOR: DRIVING INSTRUCTIONS UNLADEN AND LADEN: D - VISIBILITY).

## DESCRIPTION AND ADJUSTMENT OF REAR-VIEW MIRRORS

- 1 - LEFT REAR-VIEW MIRROR
- 2 - MAIN RIGHT REAR-VIEW MIRROR
- 3 - CENTRAL RIGHT REAR-VIEW MIRROR
- 4 - UPPER RIGHT REAR-VIEW MIRROR
- 5 - REAR REAR-VIEW MIRROR

- Place the lift truck on level ground with the I.C. engine stopped, and the boom retracted and lowered as far as possible.
- Note the position of the reference points ●...○ in the illustrations, to see and correctly adjust the rear-view mirrors.

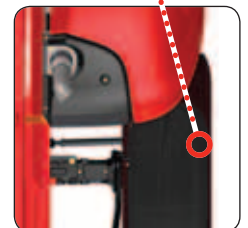
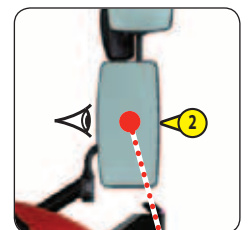
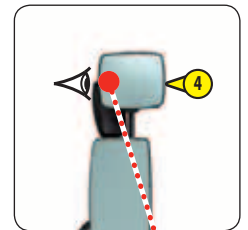
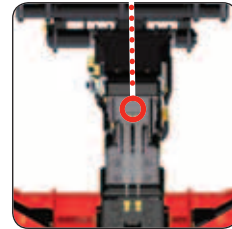
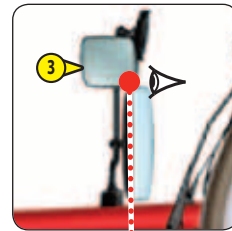
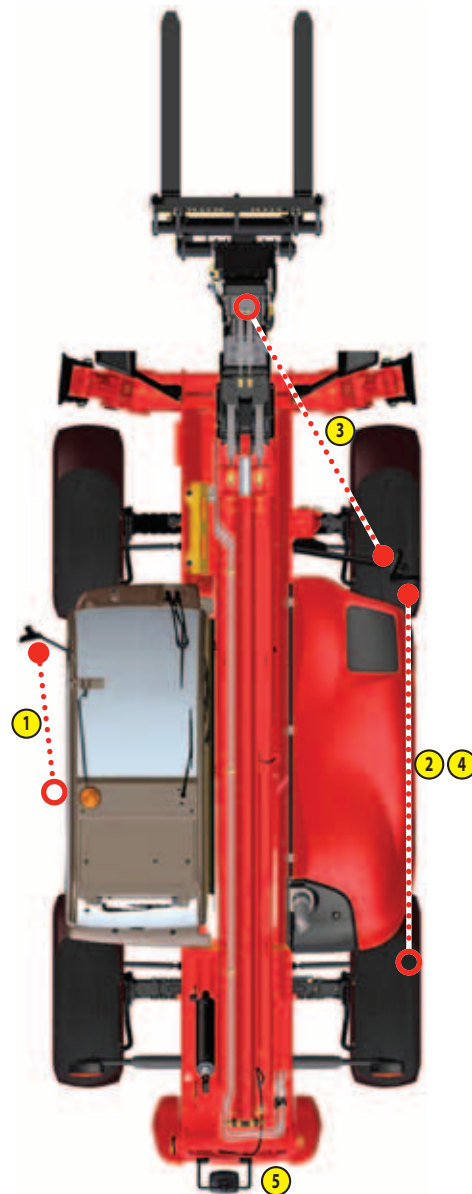
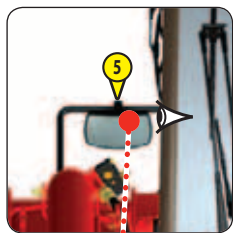
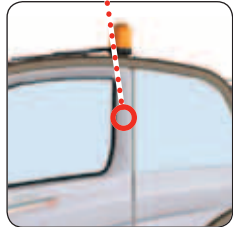
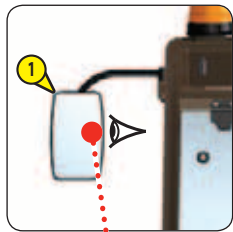
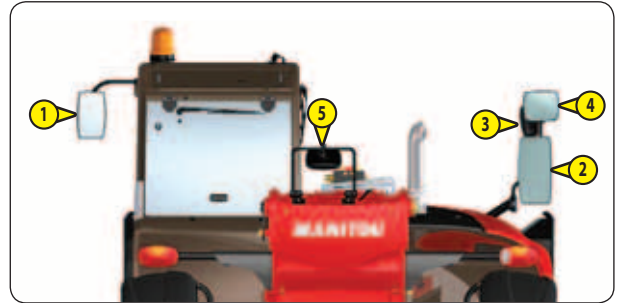

**DIRECT AND/OR INDIRECT VISIBILITY BLIND SPOT ZONES**

In accordance with EN15830, the two diagrams indicate blind spot zones on the visibility test circle (r 12m) and the 1m rectangular zone around the lift truck.

**HANDLING SUSPENDED LOADS**

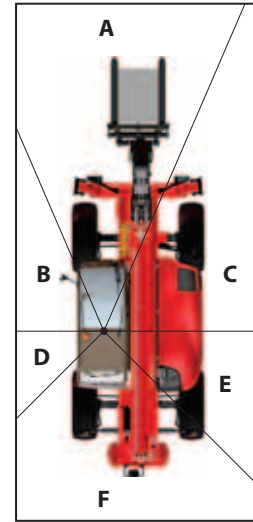
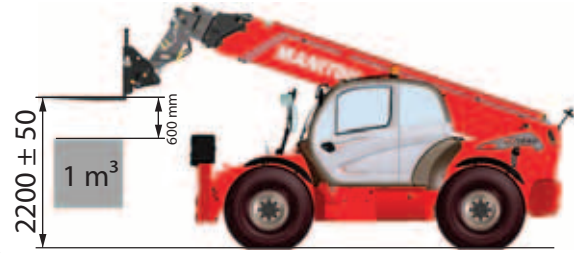
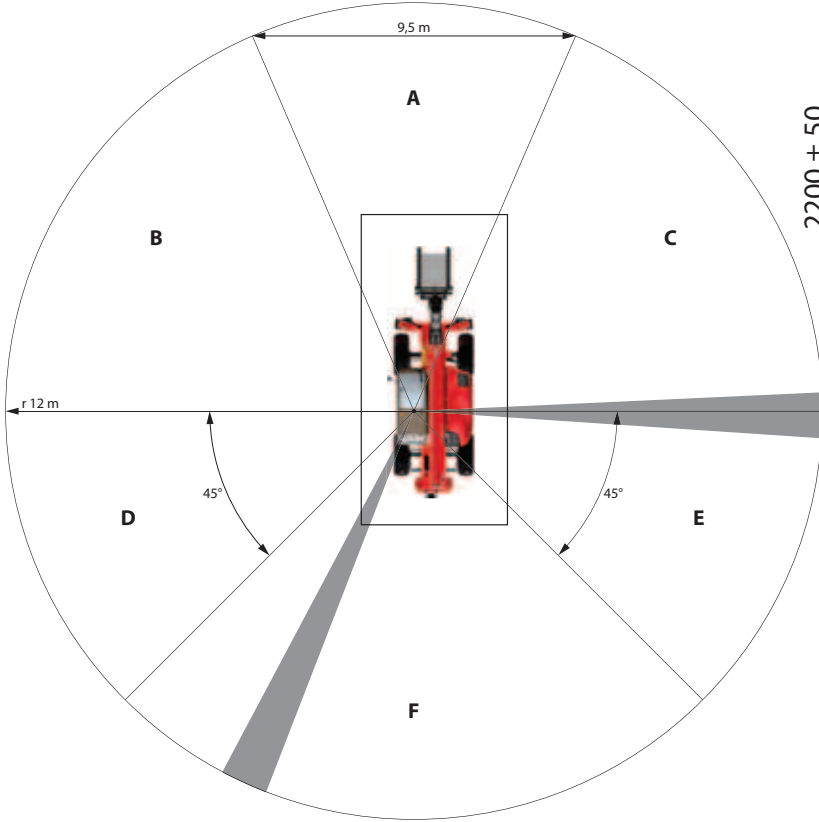

**LOADING THE TRAILER**

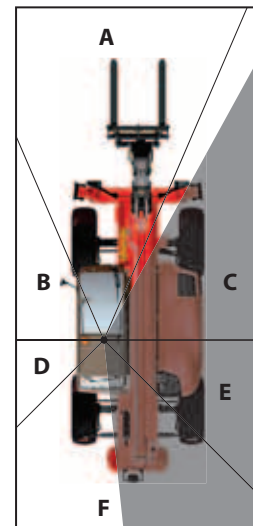
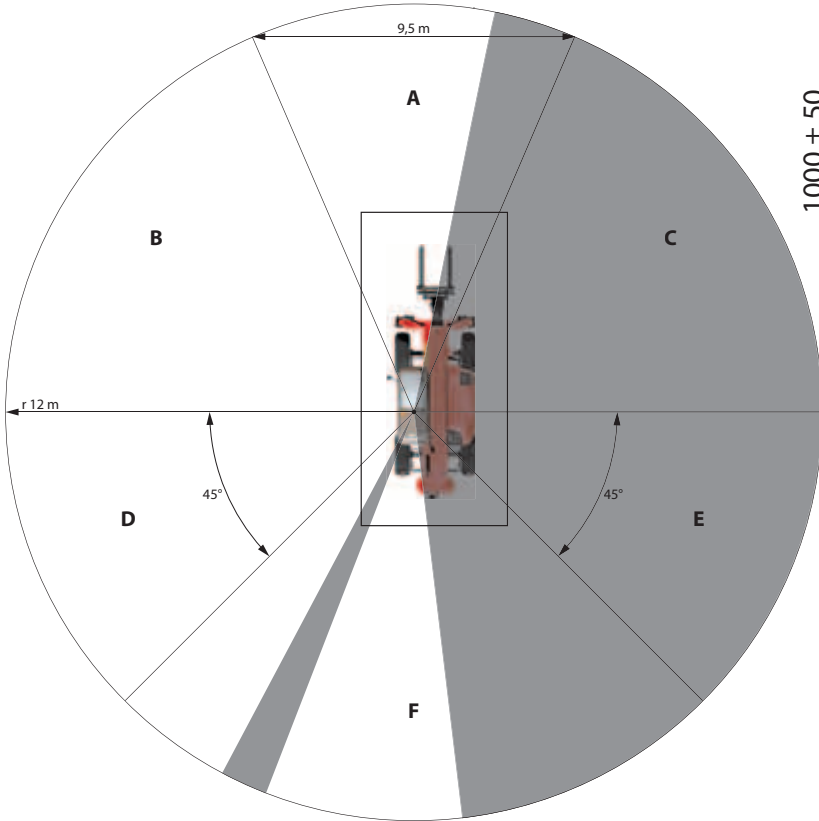

# INSTRUMENTS AND CONTROLS

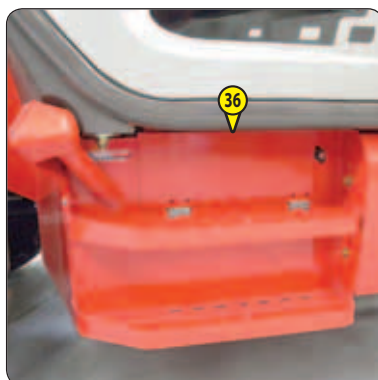
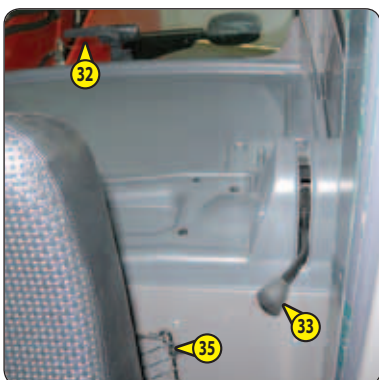
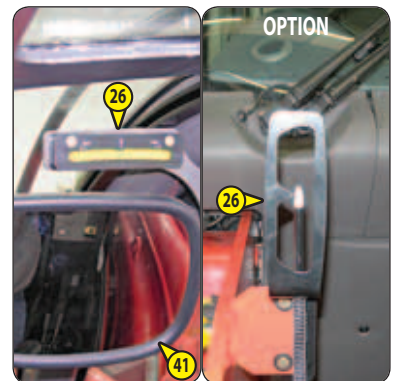
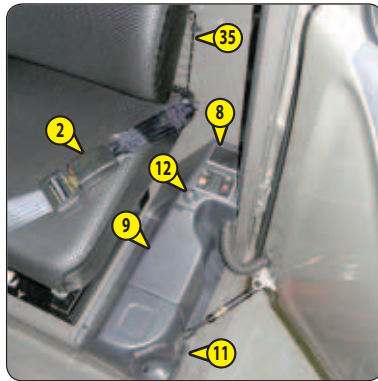
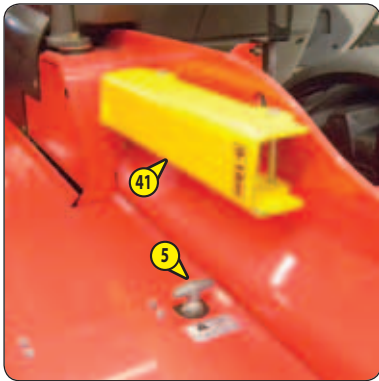
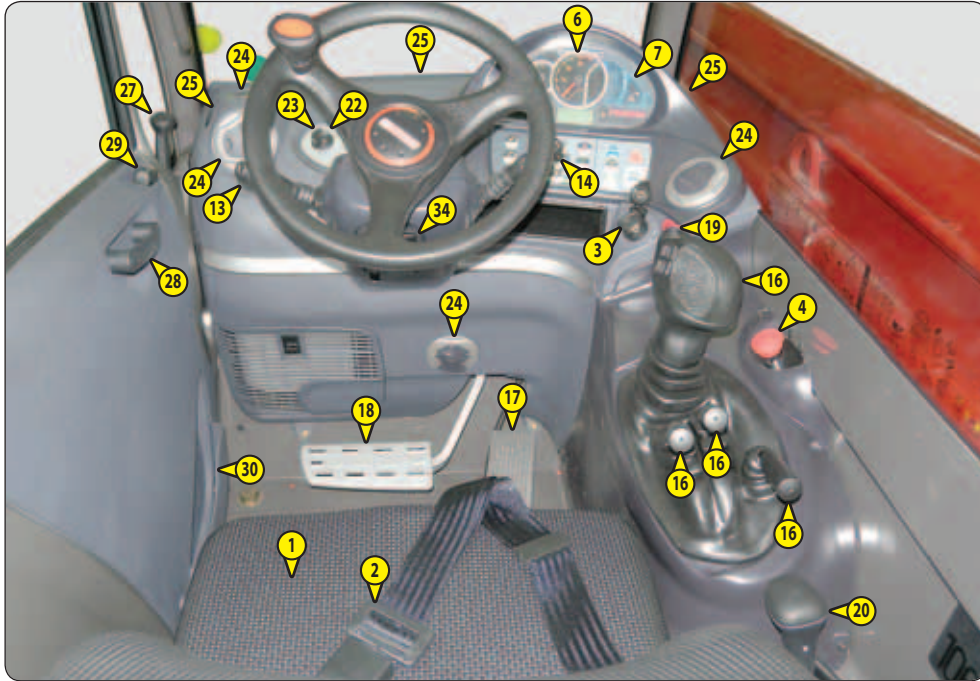

## DESCRIPTION

---

- 1 - DRIVER'S SEAT
- 2 - SEAT BELT
- 3 - IGNITION SWITCH
- 4 - EMERGENCY STOP BUTTON
- 5 - BATTERY CUT-OFF
- 6 - MAN-MACHINE INTERFACE (MMI)
- 7 - LONGITUDINAL STABILITY LIMITER AND WARNING DEVICE
- 8 - SWITCHES
- 9 - FUSES AND RELAYS IN THE CAB
- 10 - FUSES AND RELAYS UNDER THE ENGINE BONNET
- 11 - DOOR PRESENCE SENSORS
- 12 - CIGARETTE LIGHTER
- 13 - LIGHTING, HORN AND INDICATOR SWITCH
- 14 - FRONT AND REAR WINDSCREEN WIPER SWITCH
- 15 - FUNCTION FILES
- 16 - HYDRAULIC CONTROLS
- 17 - ACCELERATOR PEDAL
- 18 - SERVICE BRAKE PEDAL
- 19 - FORWARD/NEUTRAL/REVERSE GEAR SELECTION
- 20 - GEAR LEVER
- 21 - STEERING SELECTION
- 22 - HEATER CONTROL
- 23 - AIR-CONDITIONING CONTROL (AIR-CONDITIONING OPTION)
- 24 - HEATING VENTS
- 25 - DEMIST VENTS
- 26 - LEVEL INDICATORS
- 27 - DOOR OPEN LEVER
- 28 - DOOR CLOSE HANDLE
- 29 - ELECTRIC WINDOW SWITCH
- 30 - SIDE STORAGE SPACE
- 31 - ROOF LIGHT (CAB "COMFORT")
- 32 - HANDLE FOR REAR WINDOW OPENING
- 33 - HANDLE FOR REAR WINDOW CLOSING (CAB "COMFORT")
- 34 - STEERING WHEEL ADJUSTMENT LEVER (OPTION)
- 35 - DOCUMENT STORAGE NET (CAB "COMFORT")
- 36 - STORAGE COMPARTMENT
- 37 - FRONT HEADLIGHTS (NOT ILLUSTRATED)
- 38 - REAR LIGHTS (NOT ILLUSTRATED)
- 39 - ROTATING BEACON LIGHT (NOT ILLUSTRATED)
- 40 - INSIDE REAR-VIEW MIRROR (OPTION)
- 41 - BOOM SAFETY WEDGE

NOTE: All the terms such as: RIGHT, LEFT, FRONT, REAR are as seen by an observer seated on driver's seat and looking straight ahead.

## 1 - DRIVER'S SEAT

### DRIVER'S SEAT (STANDARD)

DESIGNED FOR MAXIMUM COMFORT, THIS SEAT CAN BE ADJUSTED AS FOLLOWS.

#### LONGITUDINAL ADJUSTMENT

- Unlock the locking lever 1.
- Slide the seat to the desired position.
- Release the lever and be sure it returns to the lock position.

#### SEAT HEIGHT ADJUSTMENT

- Sit down correctly in the seat.
- Turn the knob 2 according to the desired height, clockwise to rise, anti-clockwise to lower.

#### SEAT SUSPENSION ADJUSTMENT

- Make sure that the indicator 3 is in the green zone.

#### BACK-REST ANGLE ADJUSTMENT

- Hold the back-rest, push the lever 4 backwards and tilt the back-rest to the desired position.



*If you do not support the back-rest when making adjustments, it swings completely forwards.*

### DRIVER'S SEAT (OPTION)

DESIGNED FOR MAXIMUM COMFORT, THIS SEAT CAN BE ADJUSTED AS FOLLOWS.

#### LONGITUDINAL ADJUSTMENT

- Pull lever 1 upwards.
- Slide the seat to the desired position.
- Release the lever and be sure it returns to the lock position.

#### SEAT CUSHION ADJUSTMENT

The front and the back of the seat cushion can be adjusted separately.

- To adjust the front, push the lever 2 downwards.
- Release it into one of the five possible positions.
- Same procedure to adjust the back by pulling the lever 2 upwards.

#### SEAT SUSPENSION ADJUSTMENT

- Turn the button 3 and adjust according to your weight.

#### BACK-REST ANGLE ADJUSTMENT

- Lean the back against the back-rest.
- Pull the lever 4 and place the back-rest into one of the possible positions.

### DRIVER'S SEAT (OPTION)

DESIGNED FOR MAXIMUM COMFORT, THIS SEAT CAN BE ADJUSTED AS FOLLOWS.

#### WEIGHT ADJUSTMENT (FIG. A)

It is advised that the weight be adjusted when the driver is not sitting in the cab.

- Refer to graduation 1 of the seat.
- Turn handle 2 according to the driver's weight.

NOTE: To avoid any health problems, it is recommended that the weight setting is checked and adjusted before starting the forklift truck.

#### SEAT HEIGHT ADJUSTMENT (FIG. B)

- Raise the seat to the desired position, until you hear the ratchet click. If you raise the seat above the last notch (stop), the seat returns to the lowest position.

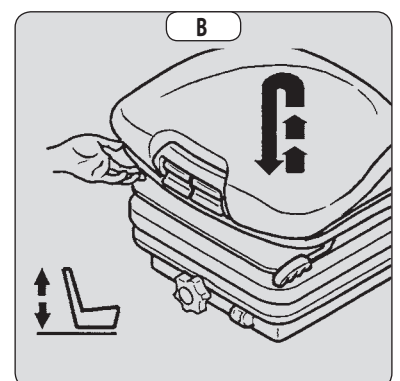
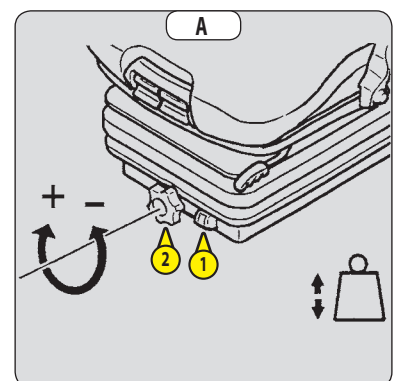



### SEAT BACK-REST ANGLE ADJUSTMENT (FIG. C)

The back-rest angle of the seat may be adjusted to suit the individual.

- Press the left-hand button while pushing on the seat or relaxing pressure on the seat to find a comfortable position.

### SEAT DEPTH ADJUSTMENT (FIG. D)

The depth of the seat may be adjusted to suit the individual.

- Press the right-hand button while raising or lowering the seat to find the desired position.

### EXTENDING THE HEAD-REST (FIG. E)

- The height of the back-rest can be adjusted by pulling it upwards (the notches will click) up to the stop.
- The head-rest can be removed by applying sufficient pressure to pull it off the stop.

### LUMBAR ADJUSTMENT (FIG. F)

This increases the comfort of the seat and the driver's freedom of movement.

- Turn the handle either left or right to adjust the height or depth of the lumbar support.

### ADJUSTMENT OF THE ANGLE OF THE BACK-REST (FIG. G)



*If you do not support the back-rest when making adjustments, it swings completely forwards.*

- Support the back-rest, pull the lever and position the back-rest to find the desired position.

### LONGITUDINAL ADJUSTMENT (FIG. H)

- Adjust the locking lever until you reach the position required. This then locks and the seat will not shift into another position.

### MAINTENANCE (FIG. I)



*A moving backrest increases the risk of an accident!*

Dirt may adversely affect the correct functioning of the seat. For this reason, make sure your seat is always clean.

- To clean or change the cushions, simply remove them from the seat frame.
- Avoid wetting the cushion fabric when cleaning it. Firstly check the resistance of the fabric on a small hidden area before using any fabric or plastic cleaner.

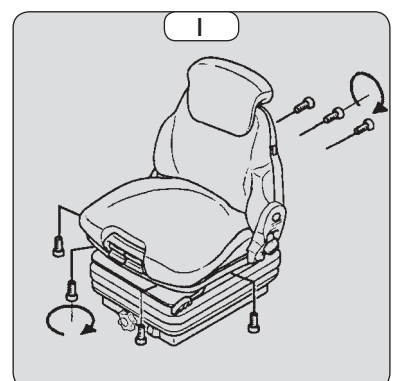
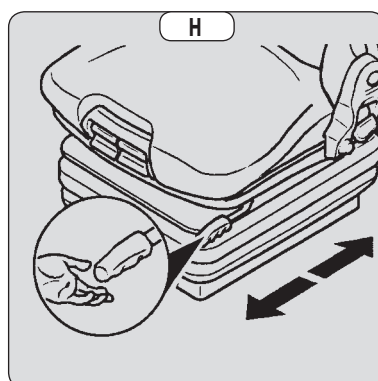
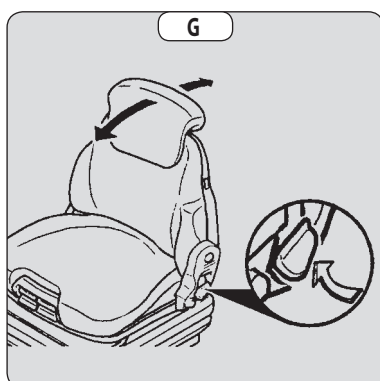
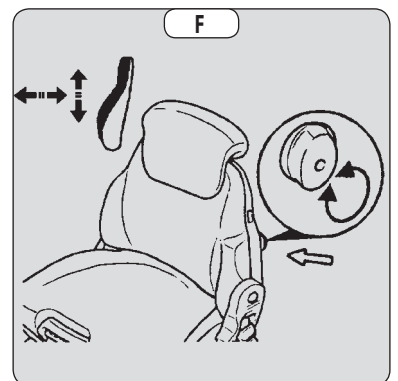
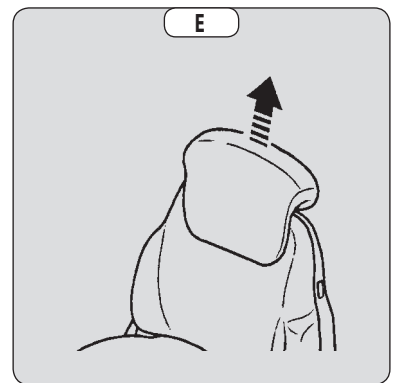
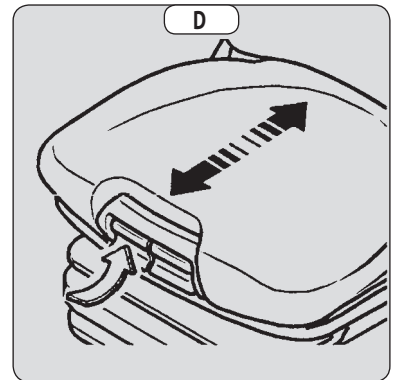
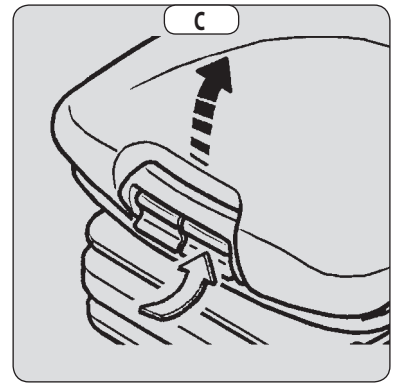

## 2 - SEAT BELT

### ⚠ IMPORTANT ⚠

*In no event should the lift truck be used if the seat belt is defective (fixing, locking, cuts, tears, etc.).  
Repair or replace the seat belt immediately.*

- Sit correctly on the seat.
- Check that seat belt is not twisted.
- Place the seat belt at hip level.
- Attach the seat belt and check that it locks.
- Adjust the seat belt to your body shape without compressing your pelvis and without excessive slack.

## 3 - IGNITION SWITCH

This switch has 5 positions:

- P - Not used.
- O - Ignition switched off and engine stopped.
- I - Ignition + preheat.
- II - Not used.
- III - Start-up and returns to position I as soon as the key is released.

## 4 - EMERGENCY STOP BUTTON

In the event of danger, it enables the engine to be shut down, thereby cutting-off all hydraulic movements.

### ⚠ IMPORTANT ⚠

*Warning, hydraulic movements suddenly stop when using this button.  
Warning, when driving, the lift truck will be brought to a sudden stop if the parking brake is actuated.  
If possible, stop the lift truck before using the emergency stop button.*

- Turn the knob to deactivate it before restarting the lift truck.



## 5 - BATTERY CUT-OFF

For quickly disconnecting the battery when working on the electric circuit or when soldering, for example.

### ⚠ IMPORTANT ⚠

*Operate the battery cut-off no less than 30 seconds after having switched off the ignition with the ignition key.*



## 6 - MAN-MACHINE INTERFACE (MMI)

- 6A - DRIVER PRESENCE
- 6B - INSTRUMENT CONTROL PANEL
- 6C - PANEL FOR BUTTONS AND KEYBOARD
- 6D - SCREEN DISPLAY

UPDATE: In order to gain maximum advantage from the Man-Machine Interface of your forklift truck, contact your dealer to receive the most recent version of the software.



### 6A - DRIVER PRESENCE

The driver's presence is validated when the operator is correctly seated and the cab door is closed.

- It is only after this that the lift truck is operational; the operator can perform hydraulic movements and move the forklift truck.

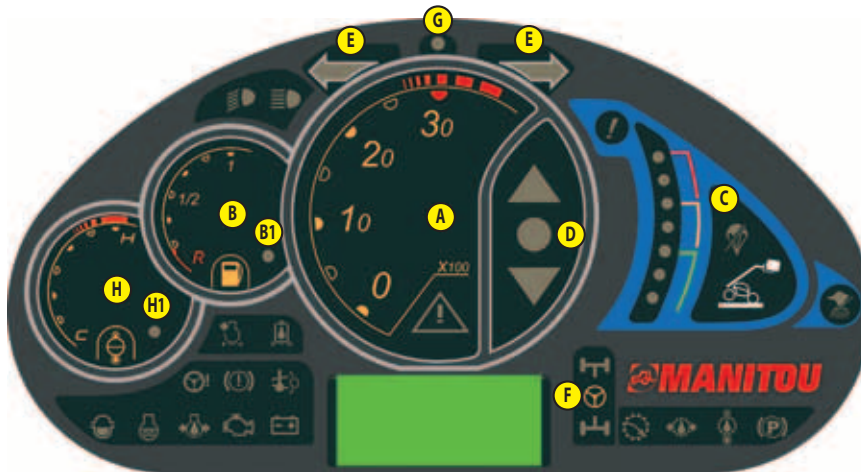

**A - REV COUNTER**

**B - FUEL LEVEL**

When the yellow warning light B1 comes on it means that you are in reserve and that your running time is limited.

**C - LONGITUDINAL STABILITY WARNING LIGHT**

See: 2 - DESCRIPTION: 7 - LONGITUDINAL STABILITY LIMITER AND WARNING DEVICE.

**D - FORWARD/NEUTRAL/REVERSE LIGHT**

See: 2 - DESCRIPTION: 19 - FORWARD/NEUTRAL/REVERSE GEAR SELECTION.

**E - GREEN STEERING LIGHTS**

A continuous beeping sound on and off at the same time as the steering lights when using indicator lights or hazard warning lights.

**F - GREEN WARNING LIGHTS FOR WHEEL ALIGNMENT**

See: 2 - DESCRIPTION: 21 - STEERING SELECTION.

**G - DIGICODE INDICATOR LIGHT**

This light flashes when the digicode is enabled (see: 2 - DESCRIPTION: 6D - SCREEN DISPLAY).

**H - ENGINE WATER LEVEL AND TEMPERATURE LIGHT**

**COLD ENGINE:** If the indicator light H1 comes on when the forklift truck is running, this means that the coolant level is too low. Stop the engine immediately and check the coolant level.

**HOT ENGINE:** If the indicator light H1 comes on when the forklift truck is running, this means that the cooling liquid temperature is too high or its level is too low. Stop the engine immediately and determine the cause of the cooling circuit malfunction.



**MAJOR FAULT WARNING LAMP**

When this light is on it indicates that there is a major fault that may affect the safety for the lift truck or the driver. Stop the lift truck and refer to the error codes (see: 2 - DESCRIPTION: 6D - SCREEN DISPLAY: MENU SCREEN).



**GREEN LIGHT FOR LOW BEAM HEADLIGHTS**



**BLUE LIGHT FOR MAIN BEAM HEADLIGHTS**



**AIR FILTER CLOGGING INDICATOR LAMP**

The light comes on when the air filter cartridge is clogged up. When this light remains continuously lit the cartridge needs changing. Stop the lift truck and carry out the necessary repairs (see: 3 - MAINTENANCE: SERVICING SCHEDULE).



### HYDRAULIC RETURN OIL FILTER CARTRIDGE CLOGGING LAMP

The lamp comes on when the hydraulic return oil filter cartridge is clogged up. When this lamp remains continuously lit the cartridge needs changing. Stop the lift truck and carry out the necessary repairs (see: 3 - MAINTENANCE: SERVICING SCHEDULE).

NOTE: This lamp may light when starting the fork lift truck, it should go off when the hydraulic oil reaches its operating temperature.



### POWER-ASSISTED STEERING FAULT INDICATOR LIGHT

If the lamp comes on when the lift truck is running, stop the engine immediately and determine the cause (possible leak, etc.).



### BRAKE FLUID LEVEL OR POWER-ASSISTED BRAKING FAULT INDICATOR LAMP

If the lamp comes on when the lift truck is running, stop the engine immediately and check the brake fluid level. In the event of an abnormal drop in the level, consult your dealer.



### HIGH EXHAUST GAS TEMPERATURE INDICATOR LAMP (NOT USED)



### WATER IN FUEL PRE-FILTER LAMP

This lamp will come on when there is water in the fuel pre-filter. Stop the lift truck and carry out the necessary repairs (see: 3 - MAINTENANCE: SERVICING SCHEDULE).



### ENGINE AUTOMATIC PREHEAT INDICATOR LAMP

This lamp comes on and should go out as soon as preheating is finished. If it comes on while the lift truck is in operation, immediately stop the engine and determine cause.



### ENGINE OIL PRESSURE INDICATOR LAMP

If the indicator lamp comes on when the forklift truck is running, stop the engine immediately and determine the cause (see oil level in engine crankcase).

NOTE: After starting the engine, the indicator lamp remains lit for a few seconds then goes out when the correct engine oil pressure is reached. The full engine power is then available.



### ENGINE FAULT INDICATOR LAMP

If the lamp comes on when the lift truck is running, stop the engine immediately and determine the cause (possible leak, etc.).

NOTE: This light comes on when the ignition key is in position I and until the engine is started.



### BATTERY LOAD INDICATOR LAMP

If this lamp comes on when the lift truck is running, switch off the engine immediately and check the electric circuit and the alternator belt.



### GREEN "INCHING" MODE PROGRESSIVE TRANSMISSION INDICATOR LAMP (OPTION)

This light comes on when using the "INCHING" mode progressive transmission (see: 2 - DESCRIPTION: 6C - BUTTONS AND KEYBOARD PANEL).



### GEAR BOX OIL PRESSURE LIGHT

This light comes on when there is an abnormal drop in gear box pressure. Stop the forklift truck and look for the cause (e.g., Low oil level in the gearbox, internal leak in the gearbox, etc.).



### GEAR BOX OIL TEMPERATURE LIGHT

This light comes on when the temperature of the gear box oil is abnormally high. In this case, place the forward/reverse selector in neutral and leave the engine to idle for a few minutes. If the light remains on, stop the forklift truck and contact your dealer.

NOTE: Abnormal heating of the oil may be linked to incorrect use of the gear box ratios (see: 2 - DESCRIPTION: 20 - GEAR LEVER).



### PARKING BRAKE INDICATOR LAMP

This indicator lamp comes on when the parking brake is applied.

A flashing light indicates a fault (see: 2 - DESCRIPTION: 6D - SCREEN DISPLAY: MENU SCREEN).



### HYDRAULIC MOVEMENT NEUTRALISATION LIGHT

The light comes on when the hydraulic controls are neutralized and when a prohibited hydraulic movement is requested.

NOTE: When driving on the road, it is strongly recommended that you lock all hydraulic movements.

### 6C - BUTTONS AND KEYBOARD PANEL



A beep is sounded each time one of the buttons is pressed.



"BUCKET" MODE (NOT USED)



"INCHING" MODE PROGRESSIVE TRANSMISSION (NOT USED)



"SUSPENDED LOAD" MODE

See: 2 - DESCRIPTION: 7 - LONGITUDINAL STABILITY LIMITER AND WARNING DEVICE.



## ATTACHMENT CIRCUIT (OPTION)

### ⚠ IMPORTANT ⚠

*By default, the attachment circuit in continuous mode is disabled as soon as the operator leaves the cab.  
This condition can be changed from the OPT menu on the menu screen.*



ATTACHMENT CIRCUIT UNLOCKED (by default)



ATTACHMENT CIRCUIT LOCKED

• It is recommended to use this function when the lift truck is not fitted with hydraulic attachment.



ATTACHMENT CIRCUIT IN CONTINUOUS MODE

• The indicator lamp will light when it is in use.

The operating screen displays the enabled mode. Press the or button to display the other available mode(s).

NOTE: On stabilisers, the display in zone 2 on the operating screen switches to zone 7.

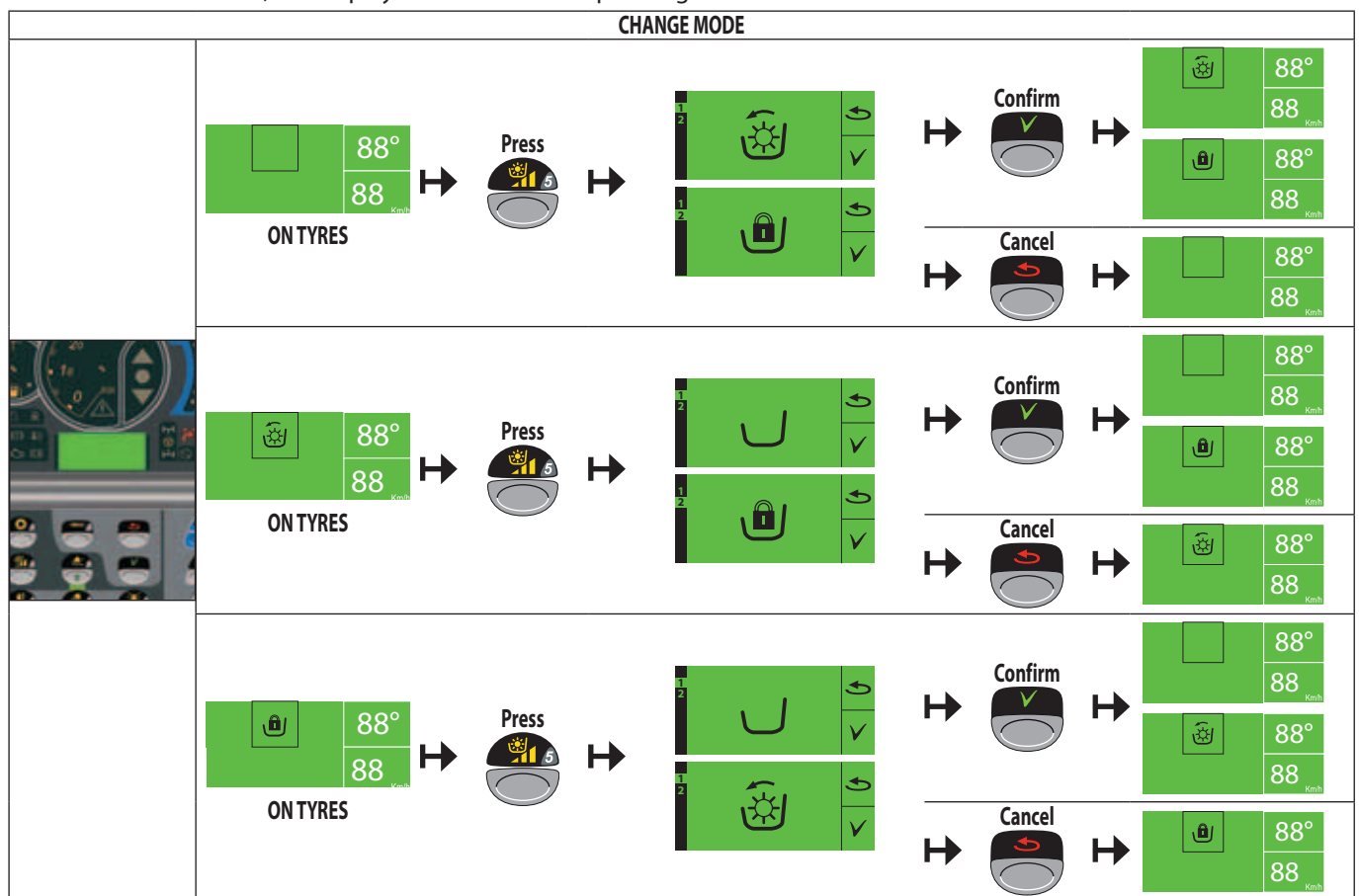

### ADJUSTING THE ATTACHMENT CIRCUIT HYDRAULIC FLOW RATE IN CONTINUOUS MODE

- The pictogram flashes, and switches to the setting screen as soon as hydraulic flow rate is selected using button A on the attachment hydraulic control.
- Button A forward for positive percentage (+ XX %), backward for negative percentage (XX %).
- Hold button A in the same position for 4 seconds to confirm the chosen hydraulic flow rate
- Press the button, or activate button A, to return to the screen with the flashing pictogram and thus disable continuous mode.





### BOOM SUSPENSION (NOT AVAILABLE)



### ATTACHMENT EASY HYDRAULIC CONNECTION (OPTION)

For easy connection and disconnection of hydraulic attachments.



- Press for two seconds on the push-button to release the attachment circuit hydraulic pressure. Screens



and  will be displayed alternately.

- Connect or disconnect the rapid connectors of the hydraulic attachment (see: 4 - OPTIONAL ATTACHMENTS FOR USE WITH THE RANGE: PICKING UP THE ATTACHMENTS).



### REAR FOG LIGHT

Only works when the low beam or main beam lights are switched on. The indicator will light when in use.



### FRONT WORKING LIGHTS (OPTION)



### ROTATING BEACON LIGHT

NOTE: Except in case of emergency, disabling the rotating beacon light is recommended when the ignition is switched off to avoid a flat battery.



### MENU SCREEN DISPLAY

A flashing light indicates a fault (see: 2 - DESCRIPTION: 6D - SCREEN DISPLAY: MENU SCREEN).



### CANCEL OR BACK



### VALIDATION



### TESTING THE LONGITUDINAL STABILITY LIMITER AND WARNING DEVICE

See: 2 - DESCRIPTION: 7 - LONGITUDINAL STABILITY LIMITER AND WARNING DEVICE.



### FAN REVERSAL (NOT AVAILABLE)



### MANUAL PARKING BRAKE

The manual or automatic (by default) parking brake can be configured from the OPT menu in the menu screen.



### HAZARD WARNING LIGHTS

Enables the L.H. and R.H. Indicators to be switched on simultaneously, with the ignition off.

NOTE: Except in case of emergency, disabling the hazard warning lights is recommended when the ignition is switched off to avoid a flat battery.



## LOCKING HYDRAULIC CONTROLS



HYDRAULIC CONTROLS AVAILABL (by default)



TILTING LOCKED



HYDRAULIC CONTROLS LOCKED

• When driving on the road, it is strongly recommended that you lock all hydraulic movements.

Press the or button to display the other available mode(s), the first screen displayed is the opposite of the enabled mode.

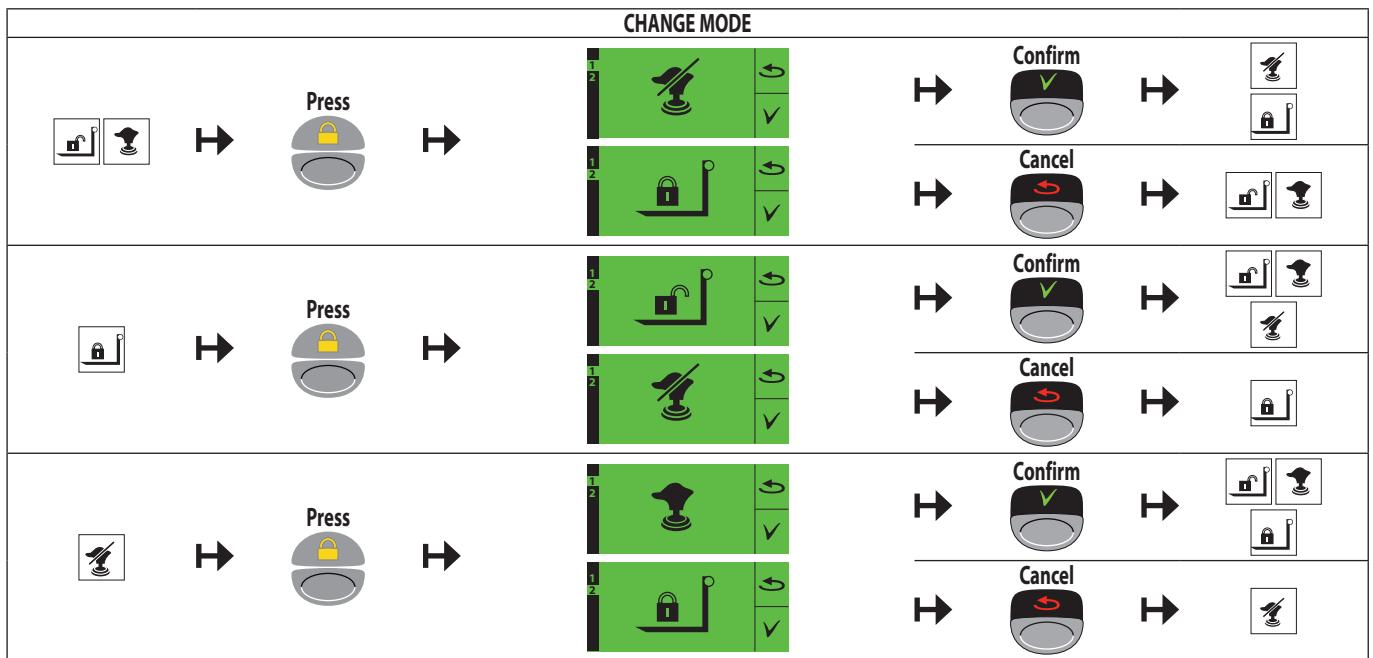

## 6D - SCREEN DISPLAY



### SCREEN OFF

Lift truck parked, with ignition off and without the driver.



### LOGO SCREEN

System initialising. A beep is sounded when this screen appears. If the screen remains permanently displayed, contact your dealer.



### DIGICODE SCREEN

The digicode is disabled by default. It can be enabled from the OPT menu on the menu screen. A beep is sounded when this screen appears.

- Switch on the forklift truck ignition. Enter the code (default 0000) using the keys on the keyboard and confirm with the confirm button

NOTE: The code can be changed in the OPT menu in the menu screen.





### HOUR METER SCREEN

With the operator present in the cab and the electrical contact cut, the screen displays the total number of hours worked [888888h], the number of hours for the day [888.88h] and the number of hours before the next major maintenance [888h].

#### RESETTING THE DAILY WORKING HOURS COUNTER BACK TO ZERO

- Reset the daily hour counter to zero from the XPRT menu in the menu screen.

NOTE: Authorisation of this function can be configured from the OPT menu in the menu screen.

#### RESETTING THE MAINTENANCE COUNTER TO 500H





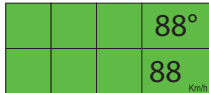





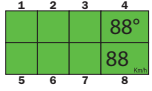







- Reset the maintenance counter to 500h from the XPRT menu in the menu screen.











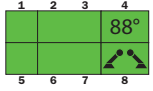





NOTE: The operational screen can be displayed as required using the button .



### OPERATING SCREEN

The screen displays the lift truck's operating state (different screen for each operating mode).

		FORKLIFT TRUCK ON TYRES
1		Blank screen.
		If no function is unlocked and at least one function is locked (see fault screen).
		If at least one function is unlocked (see fault screen).
2		Blank screen.
		Attachment circuit unlocked.
		Flashing screen. Attachment circuit in requested continuous mode disabled.
		Steady screen. Attachment circuit in continuous mode enabled.
3		Blank screen.
4		Boom lifting angle in degrees.
		Lifting angle sensor fault (contact your dealer).
5		Blank screen.
		Maintenance key.
6		Blank screen.
7		Blank screen.
		Transmission locked in neutral, driver presence not validated.
8		Lift truck speed in km/h.
		Lift truck speed sensor fault (contact your dealer).

		FORKLIFT TRUCK ON STABILISERS	
1		Blank screen	
		If no function is unlocked and at least one function is locked (see fault screen).	
		If at least one function is unlocked (see fault screen).	
2/3		Blank screen.	
4		Boom lifting angle in degrees.	
		Lifting angle sensor fault (contact your dealer).	
5		Blank screen.	
		Maintenance key.	
6		Blank screen.	
7		Blank screen.	
		Attachment circuit unlocked.	
		Flashing screen. Attachment circuit in requested continuous mode disabled.	
		Steady screen. Attachment circuit in continuous mode enabled.	
8		Stabilizers resting on the ground and under pressure.	To validate the information, the last movement of the stabilizer must be lowering.
		Left stabilizer resting on the ground and under pressure.	
		Right stabilizer resting on the ground and under pressure.	



## HELP SCREEN

One of these screens appears to inform the operator of the operations to be performed in the current configuration. The appearance of this screen generates an audible beep.

	Necessary maintenance (see: 3 - MAINTENANCE: D - EVERY 500 HOURS' OPERATION).
	Time to next maintenance in hours (see: 3 - MAINTENANCE: D - EVERY 500 HOURS' OPERATION).
	Close the door and press the accelerator pedal.
	Press the accelerator pedal.
	Retract and/or lower the boom to raise the stabilisers.
	Raise the stabilisers and/or lower the boom before correcting the tilt.
	Lower the boom.
	Using the attachment circuit in continuous mode and indicating the hydraulic capacity.
	Reset the forward/reverse selector via neutral.
	Overspeed, reduce speed. or Transmission fault, the visual  is triggered simultaneously (contact your dealer).
	Put down the stabilisers.
	Boom chain tension fault.



## LOCKING SCREEN



*In any event, stop the lift truck and contact your dealer.*

By default, the operator is not permitted to unlock the functions (see: 2 - DESCRIPTION: 6D - SCREEN DISPLAY: MENU SCREEN).

One of these screens appears when the system detects an operating defect on the forklift truck. A beep is sounded when this screen appears.

These defects cause certain functions to be prohibited in order to ensure safety. However it is possible for the operator and his responsibility (and/or that of the person in charge of the establishment) to override the prohibition in order to secure the parking of the forklift truck (e.g. unlocking the hydraulic distributor fault in order to retract and lower the boom).

Unlocking is activated temporarily; the function will lock again as soon as the engine is switched off.



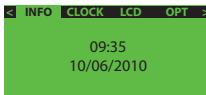

### UNLOCKING THE FUNCTION

- Move the triangles using the button to the open padlock and confirm with the button .

	Driver presence.
	Transmission fault.
	Retracting stabilizer.
	Tilt.
	Telescoping boom.
	Hydraulic distributor.



## MENU SCREEN

- Press the button  to display the menu screen with the time and date. Navigate horizontally between menus using the buttons   and vertically in the sub-menus using the buttons  .

### INFO

- Time and date (by default).
- Forklift truck in failsoft mode and/or fault detected (see table of error codes).  
MC: Active defaults in the Man-Machine interface electronic control unit.  
MP1: Active faults in the MP1 electronic control unit  
MP2: Active faults in the MP2 electronic control unit.  
ENG: Active faults in the engine.
- “Check Maintenance” appears for several seconds if maintenance is necessary.

### CLOCK

- HOUR: Change the hour.
- DATE: Change the date.
- FORM: Change the time or date format.

### LCD

- BACKL: Backlight.
- CONTR: Contrast.

### OPT

The contents of this menu can be accessed by means of a customer password.

- RST H: Resetting of daily hour counter to zero, permitted (by default) or not permitted.
- PARK: Manual parking brake or automatic (by default).
- CFLOW: Forced operation without driver presence, permitted (by default) or not permitted.
- LLMC: Disabling of aggravating hydraulic movement cut-off permitted (by default) or not permitted.
- PASS: Fault override permitted (by default) or not permitted.
- UNIT: Speed of travel displayed in MPH or Km/h (by default).
- DIGI1: Digicode enabled (by default) or not enabled.
- DIGI2: Change the 4 figure digicode (lift truck start-up).
- CUST: Change the customer code.

### DIAG

The contents of this menu enable your dealer to perform diagnostics on the Man-Machine Interface.

### XPRT

- RESET > HOURM: Reset the day counter to zero.  
MAINT: Reset the maintenance frequency to 500 hours.
- ADMIN > ADMIN: Change the administrator code.
- CALIB > SECU: Calibration of boom angle and strain gauge.  
GAUGE: Resetting of the strain gauge.  
BOOM: Boom angle calibration.

## 7 - LONGITUDINAL STABILITY LIMITER AND WARNING DEVICE

### ⚠ IMPORTANT ⚠

The operator must respect the lift truck's load chart, and the operating mode according to the attachment.

This device warns the operator of the lift truck's longitudinal stability limits. However, lateral stability can reduce the load chart in the upper part, and this reduction is not detected by the device.

Depending on the type of work required, the longitudinal stability limiter and warning device allows the operator to operate the lift truck in complete safety.



### IDENTIFICATION OF YOUR SETTINGS

<b>CONFIGURATION 1</b>	Warning light A9 is off when driving.
<b>CONFIGURATION 2</b>	Warning light A9 is lit when driving.
<b>CONFIGURATION 3</b>	Press "BUCKET" MODE button  , the warning light goes out after three seconds.

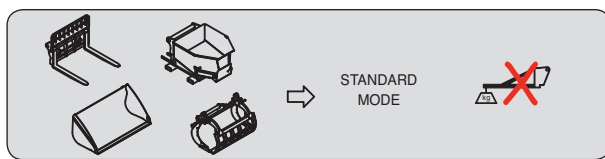

### "HANDLING" MODE

USE ON FORKS

#### CONFIGURATION 1

- By default, the device is in "HANDLING MODE" each time the lift truck is started.
- Protection against forward tip-over when making aggravating movements is ensured, except when the telescopic boom is retracted.

DEVICE STATUS			
HALTED	SLOW SPEED 1 to 3 km/h	SPEED > 3 km/h	TELESCOPE(S) IN RETRACTED POSITION
A4-A5: Very slow intermittent sound alarm. A6: Slow intermittent sound alarm. A7: Fast intermittent sound alarm. A8: Very fast intermittent sound alarm.		-No sound alarm.	-No sound alarm.

#### CONFIGURATION 2

- By default, the device is in "HANDLING MODE" each time the lift truck is started.
- Protection against forward tip-over when making aggravating movements is ensured, except when the telescopic boom is retracted and/or the lift truck is moving.

DEVICE STATUS			
HALTED	SLOW SPEED 1 to 5 km/h	SPEED > 5 km/h	TELESCOPE(S) IN RETRACTED POSITION
A4-A5: Very slow intermittent sound alarm. A6: Slow intermittent sound alarm. A7: Fast intermittent sound alarm. A8: Very fast intermittent sound alarm.	A7: Fast intermittent sound alarm. A8: Very fast intermittent sound alarm. -Warning light A9 lit.	-No sound alarm. -Warning light A9 lit.	-No sound alarm.  -Warning light A9 lit.

#### CONFIGURATION 3

- By default, the device is in "HANDLING MODE" each time the lift truck is started.
- Protection against forward tip-over when making aggravating movements is ensured, except when the telescopic boom is retracted.

DEVICE STATUS			
HALTED	SLOW SPEED 1 to 5 km/h	SPEED > 5 km/h	TELESCOPE(S) IN RETRACTED POSITION
A4-A5: Very slow intermittent sound alarm. A6: Slow intermittent sound alarm. A7: Fast intermittent sound alarm. A8: Very fast intermittent sound alarm.	A7: Fast intermittent sound alarm. A8: Very fast intermittent sound alarm.	-No sound alarm.	-No sound alarm.  -Warning light A9 lit.

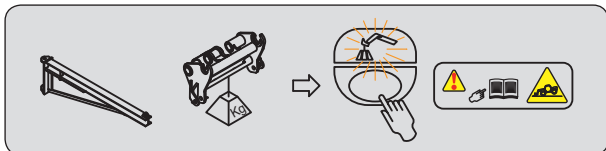

**"SUSPENDED LOAD" MODE**

USE WITH HOIST (offering a higher safety margin)

- Place the lift truck in the transport position.
- Press the  button, the "SUSPENDED LOAD" MODE is confirmed by a beep and the lighting of the indicator lamp. Hydraulic tilting movements are disabled, as well as the lifting movement when the longitudinal stability limit is reached (indicator lamp A8 lit).
- Press this button again or switch off the ignition with the ignition key to return to "HANDLING" MODE.
- Protection against forward tip-over when making aggravating movements is ensured, except when the telescopic boom is retracted.

**CONFIGURATION 1**

DEVICE STATUS			
HALTED	SLOW SPEED 1 to 3 km/h	SPEED > 3 km/h	TELESCOPE(S) IN RETRACTED POSITION
A4-A5: Very slow intermittent sound alarm. A6: Slow intermittent sound alarm. A7: Fast intermittent sound alarm. A8: Very fast intermittent sound alarm.		-No sound alarm.	-No sound alarm.

**CONFIGURATION 2 and 3**

DEVICE STATUS			
HALTED	SLOW SPEED 1 to 5 km/h	SPEED > 5 km/h	TELESCOPE(S) IN RETRACTED POSITION
	A4-A5: Very slow intermittent sound alarm. A6: Slow intermittent sound alarm. A7: Fast intermittent sound alarm. A8: Very fast intermittent sound alarm.		-No sound alarm.  -Warning light A9 lit.

## A - VISUAL ALARMS

- A1 - A2 - A3: There is a significant reserve of longitudinal stability.
- A4 - A5: The lift truck is approaching the limit of longitudinal stability, move with care.
- A6: The lift truck is close to the limit for longitudinal stability. Drive carefully.
- A7: The lift truck is very close to the limit of longitudinal stability. Manoeuvre with extreme caution.
- A8: The lift truck is at the authorised limit of longitudinal stability.



## B - HYDRAULIC MOVEMENT CUT-OFF

### "HANDLING" MODE

- A8: All "AGGRAVATING" hydraulic movements are cut-off. Only perform de-aggravating hydraulic movements in the following order: retract and raise the boom.

### "SUSPENDED LOAD" MODE

- A8: All "AGGRAVATING" and boom raising hydraulic movements are cut off. Only the boom retraction hydraulic movement is available.

## C - DISABLING "AGGRAVATING" HYDRAULIC MOVEMENT CUT-OFF



*Remain very vigilant during this operation. The only information available to the operator is the lift truck's dynamic stability.*

Authorization of this function can be configured from the OPT menu in the menu screen.

In certain cases, in order to get out of a difficult situation, the operator can bypass this safety system. Button C temporarily disables the cut-off of "AGGRAVATING" hydraulic movements.

- Hold down button C, indicator lamps A9 and C1 lamp will light (60 second time delay), and at the same time perform the necessary "AGGRAVATING" hydraulic movement with extreme care.



## D- TESTING THE LONGITUDINAL STABILITY LIMITER AND WARNING DEVICE



- Short press the  button to verify at any time that the longitudinal stability alarm is working.
- Correct operation: All the LEDs A1 to A8 light for two seconds and an audible signal is sounded.

NOTE: This test does not check the proper adjustment of the longitudinal stability limiter, which must be inspected daily or after every 10 hours of service (see: 3 - MAINTENANCE: A - DAILY OR EVERY 10 HOURS OF OPERATION).

## E - STRAIN GAUGE



*Disassembly or calibration of the strain gauge is prohibited, this must only be done by specially trained personnel, consult your dealer.*

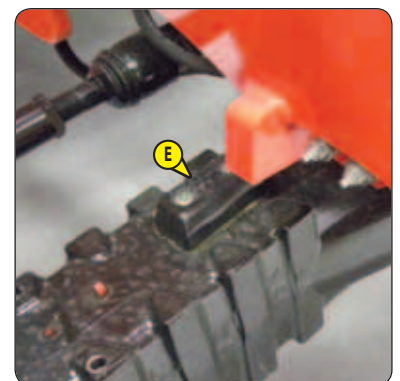

Page voluntarily blank.

## 8 - SWITCHES

### A - REAR WORKING LIGHTS (OPTION)

### B - WORKING LIGHTS ON BOOM (OPTION)

### C - ROOF WINDSCREEN WIPER AND WASHER

In the high position this switch makes it possible to turn on the windscreen wiper, and when maintained in the low position, to turn on the windscreen washer.

### D - SIDE WINDSCREEN WIPER AND WASHER

In the high position this switch makes it possible to turn on the windscreen wiper, and when maintained in the low position, to turn on the windscreen washer.

### E - REAR WINDSCREEN DEFROST (OPTION)

### F - OPTION

### G - ELECTRICAL PREDISPOSITION ON THE BOOM (OPTION) MT 1435/1440 ...

### H - DUAL EFFECT REAR HYDRAULIC PREDISPOSITION (OPTION)

See: 2 - DESCRIPTION: DESCRIPTION AND USE OF THE OPTIONS.

### I - REAR WORK LIGHTS OPTION

### J - OPTION

### K - OPTION

### L - DISABLING CUT-OFF OF AGGRAVATING HYDRAULIC MOVEMENTS

See: 2 - DESCRIPTION: 7 - LONGITUDINAL STABILITY LIMITER AND WARNING DEVICE.

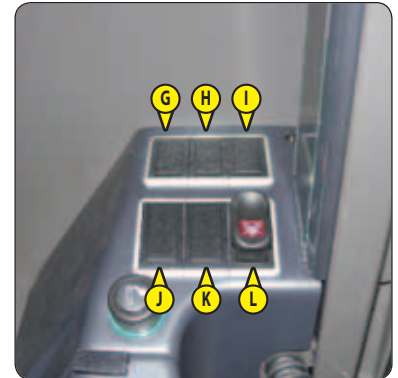

## 9 - FUSES AND RELAYS IN THE CAB

A sticker on the inside of the access panel provides a quick indication of the use of the fuse plate's components described below.

- Remove access panel 1 to access the fuses and relays. Replace a used fuse with a new fuse of the same quality and capacity. Never reuse a repaired fuse.

### RELAYS

- K1 - OPTION.
- K2 - Front windscreen wiper intermittent operation relay.
- K3 - OPTION Air conditioning fan relay.
- K4 - OPTION.
- K5 - OPTION Ventilation/heating relay.
- K6 - OPTION Air conditioning compressor control relay.

### MINIFUSE

- F1 - OPTION (3A).
- F2 - OPTION Rear hydraulic predisposition (7,5 A).
- F3 - OPTION.
- F4 - Ventilation/heating (2A).
- F5 - Disabling of the "AGGRAVATING" hydraulic movement cut-off (2A).
- F6 - OPTION Electrical predisposition on boom head (5A).
- F7 - OPTION Anti-start (2A).
- F8 - OPTION Pneumatic seat (15A).
- F9 - Ignition (2A).
- F10 - OPTION Car radio (2A).
- F11 - Cigarette lighter (10A).
- F12 - Front windscreen wiper and washer + intermittent operation relay K2 (15A).



F46		F40		F30	25A	F20	20A	F10	2A		
F45	30A	F39		F29	3A	F19	7.5A	F9	2A		
F44	40A	F38	OPT 3A	F28	5A	F18	15A maxi	F8	15A		
F43	50A	F37	OPT 15A	F27	15A	F17	15A	F7	2A		
F42	40A	F36	2A	F26	7.5A	F16	15A 25A 15A maxi	F6	OPT 15A maxi		
F41		F35	2A	F25	2A 7.5A	F15	15A	F5	2A		
		F34	2A	F24	15A	F14	K1 15A maxi	F4	2A		
		F33	5A	F23	2A	F13	10A	F3	15A maxi		
		F32	7.5A	F22	3A	F12	15A	F2	OPT 7.5A		
		F31	5A	F21	3A	F11	10A	F1	OPT 3A		
N° 52551322											
										K3	K6
										K2	K5
										K1	K4
											OPT



- F13 - Rear windscreen wiper and washer (10A).
- F14 - OPTION Relay K1.
- F15 - OPTION.
- F16 - OPTION Working lights on boom (15A).
- F17 - OPTION Rear working lights (15A).
- F18 - OPTION Rear window de-icing (15A).
- F19 - Roof windscreen wiper and washer (7,5A).
- F20 - Window winder (20A).
- F21 - Roof light + door switch + seat switch (3A).
- F22 - Man-Machine Interface (MMI) (3A).
- F23 - OPTION (2A).
- F24 - Front windscreen wiper motor (15A).
- F25 - OPTION Anti-start (2A or 7,5A).
- F26 - OPTION Car radio (7,5A).
- F27 - Rear, roof and side windscreen wiper motors (15A).
- F28 - Diagnostic plug (5A).
- F29 - OPTION Air conditioning compressor control relay K6 (7,5A).
- F30 - Ventilation/heating (20A).
- F31 - Engine electronic control unit alert (5A).
- F32 - Side windscreen wiper and washer (7,5A).
- F33 - Diagnostic plug (5A).
- F34 - OPTION.
- F35 - OPTION.
- F36 - OPTION.
- F37 - OPTION.
- F38 - Free.
- F39 - Free.
- F40 - Free.

#### MAXIFUSE

- F41 - Free.
- F42 - Electronic box MP2 (40A).
- F43 - Ignition switch (50A).
- F44 - Electronic box MP1 (40A).
- F45 - OPTION Air conditioning relays K3 and K12 (30A).
- F46 - Free.

### 10 - FUSES AND RELAYS UNDER THE ENGINE BONNET

- Open engine bonnet 1 in order to gain access to the fuses and relays. Replace a used fuse with a new fuse of the same quality and capacity. Never reuse a repaired fuse.

#### RELAYS

- K21 - Engine preheating relay.
- K23 - Diesel pump relay.

#### MAXIFUSE

- F51 - Free.
- F52 - K21 relay (60A).
- F53 - Engine ECU power supply relay (30A).

#### MINIFUSE

- F54 - Engine diagnostic plug power supply (5A).
- F55 - K23 relay (20A).
- F56 - Free.
- F57 - Free.
- F58 - Free.
- F59 - Free.

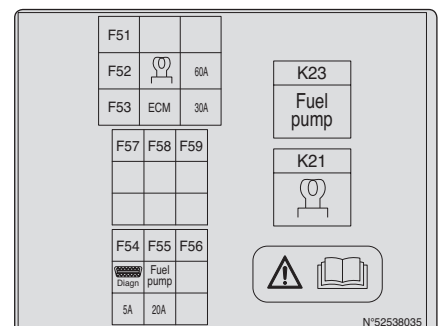

## 11 - DOOR PRESENCE SENSORS

See: 2 - DESCRIPTION: 6 - MAN-MACHINE INTERFACE (MMI).

## 12 - CIGARETTE LIGHTER

## 13 - LIGHTING, HORN AND INDICATOR SWITCH

The switch controls the visual and sound alarms.

- A - All lights are off, the indicator lights do not flash.
- B - The right hand indicator lights flash.
- C - The left hand indicator lights flash.
- D - Sidelights and rear lights on.
- E - The dipped headlights and the rear lights are on.
- F - The main beam headlights and the rear lights are on.
- G - Headlights signal.

Pressing the end of the switch sounds the horn.

NOTE: Positions D - E - F - G can be used without switching on the ignition.

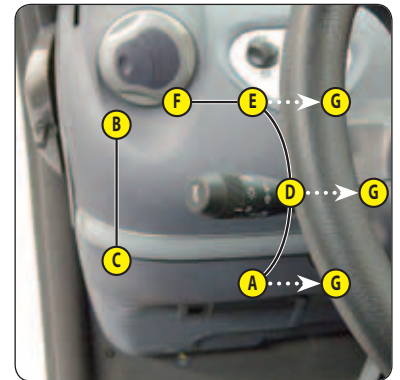

## 14 - FRONT AND REAR WINDSCREEN WIPER SWITCH

FRONT WINDSCREEN WIPER

- A - Front windscreen wiper stop.
- B - Front windscreen wiper low speed.
- C - Front windscreen wiper high speed.
- D - Front windscreen wiper intermittent control.
- E - Front windscreen washer, pulse-driven.

REAR WINDSCREEN WIPER

- F - Rear windscreen wiper stop.
- G - Rear windscreen wiper.
- H - Rear windscreen washer, pulse-driven.

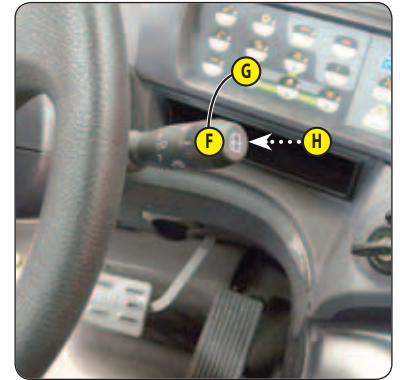
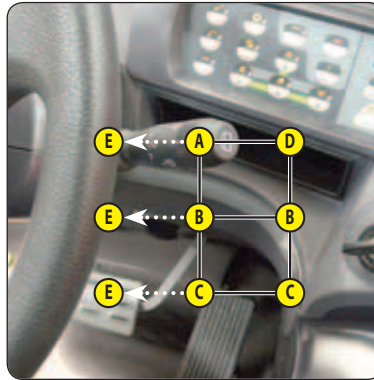

## 15 - FUNCTION FILES

These files contain the description of the hydraulic controls and the load charts for the attachments used on the lift truck.

## 16 - HYDRAULIC CONTROLS

Authorization for using the hydraulic controls is given by the validation of the driver's presence (see: 2 - DESCRIPTION: 6 - MAN-MACHINE INTERFACE (MMI)) and if the conditions of use for the hydraulic control are followed.

### ⚠ IMPORTANT ⚠

*Do not attempt to alter the hydraulic system pressure. In the event of malfunction, contact your dealer.  
ANY ALTERATION MAY RENDER THE WARRANTY NULL AND VOID.*

*Operate the hydraulic controls gently and smoothly to avoid accidents caused by jerking of the lift truck.*

- A - Lifting and tilting control lever.
- B - Telescoping control button.
- C - Left stabiliser control lever.
- D - Right stabiliser control lever.
- E - Levelling corrector control lever.
- F - Attachment control button.

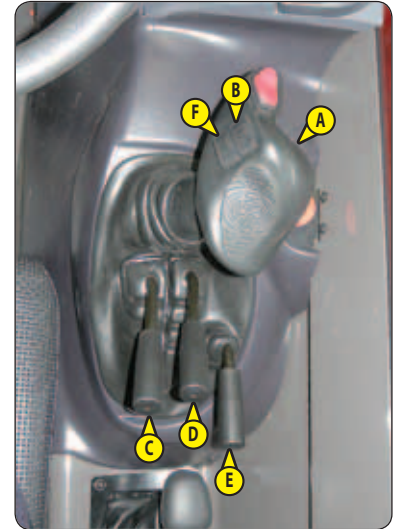

### LIFTING THE LOAD

- The lever A backwards when lifting.
- The lever A forwards when lowering.

### TILT OF CARRIAGE

- The lever A to the left for reverse tilt.
- The lever A to the right for forward tilt.

### TELESCOPING

- Button B forwards for extending.
- Button B backwards for retracting.

NOTE: When completely retracting the telescopes, insistently operate the control so as to allow all the telescopes to retract fully.

NOTE: MT 1840 ...

Complete extension of the telescopes can only be carried out if the stabilisers are lowered and exercising pressure on the ground.

### L.H. STABILISER

- Move lever C forwards to lower.
- Move lever C backwards to lift.

### R.H. STABILISER

- Move lever D forwards for lowering.
- Move lever D backwards for lifting.

NOTE: The stabilisers can only be raised if the telescopes are retracted and the lifting angle of the boom is less than 62°.

### LEVELING CORRECTOR (OPTION)

- Move lever E to the left to tilt the lift truck to the left.
- Move lever E to the right to tilt the lift truck to the right.

NOTE: The tilt correction may only be performed if the lifting angle for the boom is less than 30°.

### ATTACHMENT (OPTION)

- Button F forwards or backwards.

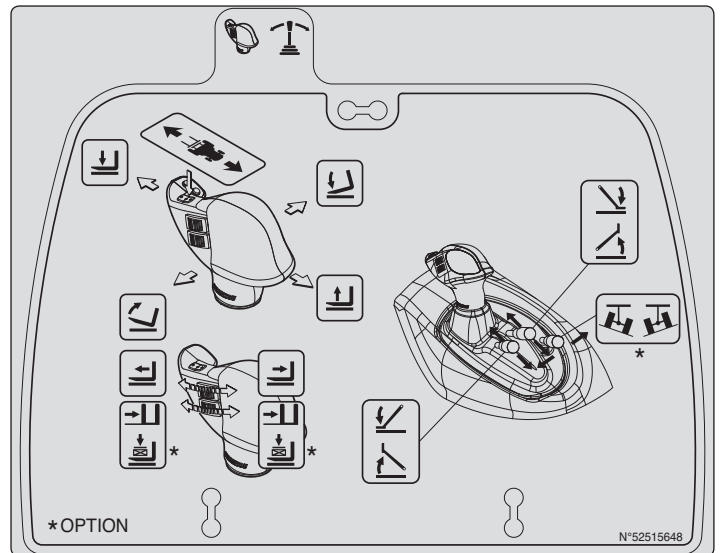

## 17 - ACCELERATOR PEDAL

## 18 - SERVICE BRAKE PEDAL

The pedal acts on the front and rear wheels by a power assisted hydraulic brake system, and allows the lift truck to be slowed down and stopped.

## 19 - FORWARD/NEUTRAL/REVERSE GEAR SELECTION

Authorisation to use the gear selector is given by validation of driver presence (see: 2 - DESCRIPTION: 6 - MAN-MACHINE-INTERFACE MMI).

When changing the direction of travel, the lift truck should be traveling at slow speed and not accelerating.

- FORWARD GEAR: Push the switch forward (position A), the indicator light A1 will flash and then remain steady when you press the accelerator pedal.
- REVERSE: Push the switch backward (position B), the indicator light B1 will flash then remain steady when you press the accelerator pedal. Reversing lights and an acoustic reversing alarm indicate that the forklift truck is reversing.
- NEUTRAL: Set the switch to the centre position (position C), the indicator light C1 will come on and the handbrake is applied (by default).

NOTE: An indicator light that flashes while the forklift truck is in use indicates a fault (see: 2 - DESCRIPTION: 6D - SCREEN DISPLAY: MENU SCREEN).

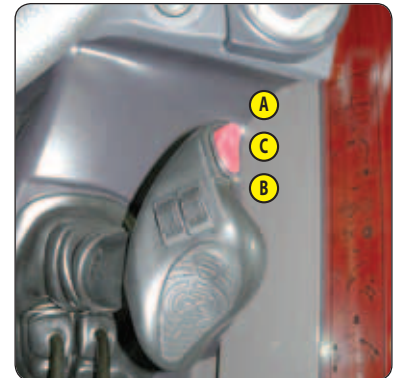

## 20 - GEAR LEVER

In order to change gear, it is necessary to cut the transmission by pressing button 1 on the lever.

- 1st gear: To the left, backwards.
- 2nd gear: To the left, forwards.
- 3rd gear: To the right, backwards.
- 4th gear: To the right, forwards.

### CONDITION FOR USING THE TRANSMISSION GEAR RATIOS

NOTE: On these forklift trucks with a torque converter, it is not necessary to start automatically in 1st gear and progress up the gears.

#### **⚠ IMPORTANT ⚠**

*The gearbox ratio selection should be made carefully depending on the work to be performed.*

*A poor choice may result in the extremely rapid rise of the gearbox oil temperature through excessive slipping of the converter, which could lead to serious damage (it is essential to stop and change the working conditions if the gearbox oil temperature indicator lamp comes on).*

*This poor choice may also result in the forklift truck's performance deteriorating in forward gear. When the forward force increases, the forward speed in the r ratio (for example, in 3rd gear) may be lower than the forward speed that could be obtained with the r-1 gear (in 2nd instead of 3rd).*

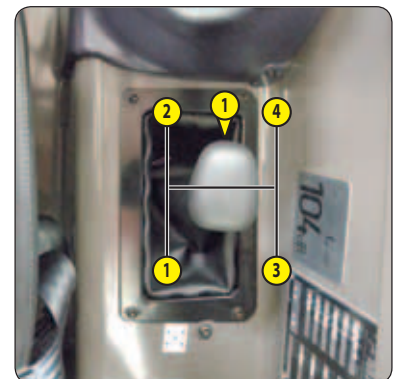

In general, we would advise you to use the following gears according to the nature of the work being carried out.

- On the road: Set off in 3rd gear and change up to 4th if the conditions and state of the road permit it. In mountainous areas, set off in 2nd gear and change up to 3rd if the conditions and state of the road permit it.
- With a trailer on the road: Set off in 2nd gear and move to 3rd if the conditions and state of the road permit it.
- Handling: 3rd gear.  
2nd gear in narrow spaces.
- Earth moving: 1st gear.
- Loading (reclaiming with bucket, manure fork, etc.): 2nd gear.

## 21 - STEERING SELECTION

### A - GREEN WHEEL ALIGNMENT INDICATOR LIGHTS

#### ⚠ IMPORTANT ⚠

*Before selecting one of the three possible steering positions, bring all 4 wheels into alignment with the lift truck axis.  
Never change the steering mode whilst driving.*

These green lamps come on to indicate the alignment of the wheels in relation to the lift truck. The A1 indicator lamp for the front wheels and the A2 indicator lamp for the rear wheels.

### B - STEERING SELECTION LEVER

- B1 - Front drive wheels (highway traffic).
- B2 - Front and rear drive wheels in opposite direction (short steering lock).
- B3 - Front and rear drive wheels in the same direction (crab steering).

### CHECKING WHEEL ALIGNMENT

#### ⚠ IMPORTANT ⚠

*Before driving on roads, it is necessary to check the alignment of the rear wheels and to drive in front wheel steering mode.*

*The alignment of the rear wheels must be regularly checked done using the green indicator lamps, while driving the lift truck.*

*In case of anomalies, consult your dealer.*

- Shift the steering selection lever B into position B2 (short steering lock).
- Turn the steering wheel and bring the rear wheels into alignment until the A2 indicator lamp comes on.
- Shift the steering selection lever B into position B1 (highway traffic).
- Turn the steering wheel and bring the front wheels into alignment until lamp A1 lights up.



## 22 - HEATER CONTROL

### A - FAN CONTROL

This 3-speed control allows the air to be ventilated through the air vents.

### B - TEMPERATURE CONTROL

Adjusts the temperature inside the cab.

- B1 - The fan pumps in the air at ambient temperature.
- B2 - The fan pumps in warm air.

The intermediate positions allow the temperature to be adjusted.

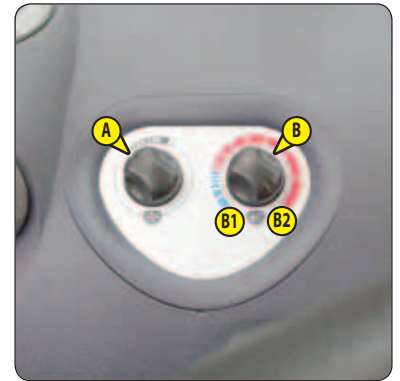

## 23 - AIR CONDITIONING CONTROLS (AIR CONDITIONING OPTION)

### ⚠ IMPORTANT ⚠

*The air conditioning only works if the lift truck has been started up. When using your air conditioning unit you must work with the cab closed.*

*In winter: So as to ensure correct operation and complete efficiency of the air conditioning unit, start up the compressor once a week, if only for a short spell, so as to lubricate the internal seals.*

*In cold weather: Warm the engine before switching on the compressor, so as to allow the coolant that has collected in a liquid state at the lowest point of the compressor circuit to turn into gas under the effect of the heat given off by the engine, as the compressor is liable to be damaged by coolant in a liquid state.*

*If your air-conditioning does not seem to be working correctly, have it examined by your dealer (see: 3 - MAINTENANCE: F - EVERY 2000 HOURS OF SERVICE).  
Never try to repair any faults yourself.*

### A - FAN CONTROL

This 3-speed control allows the air to be ventilated through the air vents.

### B - TEMPERATURE CONTROL

Adjusts the temperature inside the cab.

- B1 - The fan pumps in cold air.
- B2 - The fan pumps in warm air.

The intermediate positions allow the temperature to be adjusted.

### C - AIR CONDITIONING CONTROL

This control with a pilot light allows the air conditioning unit to be switched on.

#### HEATING MODE

- The controls must be adjusted in the following way:
  - C - Control with pilot light off.
  - B - At the required temperature.
  - A - At the desired speed: 1, 2 or 3.

#### AIR CONDITIONING MODE

- The controls must be adjusted in the following way:
  - C - Control with pilot light on.
  - B - At the required temperature.
  - A - At the desired speed: 1, 2 or 3.

#### DEMISTING MODE

- The controls must be adjusted in the following way:
  - C - Control with pilot light on.
  - B - At the required temperature.
  - A - At speed 2 or 3.
- For optimum effectiveness, close the heating ventilators.

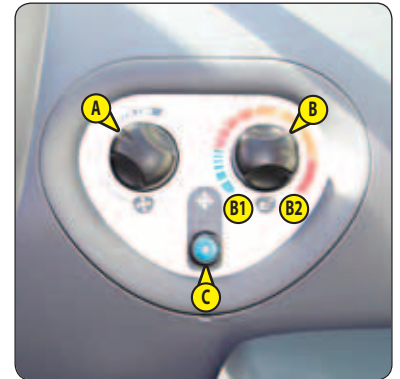

## 24 - HEATING VENTS

These swiveling heating vents, which can be shut off, allow you to direct and adjust the flow inside the cab.

## 25 - DEMIST VENTS

These vents allow the front windscreen and side windows to be demisted. For optimum efficiency, shut off the heating vents.

## **26 - LEVEL INDICATORS**

### **A - TILTING INDICATOR (OPTION)**

When the two marks are aligned, the chassis is parallel with the front axle.

### **B - SPIRIT LEVEL**

Enables the operator to check that the lift truck is in the horizontal position.



## **27 - DOOR OPEN LEVER**

## **28 - DOOR CLOSE HANDLE**

## **29 - ELECTRIC WINDOW SWITCH**

## **30 - SIDE STORAGE SPACE**

## **31 - ROOF LIGHT (CAB "COMFORT")**

### **32 - HANDLE FOR REAR WINDOW OPENING**

#### **EMERGENCY EXIT**

- Use the rear window as an emergency exit, if it is impossible to leave the cab by the door.



### **33 - HANDLE FOR REAR WINDOW CLOSING (CAB "COMFORT")**

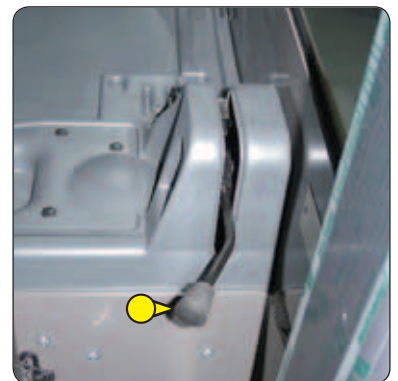

### **34 - STEERING WHEEL ADJUSTMENT LEVER (OPTION)**

This handle enables the angle and height of the steering wheel to be adjusted.

- Pull the knob backwards.
- Adjust the steering wheel to the desired position.
- Push the knob back to lock the steering wheel in position.

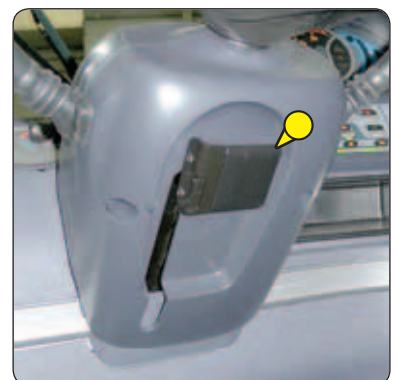

### 35 - DOCUMENT STORAGE NET (CAB "COMFORT")

Make sure that the operator's manual is in the right place, i.e. in the document holder net.

NOTE: An OPTIONAL waterproof document-holder is available.

### 36 - STORAGE COMPARTMENT

#### 37 - FRONT HEADLIGHTS

- A - Front left indicator light.
- B - Left front dipped beam headlight.
- C - Left front main beam.
- D - Left front sidelight.
- E - Right front indicator light.
- F - Right front dipped beam headlight.
- G - Right front main beam headlight.
- H - Right front sidelight.



#### 38 - REAR LIGHTS

- A - Rear left indicator light.
- B - Left rear stoplight.
- C - Left rear headlight.
- D - Rear fog light.
- E - Rear reversing light.
- F - Rear right headlight.
- G - Right rear brake light.
- H - Right rear indicator light.

**⚠ IMPORTANT ⚠**

*When driving on the road, turn back the rear lights using the bolts 1.*

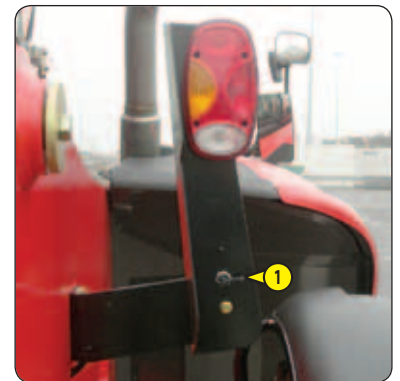
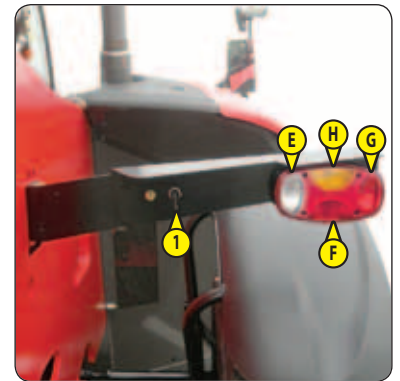
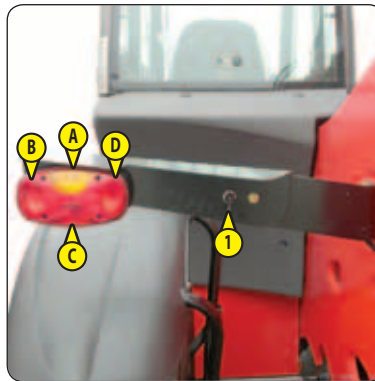

#### 39 - ROTATING BEACON LIGHT

The magnetic rotating beacon light must be clearly visible on the roof of the cab and plugged-in to socket 1.





#### 40 - INSIDE REAR-VIEW MIRROR (OPTION)

---



#### 41 - BOOM SAFETY WEDGE

---

**⚠ IMPORTANT ⚠**

*Only use the wedge supplied with the lift truck.*

The lift truck is equipped with a boom safety wedge that must be installed on the rod of the lifting cylinder when working beneath the boom (See: 1 - OPERATING AND SAFETY INSTRUCTIONS).



## TOWING PIN AND HOOK

### ⚠ IMPORTANT ⚠

*Do not tow a trailer or attachment which is not in perfect working order.*

*Using a trailer in poor condition may affect the lift truck's steering and braking, and hence safety.*

*If a third party helps in coupling or uncoupling the trailer, this person must be permanently visible to the driver and wait until the lift truck has stopped, the handbrake is on and the I.C. engine is switched off before performing the operation.*

Located at the rear of the lift truck, this device is used to attach a trailer. Its capacity is limited for each lift truck by the authorized gross vehicle weight, tractive effort and maximum vertical force on the coupling point. This information is given on the manufacturer's plate fixed to each lift truck (see: 2 - DESCRIPTION: IDENTIFICATION OF THE LIFT TRUCK).

- To use a trailer, see current regulations in your country (maximum running speed, braking, maximum weight of trailer, etc.).
- Verify the trailer's condition before using it (tyre condition and pressures, electrical connection, hydraulic hose, brake system...).

### 1 - TOWING PIN

#### ⚠ IMPORTANT ⚠

*Be careful not to get your fingers caught or crushed during this operation.*

*Do not forget to put pin back in place.*

*When uncoupling, make sure that the trailer is supported independently.*

#### COUPLING AND UNCOUPLING THE TRAILER

- To couple the trailer, position the lift truck as close as possible to the trailer ring.
- Switch off the I.C. engine.
- Remove the pin 1, lift the trailer pin 2 and place or remove the trailer ring.

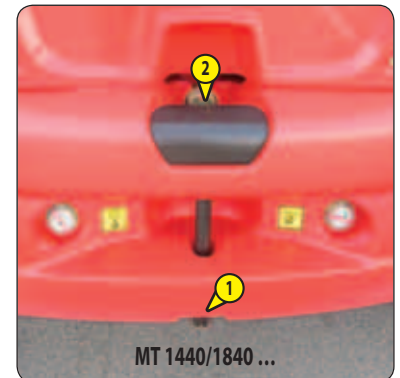
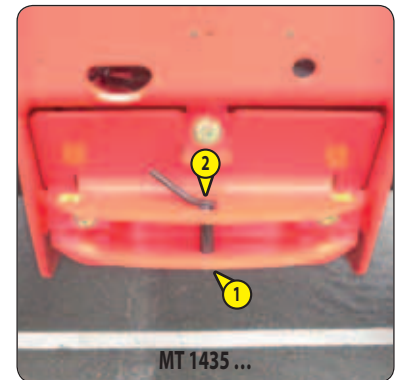

### 2 - ADJUSTABLE PROJECTING HOOK (OPTION)

MT 1440/1840 ...

#### ⚠ IMPORTANT ⚠

*Be careful not to get your fingers caught or crushed during this operation.*

*Do not forget to put pin back in place.*

*When uncoupling, make sure that the trailer is supported independently.*

#### COUPLING AND UNCOUPLING THE TRAILER

- To couple the trailer, position the lift truck as close as possible to the trailer ring.
- Switch off the I.C. engine.
- Set the coupling fitting 1 according to the height of the trailer ring.
- Remove pin 2, lift the trailer pin 3 and place or remove the trailer ring.

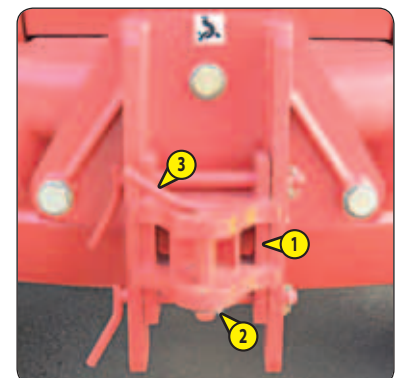

### 3 - REAR ELECTRIC SOCKET (OPTION)

- Connect the male plug to the female socket 1 on the lift truck and make sure the lights of the trailer or the light bar are working properly.

- A - Left rear indicator.
- B - OPTION Rear fog lights.
- C - Earth.
- D - Right rear indicator.
- E - Right tail light.
- F - Rear stoplight.
- G - Left rear light + number plate.

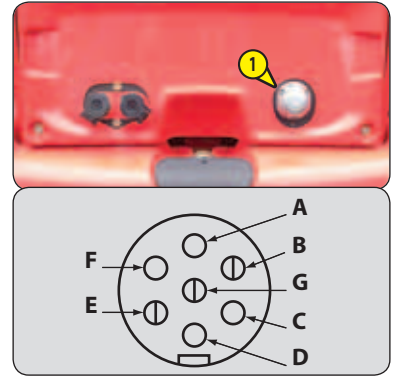

## DESCRIPTION AND USE OF THE OPTIONS

- 1 - LICENSE PLATE LIGHT
- 2 - MODCLE ANTI-START SYSTEM
- 3 - BOOM ELECTRICAL PREDISPOSITION
- 4 - QUICK-RELEASE COUPLER ON ATTACHMENT CIRCUIT
- 5 - ANGULAR SECTOR ON BOOM
- 6 - EXTERIOR DRAIN-BACK
- 7 - ATTACHMENT HYDRAULIC LOCKING
- 8 - BOOM HEAD ELECTROVALVE
- 9 - BOOM HEAD ELECTROVALVE + HYDRAULIC ATTACHMENT LOCKING
- 10 - SINGLE SIDE-SHIFT CARRIAGE (TSDL)
- 11 - DUAL EFFECT REAR HYDRAULIC CONTROL PREDISPOSITION
- 12 - LIFTING RING ON SINGLE CARRIAGE

### 1 - LICENSE PLATE LIGHT



### 2 - MODCLE ANTI-START SYSTEM

#### OPERATION

- Switch on lift truck ignition, red LED 1 will flash.
- Apply key 2 to its base 3, and withdraw the moment the system emits a continuous beep, and LED 1 turns green.
- Start the lift truck within the next 20 seconds; otherwise the anti-theft system will be reactivated and red LED 1 will flash.

NOTE: You can restart the lift truck within 20 seconds of stopping it: after this time, the anti-start system reacts and LED C flashes red.

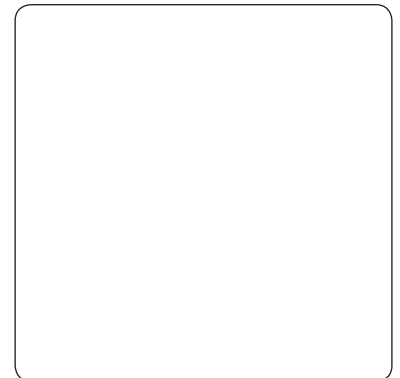

### 3 - BOOM ELECTRICAL PREDISPOSITION

MT 1435/1440 ...

Enables an electrical function to be used at the head of the boom.

#### OPERATION

- Set switch 1 to position A to enable the predisposition. The indicator lamp comes on to show that it is enabled.

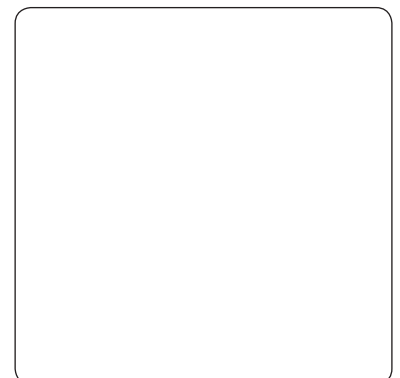

#### **4 - QUICK-RELEASE COUPLER ON ATTACHMENT CIRCUIT**

---



#### **5 - ANGULAR SECTOR ON BOOM**

---

The angular sector displays the boom angle, and thus improves the reading of the load charts.



#### **6 - EXTERIOR DRAIN-BACK**

---

Allows the connection of an attachment for which drain-back is required.

- A - Fixed position, drain-back not connected.
- B - Movable position, drain-back connected.

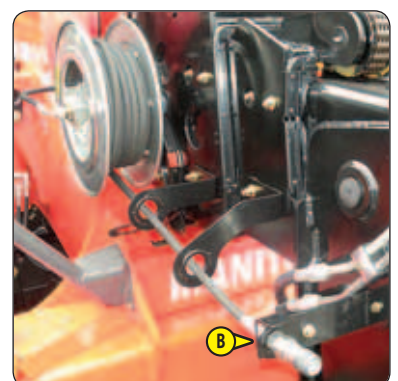
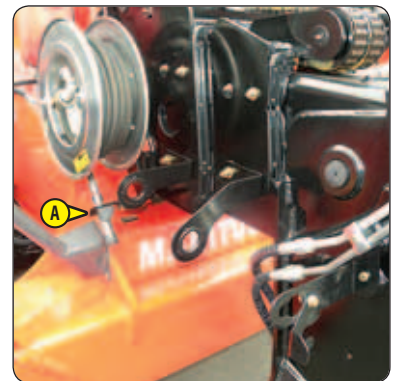

## 7 - ATTACHMENT HYDRAULIC LOCKING

Enables the attachment to be locked onto the carriage and a hydraulic attachment to be used by the same hydraulic circuit.

### ⚠ IMPORTANT ⚠

*Once the attachment is locked, return valve 1 to position A to prevent accidental release of the attachment.*

#### ATTACHMENT LINE CONTROL

- Set valve 1 to position A.
- Push switch 2 forward or backward.

#### ATTACHMENT LOCKING CONTROL

- Set valve 1 to position B.
- Push switch 2 forward to lock the attachment and backward to release it.

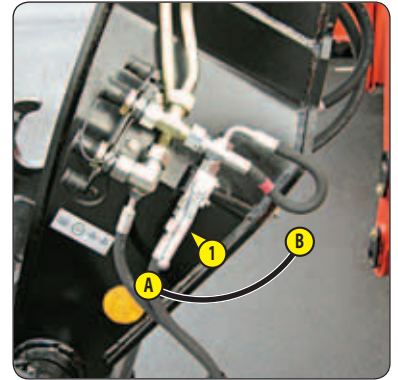

## 8 - BOOM HEAD ELECTROVALVE

Enables use of two hydraulic functions on the attachment circuit.

#### ATTACHMENT LINE L1 CONTROL

- Push switch 1 forward or backward.

#### ATTACHMENT LINE L2 CONTROL

- Hold down button 2 and operate button 1 forwards or backwards.

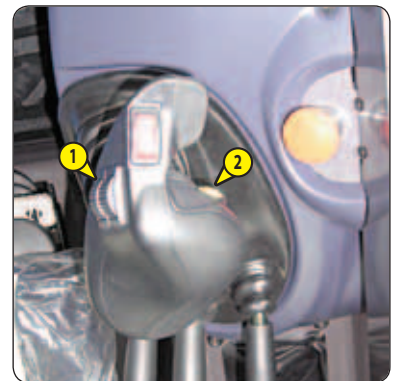
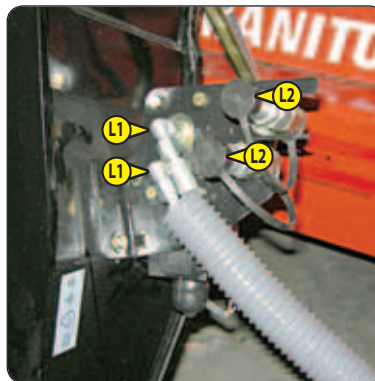

## 9 - BOOM HEAD ELECTROVALVE + HYDRAULIC ATTACHMENT LOCKING

The addition of these two options on the attachment line allows two hydraulic functions to be used and locks the attachment onto the carriage.

### ⚠ IMPORTANT ⚠

*Once the attachment is locked, return valve 1 to position A to prevent accidental release of the attachment.*

#### ATTACHMENT LINE L1 CONTROL

- Set valve 1 to position A.
- Push switch 2 forward or backward.

#### ATTACHMENT LINE L2 CONTROL

- Set valve 1 to position A.
- Hold down button 3 and operate button 2 forwards or backwards.

#### ATTACHMENT LOCKING CONTROL

- Set valve 1 to position B.
- Hold down button 3 and push button 2 forward to lock the attachment and backward to release it.

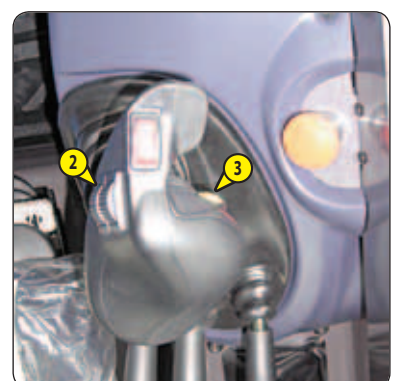
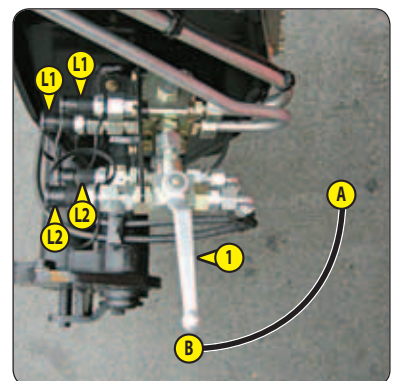

## 10 - SINGLE SIDE-SHIFT CARRIAGE (TSDL)

### **⚠ IMPORTANT ⚠**

The single side-shift carriage (TSDL) is only compatible with the following attachments:

- floating fork carriage (TFF)
- tilting fork carriage (PFB)
- loading bucket (CBR)
- concrete bucket (BB, BBG)
- chute bucket (GL)
- crane boom and crane boom with winch (P, PT, PO, PC)
- winch (H)
- fixed platform, swivelling platform, roofer's platform.

The use of any other attachment on the TSDL is forbidden.

If it is being used with a loading bucket (CBR), the single side-shift carriage **MUST** be centred and no side-shift operations performed.

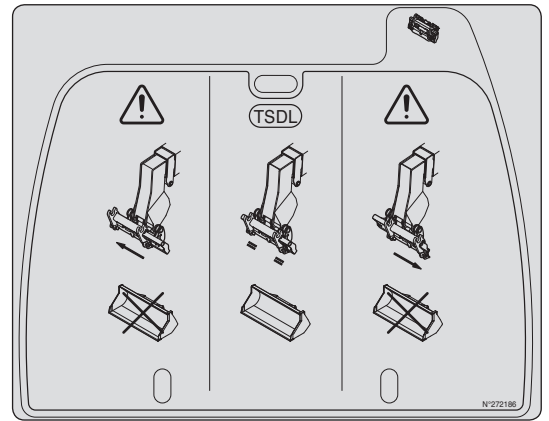

### WITH BOOM HEAD COUPLER

#### ATTACHMENT LINE CONTROL

- Set valve 1 to position A.
- Push switch 2 forward or backward.

#### TSDL CONTROL

- Set valve 1 to position B.
- Push button 2 forward to move sideways to the right, and backward to move sideways to the left.

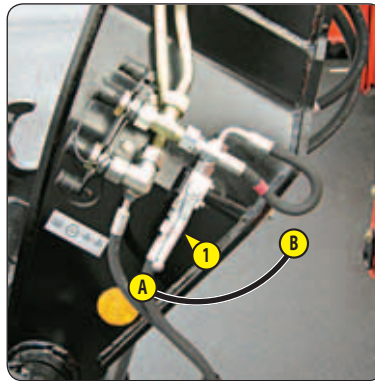

### WITH BOOM HEAD ELECTROVALVE

#### TSDL LINE L1 CONTROL

- Push button 2 forward to move sideways to the right, and backward to move sideways to the left.

#### ATTACHMENT LINE L2 CONTROL

- Hold down button 3 and operate button 2 forwards or backwards.

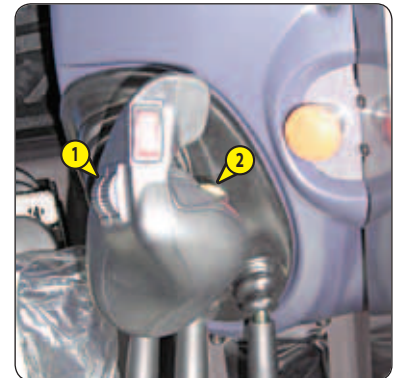
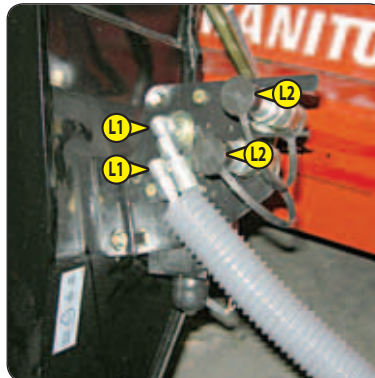

### WITH BOOM HEAD ELECTROVALVE + PREARRANGED HYDRAULIC ATTACHMENT LOCKING

### **⚠ IMPORTANT ⚠**

Once the attachment is locked, return valve 1 to position A to prevent accidental release of the attachment.

#### TSDL LINE L1 CONTROL

- Push button 2 forward to move sideways to the right, and backward to move sideways to the left.

#### ATTACHMENT LINE L2 CONTROL

- Set valve 1 to position A.
- Hold down button 3 and operate button 2 forwards or backwards.

#### ATTACHMENT LOCKING CONTROL

- Set valve 1 to position B.
- Hold down button 3 and push button 2 forward to lock the attachment and backward to release it.

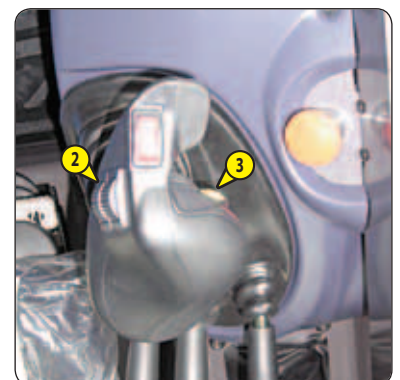
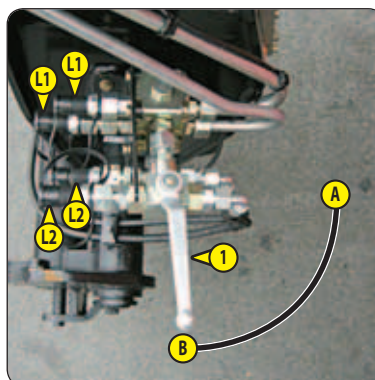

## 11 - DUAL EFFECT REAR HYDRAULIC CONTROL PREDISPOSITION

Enables the use of a hydraulic attachment at the rear of the lift truck (e.g. a trailer with hydraulic tipping).

- Press down on switch 1 (indicator lamp lit) to power the hydraulic control at the rear of the lift truck.
- Push switch 2 forward or backward.

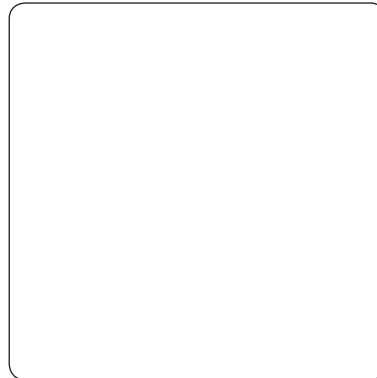

## 12 - LIFTING RING ON SINGLE CARRIAGE

### CONDITIONS OF USE



*Follow the instructions given in your lift truck's instruction manual (see: 1 - OPERATING AND SAFETY INSTRUCTIONS ON HANDLING LOADS), in addition to those given below.*

- The lifting ring must be used WITHOUT FORKS AND ATTACHMENTS, but the angle of inclination of the carriage must be same as when the forks are used in the horizontal position.
- Check the maximum authorized angle, which is 45°, on the screen.
- Do not change the angle of the carriage while using the lifting ring.
- The lifting hook, the chains and slings shall have a minimum capacity of 3000 kg with a factor of safety against breakage of 4.

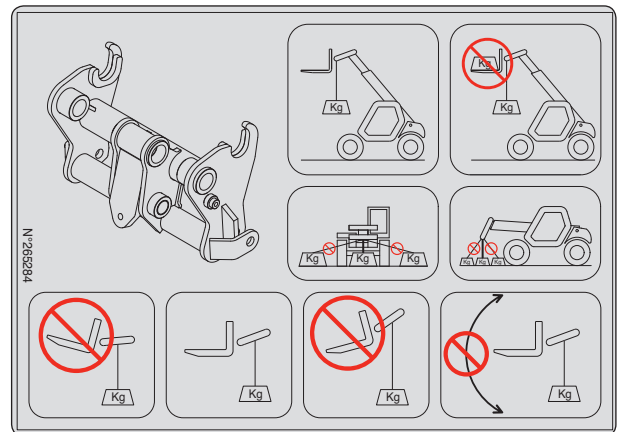

### LOAD CHARTS AND FUNCTION SHEETS



*The load charts are given for use without forks and without attachments.*

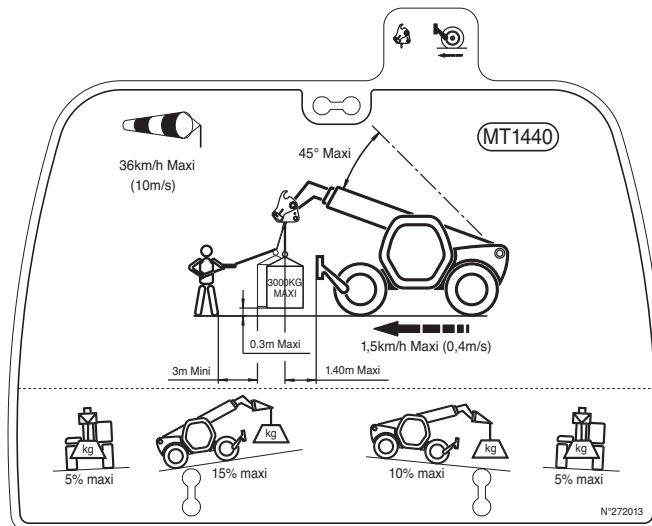



# ***3 - MAINTENANCE***



# TABLE OF CONTENTS

## 3 - MAINTENANCE

<i>ORIGINAL MANITOU SPARE PARTS AND EQUIPMENT</i>	<b>4</b>
<i>FILTERS CARTRIDGES AND BELTS</i>	<b>5</b>
<i>LUBRICANTS AND FUEL</i>	<b>6</b>
<i>SERVICING SCHEDULE</i>	<b>8</b>
<i>A - DAILY OR EVERY 10 HOURS OF SERVICE</i>	<b>10</b>
<i>B - EVERY 50 HOURS OF SERVICE</i>	<b>14</b>
<i>C - EVERY 250 HOURS OF SERVICE</i>	<b>20</b>
<i>D - EVERY 500 HOURS OF SERVICE OR EVERY YEAR</i>	<b>22</b>
<i>E - EVERY 1000 HOURS OF SERVICE OR TWO YEARS</i>	<b>26</b>
<i>F - EVERY 2000 HOURS OF SERVICE OR EVERY TWO YEARS</i>	<b>32</b>
<i>G - OCCASIONAL MAINTENANCE</i>	<b>36</b>

## ORIGINAL MANITOU SPARE PARTS AND EQUIPMENT

OUR LIFT TRUCKS MUST BE SERVICED USING ORIGINAL MANITOU PARTS.

### **BY ALLOWING THE USE OF NON ORIGINAL MANITOU PARTS, YOU RISK:**

---

- Legally -to be held responsible in the event of an accident.
- Technically - to cause operating malfunctions or shorten the life of the lift truck.

**⚠ IMPORTANT ⚠**

**THE USE OF COUNTERFEIT PARTS OR COMPONENTS NOT APPROVED BY THE MANUFACTURER,  
WILL CAUSE YOU TO LOSE THE BENEFIT OF THE CONTRACTUAL GUARANTEE.**

### **BY USING ORIGINAL MANITOU PARTS FOR MAINTENANCE OPERATIONS, YOU BENEFIT FROM OUR KNOW-HOW**

---

Through its network, MANITOU provides the user with,

- Know-how and competence.
- The guarantee of high-quality work.
- Original replacement parts.
- Help with preventive maintenance.
- Efficient help with diagnosis.
- Improvements due to experience feedback.
- Operator training.
- Only the MANITOU network has detailed knowledge of the design of the lift truck and therefore the best technical ability to provide maintenance.

**⚠ IMPORTANT ⚠**

**ORIGINAL REPLACEMENT PARTS ARE DISTRIBUTED EXCLUSIVELY BY MANITOU AND ITS DEALER NETWORK.**

*The dealer network list is available on the MANITOU web site [www.manitou.com](http://www.manitou.com)*

## FILTERS CARTRIDGES AND BELTS

### ENGINE

ENGINE OIL FILTER  
Part number: 799966  
Change: 500 H

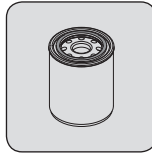

FUEL TANK BREATHER  
Part number: 266219  
Change: 1000 H

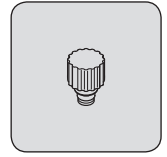

DRY AIR FILTER CARTRIDGE  
Part number: 797903  
Change: 1000 H

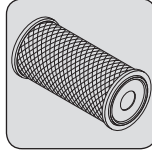

ALTERNATOR BELT  
Part number: 941243  
Change: 1000 H

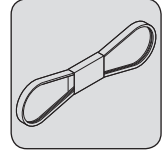

SAFETY DRY AIR FILTER CARTRIDGE  
Part number: 797904  
Change: 2000 H

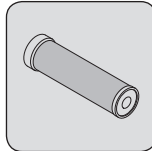

COMPRESSOR BELT  
(AIR CONDITIONING OPTION)  
Part number: 216125

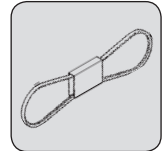

FUEL PRE-FILTER  
Part number: 799968  
Change: 1000 H

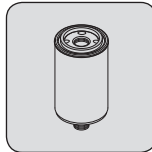

FUEL FILTER  
Part number: 799967  
Change: 1000 H

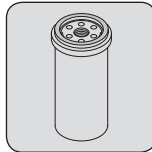

### TRANSMISSION

GEAR BOX OIL FILTER  
Part number: 745878  
Change: 1000 H

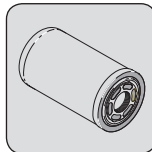

### HYDRAULIC SYSTEM

HYDRAULIC RETURN OIL FILTER CARTRIDGE  
Part number: 311821  
Change: 500 H

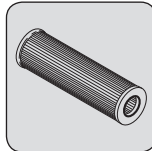

SUCTION STRAINER FOR HYDRAULIC OIL TANK  
Part number: 52522593  
Clean: 2000 H

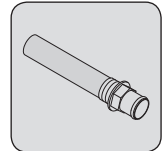

BREATHER FOR THE HYDRAULIC OIL TANK  
Part number: 261487  
Change: 2000 H

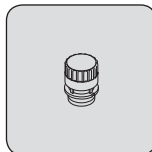

BRAKE ACCUMULATOR UNIT FILTER  
Part number: 746308  
Change: 2000 H

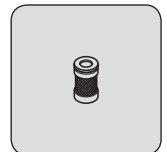

### CAB

EXTERIOR CAB VENTILATION FILTER  
Part number: 261971  
Clean: 50 H  
Change: 250 H

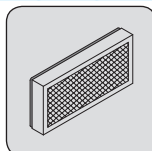

INTERIOR CAB VENTILATION FILTER  
Part number: 958671  
Clean: 50 H  
Change: 250 H



# LUBRICANTS AND FUEL

## ⚠ IMPORTANT ⚠

USE THE RECOMMENDED LUBRICANTS AND FUEL:

- For topping up, oils may not be miscible.
- For oil changes, MANITOU oils are perfectly appropriate.

### DIAGNOSTIC ANALYSIS OF OILS

If a service or maintenance contract has been organized with the dealer, a diagnostic analysis of engine, transmission and axle oils may be requested depending on the rate of use.

### (\*) REQUIRED FUEL SPECIFICATION

Use a high-quality fuel to obtain optimal performance of the engine.

- EN590 diesel fuel (sulfur content < 10 ppm)
- ASTM D975 diesel fuel (sulfur content < 15 ppm)

### RECOMMENDATION

I.C. ENGINE		RECOMMENDATION										
PARTS TO BE LUBRICATED	CAPACITY	-40°C	-30	-20	-10	0	+10	+20	+30	+40	+50°C	
I.C. ENGINE	9 Liters	0W20										
		0W30										
		0W40										
		5W30										
		5W40										
		10W30										
		MANITOU EVOLGY OIL 10W40 API CJ4										
15W40												
COOLING CIRCUIT	17 Liters	COOLING LIQUID -35°C										
FUEL TANK	140 Liters	GMR HP DIESEL *										

TRANSMISSION		RECOMMENDATION										
PARTS TO BE LUBRICATED	CAPACITY	-40°C	-30	-20	-10	0	+10	+20	+30	+40	+50°C	
GEAR BOX	21,1 Liters	MANITOU AUTOMATIC TRANSMISSION OIL DX IIIG										

BOOM		RECOMMENDATION										
PARTS TO BE LUBRICATED	CAPACITY	-40°C	-30	-20	-10	0	+10	+20	+30	+40	+50°C	
BOOM PADS		MANITOU BLACK MULTI-USE LUBRICANT										
GREASING THE BOOM		MANITOU BLUE MULTI-USE LUBRICANT										
BOOM CHAINS MT 1840 ...		MANITOU SPECIAL CHAINS LUBRICANT										

HYDRAULIC		RECOMMENDATION										
PARTS TO BE LUBRICATED	CAPACITY	-40°C	-30	-20	-10	0	+10	+20	+30	+40	+50°C	
HYDRAULIC OIL TANK	115 Liters	ISO VG 100										
		ISO VG 68										
		MANITOU ISO VG 46 HYDRAULIC OIL										
		ISO VG 37										
		ISO VG 32										

BRAKE		RECOMMENDATION										
PARTS TO BE LUBRICATED	CAPACITY	-40°C	-30	-20	-10	0	+10	+20	+30	+40	+50°C	
BRAKING CIRCUIT	1 Liter	MANITOU MINERAL BRAKE FLUID										

<b>CAB</b>		
PARTS TO BE LUBRICATED	CAPACITY	RECOMMENDATION
WINDSCREEN WASHER TANK	8 Liters	WINDSCREEN WASHER LIQUID

<b>FRONT AXLE</b>		
PARTS TO BE LUBRICATED	CAPACITY	RECOMMENDATION
FRONT AXLE DIFFERENTIAL	7,2 Liters	SPECIAL MANITOU OIL FOR IMMersed BRAKES
		-40°C -30 -20 -10 0 +10 +20 +30 +40 +50°C
FRONT WHEEL REDUCERS	2 x 0,75 Liter	MANITOU SAE80W90 MECHANICAL TRANSMISSION OIL
		-40°C -30 -20 -10 0 +10 +20 +30 +40 +50°C
FRONT WHEEL REDUCTION GEAR PIVOTS FRONT AXLE OSCILLATION (OPTION)		MANITOU BLUE MULTI-USE LUBRICANT

<b>REAR AXLE</b>		
PARTS TO BE LUBRICATED	CAPACITY	RECOMMENDATION
REAR AXLE DIFFERENTIAL	7,2 Liters	SPECIAL MANITOU OIL FOR IMMersed BRAKES
		-40°C -30 -20 -10 0 +10 +20 +30 +40 +50°C
REAR WHEEL REDUCER	2 x 0,75 Liter	MANITOU SAE80W90 MECHANICAL TRANSMISSION OIL
		-40°C -30 -20 -10 0 +10 +20 +30 +40 +50°C
REAR WHEEL REDUCTION GEAR PIVOTS REAR AXLE OSCILLATION		MANITOU BLUE MULTI-USE LUBRICANT

<b>CHASSIS</b>		
PARTS TO BE LUBRICATED		RECOMMENDATION
		-40°C -30 -20 -10 0 +10 +20 +30 +40 +50°C
LEVELING CORRECTOR (OPTION) STABILISERS		MANITOU BLUE MULTI-USE LUBRICANT

<b>ATTACHMENT</b>		
PARTS TO BE LUBRICATED		RECOMMENDATION
		-40°C -30 -20 -10 0 +10 +20 +30 +40 +50°C
SINGLE SIDE-SHIFT CARRIAGE (TSDL) (OPTION)		MANITOU BLUE MULTI-USE LUBRICANT

## PACKAGING

<b>OIL</b>						
PRODUCT	PACKAGING / REFERENCE					
	1 LITER	2 LITERS	5 LITERS	20 LITERS	55 LITERS	209 LITERS
- MANITOU EVOLOGY OIL 10W40 API CJ4			895837	895838	895839	895840
- MANITOU OIL AUTOMATIC TRANSMISSION DX IIIG	958186		947972	947973	947974	947975
- MANITOU ISO VG 46 HYDRAULIC OIL			545500	582297	546108	546109
- MANITOU MINERAL BRAKE FLUID	490408					4500078
- SPECIAL MANITOU OIL FOR IMMersed BRAKES			545976	582391		894257
- MANITOU SAE80W90 MECHANICAL TRANSMISSION OIL		499237	720184	546330	546221	546220

<b>LUBRICANT</b>						
PRODUCT	PACKAGING / REFERENCE					
	400 ML	400 GR	1 KG	5 KG	20 KG	50 KG
- MANITOU BLACK MULTI-USE LUBRICANT		947766	161590			499235
- MANITOU BLUE MULTI-USE LUBRICANT		161589	720683	554974	499233	489670
- MANITOU SPECIAL CHAINS LUBRICANT	554271					

<b>LIQUID</b>						
PRODUCT	PACKAGING / REFERENCE					
	1 LITER	2 LITERS	5 LITERS	20 LITERS	55 LITERS	210 LITERS
- COOLING LIQUID -35°C			894967	894968		894969
- WINDSCREEN WASHER LIQUID	490402		486424			

# SERVICING SCHEDULE

## ⚠ IMPORTANT ⚠

(1): MANDATORY 500 HOUR OR 6 MONTH SERVICE. This service must be carried out after approximately the first 500 hours of operation or within the 6 months following the start-up of the machine (whichever occurs first).

(2): Every 10 hours during the first 50 hours then a final time at 250 hours.

(3): Contact your dealer.

A = ADJUST, C = CHECK, G = GREASE, N = CLEAN, P = BLEED, R = REPLACE, V = DRAIN	PAGE	(1)	DAILY OR EVERY 10 HOURS OF SERVICE	EVERY 50 HOURS OF SERVICE	EVERY 250 HOURS OF SERVICE	EVERY 500 HOURS OF SERVICE OR EVERY YEAR	EVERY 1000 HOURS OF SERVICE OR EVERY TWO YEARS	EVERY 2000 HOURS OF SERVICE OR EVERY TWO YEARS	EVERY 4000 HOURS OF SERVICE	OCCASIONAL
<b>ENGINE</b>										
- Engine oil level	3-10		C							
- Cooling liquid level	3-10		C							
- Fuel level	3-10		C							
- Fuel pre-filter	3-10		C							
- Dry air filter cartridge	3-14/26	R		C/N			R			
- Radiator core	3-14	N		N						
- Engine oil	3-22	V				V				
- Engine oil filter	3-22	R				R				
- Alternator/fan/crankshaft belt tension	3-23	C/A				C/A				
- Compressor belt tension (Air-conditioning OPTION)	3-23	C/A				C/A				
- Fuel pre-filter	3-26	R					R			
- Fuel filter	3-27	R					R			
- Fuel tank	3-27						N			
- Fuel tank breather	3-27						R			
- Alternator/fan/crankshaft belt	3-28						R			
- Engine silent blocks							C (3)			
- Engine speeds							C (3)			
- Valve clearances		C					C (3)			
- Cooling liquid	3-32							V		
- Safety dry air filter cartridge	3-32							R		
- Radiator								C (3)		
- Water pump and the thermostat								C (3)		
- Alternator and the starter motor								C (3)		
- Turbo compressor								C (3)		
<b>TRANSMISSION</b>										
- Gear box oil level	3-14			C						
- Gear box oil	3-28	V					V			
- Gear box oil filter	3-28	R					R			
- Silent blocks in the gear box							C (3)			
- Gear box controls							C (3)			
- Transmission pressure								C (3)		
- Wear of the brake pads and the brake disk									C (3)	
<b>TYRES</b>										
- Tyre pressures	3-15	C		C						
- Wheel nut tightening	3-15	C		C						
- Wheel nut tightening torques	3-32	C						C		
- Wheel	3-36									R
<b>BOOM</b>										
- Boom pads	3-11		N/G (2)							
- Boom	3-16	G		G						
- Outer boom chains MT 1840 ...	3-20	N/G/C			N/G/C					
- Outer boom chain wear MT 1840 ...	3-29						C			
- Boom pad wear							C (3)			
- Condition of boom assembly		C						C (3)		
- Bearings and articulation rings								C (3)		
- Inner boom chain wear MT 1840 ...									C (3)	
<b>HYDRAULIC SYSTEM</b>										
- Hydraulic oil level	3-18	C		C						
- Hydraulic return oil filter cartridge	3-24	R				R				
- Hydraulic oil	3-24/33					C		V		
- Breather for the hydraulic oil tank	3-33							R		
- Suction strainer for hydraulic oil tank	3-33							N		
- Brake accumulator unit filter	3-33							R		
- Hydraulic pump tubular filter								N (3)		
- Condition of hoses and flexible pipes								C (3)		
- Condition of cylinders (leakage, rods)								C (3)		



A = ADJUST, C = CHECK, G = GREASE, N = CLEAN, P = BLEED, R = REPLACE, V = DRAIN	PAGE	(1)	DAILY OR EVERY 10 HOURS OF SERVICE	EVERY 50 HOURS OF SERVICE	EVERY 250 HOURS OF SERVICE	EVERY 500 HOURS OF SERVICE OR EVERY YEAR	EVERY 1000 HOURS OF SERVICE OR EVERY TWO YEARS	EVERY 2000 HOURS OF SERVICE OR EVERY TWO YEARS	EVERY 4000 HOURS OF SERVICE	OCCASIONAL
- Hydraulic circuit pressures								C (3)		
<b>BRAKE</b>										
- Brake oil level	3-18	C		C						
- Brake oil							V (3)			
- Brake system							P (3)			
- Brake system pressure							C (3)			
- Brake							A (3)			
<b>STEERING</b>										
- Steering								C (3)		
- Steering swivel joints									C (3)	
<b>CAB</b>										
- Windscreen washer liquid level	3-18	C		C						
- Cab ventilation filters	3-19/20	R		N	R					
- Condenser core (Air-conditioning OPTION)	3-19	C/N		C/N						
- Seat belt	3-30						C			
- Condition of the rear view mirrors							C (3)			
- Structure							C (3)			
- Air conditioning (OPTION)	3-34							N/C		
<b>ELECTRICITY</b>										
- Longitudinal stability limiter and warning device	3-12/37	C	C							XXX
- Condition of wiring harness and cables							C (3)			
- Lights and signals							C (3)			
- Warning indicators							C (3)			
- Front headlights	3-38									A
- Battery failure	3-38									R
<b>FRONT AXLE</b>										
- Front wheel reducing gear pivots	3-16	G		G					G/C (3)	
- Front axle oscillation (OPTION)	3-16	G		G				G/C (3)		
- Front axle differential oil level	3-21				C					
- Front wheel reduction gear oil level	3-21				C					
- Front axle differential oil	3-25	V				V				
- Front wheel reduction gear oil	3-30	V					V			
- Wear of front axle brake discs									C (3)	
- Front wheel reduction gear universal joint									C (3)	
- Front wheel reduction gear clearance									C (3)	
<b>REAR AXLE</b>										
- Rear wheel reducing gear pivots	3-16	G		G					G/C (3)	
- Rear axle oscillation	3-16	G		G				G/C (3)		
- Rear axle differential oil level	3-21				C					
- Rear wheel reduction gear oil level	3-21				C					
- Rear axle differential oil	3-25	V				V				
- Rear wheel reduction gear oil	3-30	V					V			
- Wearing of rear axle brake discs									C (3)	
- Rear wheel reduction gear universal joint									C (3)	
- Rear wheel reduction gear clearance									C (3)	
<b>FRAME</b>										
- Levelling corrector (OPTION)	3-16	G		G						
- Stabilisers	3-16	G		G						
- Structure							C (3)			
- Bearings and articulation rings								C (3)		
<b>ATTACHMENTS</b>										
- Single side-shift carriage (TSDL) (OPTION)	3-16	G		G						
- Fork wear		C				C (3)				
- Attachment carriage							C (3)			
- Condition of attachments							C (3)			
<b>LIFT TRUCK</b>										
- Towing the lift truck	3-39									XXX
- Sling the lift truck	3-39									XXX
- Transport the lift truck on a platform	3-40									XXX

## A - DAILY OR EVERY 10 HOURS OF SERVICE

### A1 - ENGINE OIL LEVEL

CHECK

Place the lift truck on level ground with the engine stopped, and let the oil settle in the sump.

- Open the engine bonnet.
- Pull out dipstick 1.
- Clean the dipstick and check the correct level between the two notches.
- If necessary, add oil (see: 3 - MAINTENANCE: LUBRICANTS AND FUEL) through the filler port 2.
- Visually check that there is no leakage or seepage of oil in the engine.

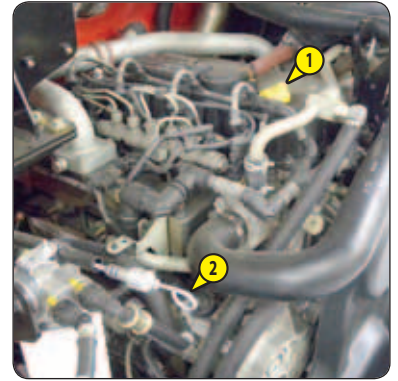

### A2 - COOLING LIQUID LEVEL

CHECK

Place the lift truck on level ground with the engine stopped, and allow the engine to cool.

**⚠ IMPORTANT ⚠**

*To avoid any risk of spraying or burning, wait until the engine has cooled down before removing the cooling circuit filler plug.*

*If the cooling liquid is very hot, add only hot cooling liquid (80°C).*

*In an emergency, you can use water as a coolant, then change the coolant as soon as possible (see: 3 - MAINTENANCE: F1 - COOLANT).*

- Open the engine bonnet.
- The liquid must be at the MAXIMUM level on the expansion tank 1.
- If necessary, add coolant (see: 3 - MAINTENANCE: LUBRICANTS AND FUEL) through the filler port 2.
- Visually check that there is no leakage in the radiator and pipes.



### A3 - FUEL LEVEL

CHECK

As far as possible, keep the fuel tank well filled in order to minimize condensation due to the atmospheric conditions.

**⚠ IMPORTANT ⚠**

*Never smoke or approach with a flame during filling operations or when the tank is open.*

*Never refill while the engine is running.*

- Check the fuel gage on the instrument panel.
- If necessary, add diesel (see: 3 - MAINTENANCE: LUBRICANTS AND FUEL).
- Open the access panel for hydraulic oil filling.
- Remove the cap 1 using the ignition key.
- Fill the fuel tank with clean diesel filtered through the filler port 2.
- Refit the cap.
- Visually check that there is no leakage in the tank and pipes.

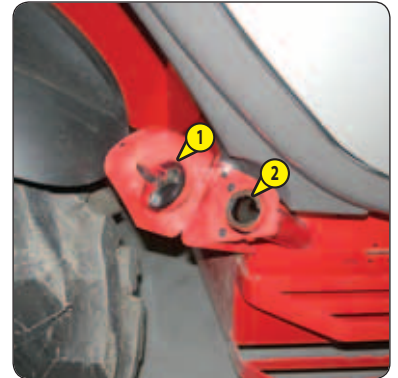

### A4 - FUEL PRE-FILTER

CHECK

**⚠ IMPORTANT ⚠**

*Carefully clean the outside of the pre-filter and its holder, to prevent dust from getting into the system.*

- Open the engine bonnet.
- Disconnect electrical wiring harness 1 from the fuel pre-filter.
- Place a receptacle under the drain plug 2 and unscrew by two to three turns.
- Allow the diesel fuel to flow out until it is free from impurities and water.
- Re-tighten drain plug 2 and reconnect the wiring harness 1.

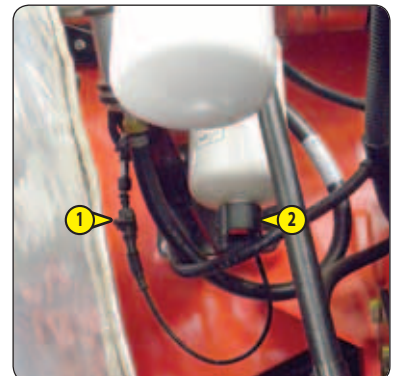

## A5 – BOOM PADS

### CLEAN - GREASE

To be carried out every 10 hours during the first 50 hours service, then once at 250 hours.

#### **⚠ IMPORTANT ⚠**

*If the lift truck is used in an abrasive environment (dust, sand, coal) Use lubricating varnish (MANITOU part no.: 483536). Please consult your dealer. Fully extend the boom.*

- Apply the grease with a brush (see: 3 - MAINTENANCE: LUBRICANTS AND FUEL) to the 4 sides of the telescope(s).
- Telescope the boom several times in order to spread the coat of grease evenly.
- Remove the surplus of grease.















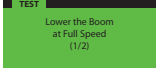

**⚠ IMPORTANT ⚠**

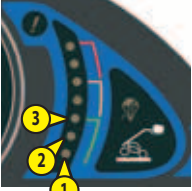
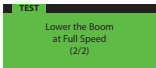
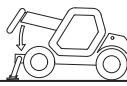

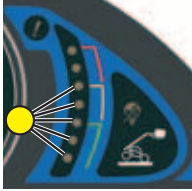
*If there is any doubt during the test procedure, exit by briefly pressing the cancel button.*

- These tests are essential for checking the correct operation and adjustment of the different components of the device.
- Place the lift truck on flat, level ground with the wheels straight.

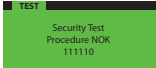
- Hold down the test button .

<p><b>STEP 1</b> ↓</p>	 <ul style="list-style-type: none"> <li>- First green LED flashing.</li> <li>- Test button lit.</li> <li>- Screen display. </li> <li>- An audible beep.</li> </ul>	 <p>→</p> <ul style="list-style-type: none"> <li>- Place the forklift truck with no attachments, with the left and right-hand stabilisers on the ground, the front wheels off the ground and the boom fully retracted and raised.</li> </ul>	<p>→ <b>Briefly press the button</b>  →</p> <ul style="list-style-type: none"> <li>- Go to stage 2.</li> </ul>
<p><b>STEP 2</b> ↓</p>	 <ul style="list-style-type: none"> <li>- First green LED continuously lit.</li> <li>- Second green LED flashing.</li> <li>- Test button lit.</li> <li>- Screen display. </li> </ul>	 <p>→</p> <ul style="list-style-type: none"> <li>- Lower the boom with the engine running at full speed and the hydraulic control at the maximum setting. Slowing of lowering until movement is cut off.</li> </ul>	<p>→ <b>Briefly press the button</b>  →</p> <ul style="list-style-type: none"> <li>- Go to stage 3.</li> </ul>
<p><b>STEP 3</b></p>	 <ul style="list-style-type: none"> <li>- First and second green LEDs continuously lit.</li> <li>- Third green LED flashing.</li> <li>- Test button lit.</li> <li>- Screen display. </li> </ul>	 <p>→</p> <ul style="list-style-type: none"> <li>- Continue to lower the boom with the engine running at full speed and the hydraulic control at the maximum setting. Slow lowering until the next movement cut-off.</li> </ul>	<p>→ <b>Briefly press the button</b>  →</p> <div style="text-align: right;"> <p><b>TEST OK</b></p>  </div> <ul style="list-style-type: none"> <li>- First 5 LEDs lit.</li> <li>- Screen display. </li> <li>- Press the button  to exit test mode.</li> </ul> <p style="text-align: right;"><b>TEST NOT OK</b></p> <ul style="list-style-type: none"> <li>- See stage 4.</li> </ul>
<p><b>STEP 4</b></p>	<ul style="list-style-type: none"> <li>- The fault warning light  continues flashing until the error is repaired.</li> <li>- Screen display. </li> </ul>	<p>→</p> <ul style="list-style-type: none"> <li>- The combination is the result of tests carried out in the following order (1 = test OK; 0 = fault detected):                     <ul style="list-style-type: none"> <li>• 1st number: Telescope retracted sensor fault.</li> <li>• 2nd number: Right or left stabiliser sensor fault.</li> <li>• 3rd number: Boom angle sensor fault.</li> <li>• 4th number: Strain gauge fault.</li> <li>• 5th number: Safety valve fault.</li> <li>• 6th number: Control fault.</li> </ul> </li> <li>- Consult your dealer and provide the combination.</li> <li>- Press the button  to exit test mode.</li> </ul>	



## B - EVERY 50 HOURS OF SERVICE

Carry out the operations described previously as well as the following operations.

### B1 – DRY AIR FILTER CARTRIDGE

CHECK - CLEAN

In case of use in a heavily dust laden atmosphere, there are pre-filtration cartridges (see: 3 - MAINTENANCE: FILTERS CARTRIDGES AND BELTS). Also, the checking and cleaning periodicity of the cartridge must be reduced.

#### ⚠ IMPORTANT ⚠

*If the clogging indicator light comes on, this operation must be carried out as quickly as possible (1 hour maximum). The cartridge must not be cleaned more than seven times, after which the cartridge must be changed. Never use the lift truck without an air filter or with a damaged air filter.*

*Respect the safety distance of 30 mm between the air jet and the cartridge to avoid tearing or making a hole in the cartridge. The cartridge must not be blown anywhere near the air filter box. Never clean the cartridge by tapping it against a hard surface. Your eyes must be protected during this intervention.*

*Never clean the dry air filter cartridge by washing it in liquid. Do not clean by any means the safety cartridge located inside the filter cartridge, change it for a new one if it is clogged or damaged*

- For the dismantling and reassembly of the cartridge, see: 3 - MAINTENANCE: E1 - AIR FILTER CARTRIDGE.
- Clean the filter cartridge using a compressed air jet (max. pressure 3 bar) directed from the top to the bottom and from the inside towards the outside at a minimum distance of 30 mm from the cartridge wall.
- Cleaning is completed when there is no more dust on the cartridge.
- Clean the cartridge seal surfaces with a damp, clean lint-free cloth and grease with a silicone lubricant (MANITOU part no.: 479292).
- Check visually the outer condition of the air filter and its mounts. Verify the condition of the hoses and their mounts also.

### B2 – RADIATOR CORE

CLEAN

#### ⚠ IMPORTANT ⚠

*In a polluting atmosphere, clean the radiator core every day. Do not use a water jet or high-pressure steam as this could damage the radiator fins.*

- Open the engine bonnet.
- If necessary, clean the suction grid on the engine hood.
- Using a soft cloth, clean the radiator in order to remove as much dirt as possible.
- Clean the radiator using a compressed air jet aimed from the engine towards the radiator, in the opposite direction to the cooling air flow.



### B3 – GEAR BOX OIL LEVEL

CHECK

Place the lift truck on level ground with the boom raised and the engine running.

#### ⚠ IMPORTANT ⚠

*Raise the boom and place the boom safety wedge on the rod of the lifting cylinder (see: 1 - INSTRUCTIONS AND SAFETY RECOMMENDATIONS: FORKLIFT TRUCK MAINTENANCE INSTRUCTIONS).*

- Remove dipstick 1 by unscrewing it.
- Wipe the dipstick and check the correct level against the MAX mark.
- If necessary, add oil (see: 3 - MAINTENANCE: LUBRICANTS AND FUEL) by the same hole.
- Retighten the gauge 1.
- Visually check that there is no leakage or seepage of oil in the gearbox.

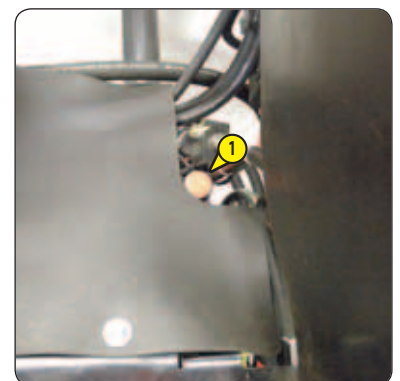

**⚠ IMPORTANT ⚠**

*Check that the air hose is correctly connected to the tyre valve before inflating and keep everyone at a distance during inflation. Adhere to the recommended tyre pressures.*

- Check the condition of the tyres, to detect cuts, blisters, wear, etc.
- Check the torque load of the wheel nuts. Non-compliance with this instruction can lead to damage and failure of the wheel bolts and distortion of the wheels.
- Check and restore tire pressures if necessary (see: 2 - DESCRIPTION: TIRES).

NOTE: There is an OPTIONAL wheel toolkit.

To be carried out weekly, if the lift truck has been operated for less than 50 hours during the week.



*In the event of prolonged use in an extremely dusty or oxidizing atmosphere, reduce this interval to every 10 hours of service or every day.*

Clean and lubricate the following points with grease (see: 3 - MAINTENANCE: LUBRICANTS AND FUEL) and remove the surplus of grease.

#### **BOOM**

- 1 - Lubricators of the boom axle (2 lubricators).
- 2 - Lubricators of the carriage axle (2 lubricators).
- 3 - Lubricator of the tilt cylinder foot axle (1 lubricator).
- 4 - Lubricator of the tilt cylinder head axle (1 lubricator).
- 5 - Lubricator of the lifting cylinder foot axle (1 lubricator).
- 6 - Lubricator of the lifting cylinder head axle (1 lubricator).
- 7 - Lubricator of the compensation cylinder foot axle (1 lubricator).
- 8 - Lubricator of the compensation cylinder head axle (1 lubricator).
- 9 - Lubricator of the chain pulley axle of telescope 2 at the boom head (1 lubricator). MT 1840 ...
- 10 - Lubricator of the chain pulley axle of telescope 1 at the boom head (1 lubricator). MT 1840 ...
- 11 - Lubricator of the chain pulley axle of telescope 1 at the boom foot (1 lubricator). MT 1840 ...
- 12 - Lubricator of the hose pulley shaft at the bottom of the boom (1 lubricator). MT 1840 ...

#### **FRONT AND REAR WHEEL REDUCTION GEAR PIVOTS**

- 13 - Lubricators of the wheel reduction gear pivot pins (8 lubricators).

#### **AXLE OSCILLATION**

- 14 - Front axle oscillation lubricators (2 lubricators) (OPTION).
- 15 - Rear axle oscillation lubricators (2 lubricators).

#### **LEVELING CORRECTOR (OPTION)**

- 16 - Lubricator of the roll corrector cylinder foot axle (1 lubricator).
- 17 - Lubricator of the roll corrector cylinder head axle (1 lubricator).

#### **STABILISERS**

- 18 - Lubricators of the stabiliser cylinders' foot axle (2 lubricators).
- 19 - Lubricators of the stabiliser cylinders' head axle (2 lubricators).
- 20 - Lubricators of the stabiliser axles (2 lubricators).

#### **SINGLE SIDE-SHIFT CARRIAGE (TSDL) (OPTION)**

- 21 - Wear plate lubricators (8 lubricators).



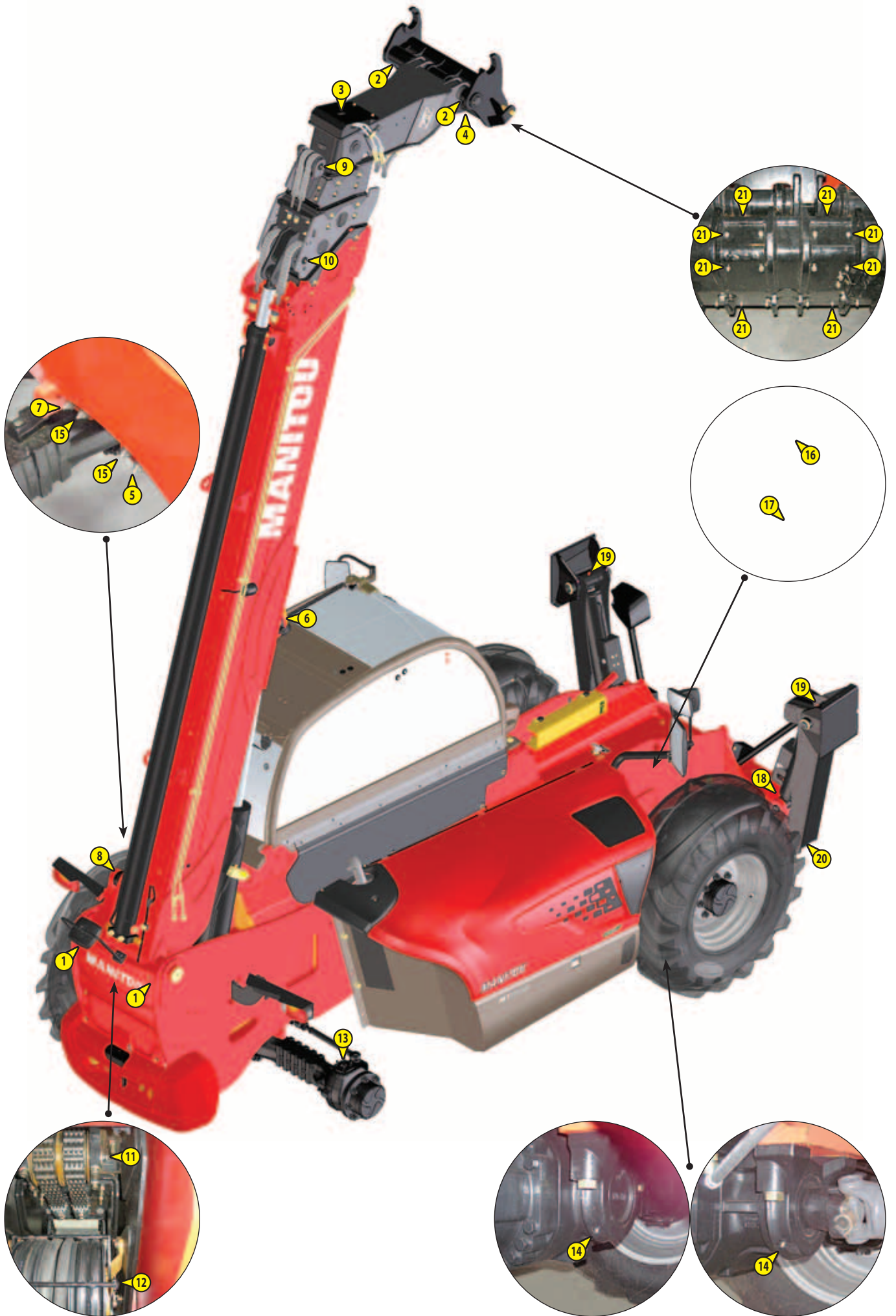

## B6 – HYDRAULIC OIL LEVEL

CHECK

Place the lift truck on level ground with the engine stopped, and the boom retracted and lowered as far as possible.

### ⚠ IMPORTANT ⚠

*Use a clean funnel and clean the underside of the oil drum before filling.*

- Check dipstick 1, the correct level must stand at the level of the red point.
- If necessary, add oil (see: 3 - MAINTENANCE: LUBRICANTS AND FUEL).
- Remove the protective casing 2.
- Remove cap 3.
- Add oil through filler port 4.
- Refit the cap.
- Visually check that there is no leakage in the tank and pipes.
- Refit the protective casing.

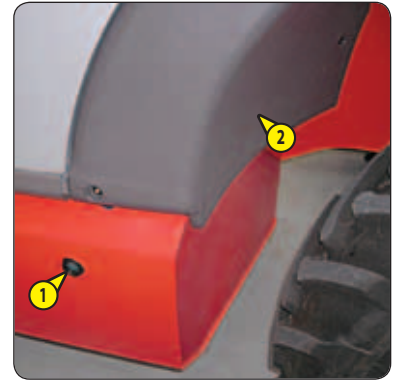

## B7 – BRAKE OIL LEVEL

CHECK

Place the lift truck on level ground.

### ⚠ IMPORTANT ⚠

*If the brake oil level is abnormal consult your dealer.*

- Open the protective casing 1 with the ignition key.
- Check tank 2. The level is correct when it is situated at the MAX level on the tank.
- If necessary, add oil (see: 3 - MAINTENANCE: LUBRICANTS AND FUEL).
- Remove cap 3.
- Add oil through filler port 4.
- Refit the cap.
- Visually check that there is no leakage in the tank and pipes.



## B8 – WINDSCREEN WASHER LIQUID LEVEL

CHECK

- Visually check the level in tank 1.
- If necessary add windscreen washer liquid (see: 3 - MAINTENANCE: LUBRICANTS AND FUEL).
- Remove cap 2.
- Add windscreen washer liquid through filler port 3.
- Refit the cap.



## B9 – CAB VENTILATION FILTERS

CLEAN

### EXTERNAL CAB VENTILATION FILTER

- Take out the cab ventilation filter 1.
- Clean the filter with a compressed air jet.
- Check its condition and change if necessary (see: 3 - MAINTENANCE: FILTERS CARTRIDGES AND BELTS).
- Reinstall the filter.
- Refit the protective casing 2.



### INTERNAL CAB VENTILATION FILTER

- Remove the protective grid 3.
- Lift out cab ventilation filter 4.
- Clean the filter with a compressed air jet.
- Check its condition and change if necessary (see: 3 - MAINTENANCE: FILTERS CARTRIDGES AND BELTS).
- Reinstall the filter.
- Refit the protective grid 3.



## B10 – CONDENSER CORE (AIR-CONDITIONING OPTION)

CHECK - CLEAN

### ⚠ IMPORTANT ⚠

*In a polluting atmosphere, clean the radiator core every day.*

*Do not use a water jet or high-pressure steam as this could damage the condenser fins.*

- Visually check whether the condenser is clean and clean it if necessary.
- Clean the condenser using a compressed air jet aimed in the same direction as the air flow.
- Clean with the fans running for best results.



## C - EVERY 250 HOURS OF SERVICE

Carry out the operations described previously as well as the following operations.

### C1 - OUTER BOOM CHAINS

CLEAN - GREASE - CHECK

MT 1840 ...

#### ⚠ IMPORTANT ⚠

These checks are important for the proper operation of the boom. In case of technical faults, consult your dealer.

#### CLEAN AND GREASE

- Set the lift truck on its stabilisers, with the boom horizontal.
- Fully extend the telescopes.
- Protect the underside of the telescopes.
- Wipe the outer boom chains 1 with a clean, lint-free cloth, then examine them closely so as to detect any signs of wear.
- Vigorously brush the chains to get rid of any foreign matter, with a hard nylon brush and clean diesel fuel.
- Rinse the chains by means of a paint brush impregnated with clean diesel fuel and dry them with a compressed air jet.
- Lightly lubricate the chains (see: 3 - MAINTENANCE: LUBRICANTS AND FUEL), and perform a number of telescoping movements to check the behaviour of the chains.

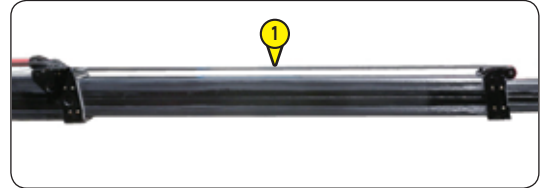
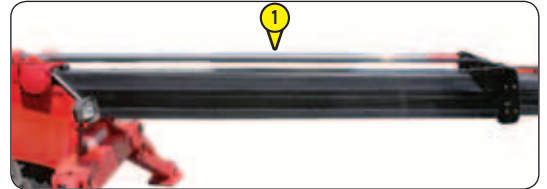

#### CHECK THE TENSION

- Fully extend the telescopes, then retract the boom 200 mm.
- At the centre of both telescopes (T1) and (T2), use a ruler to measure the perpendicular distance between the top of the telescope and the underside of the chain, this distance must be identical for both chains.
  - Telescope (T1): between 117 mm and 97 mm
  - Telescope (T2): between 85 mm and 65 mm



### C2 - CAB VENTILATION FILTERS

CHANGE

#### EXTERNAL CAB VENTILATION FILTER

- Remove protective casing 1 using the ignition key.
- Lift out cab ventilation filter 2 and replace it with a new one (see: 3 - MAINTENANCE: FILTERS, CARTRIDGES AND BELTS).
- Refit the protective casing.



#### INTERNAL CAB VENTILATION FILTER

- Remove the protective grid 3.
- Lift out cab ventilation filter 4 and replace it with a new one (see: 3 - MAINTENANCE: FILTERS, CARTRIDGES AND BELTS).
- Refit the protective grid.



### **C3 – FRONT AND REAR AXLE DIFFERENTIAL OIL LEVEL**

**CHECK**

Place the lift truck on level ground with the engine stopped.

- Remove the level plug 1; the oil should be flush with the edge of the hole.
- If necessary, add oil (see: 3 - MAINTENANCE: LUBRICANTS AND FUEL) through the filler port 2.
- Refit and tighten the level plug 1 (tightening torque 34 to 49 N.m).

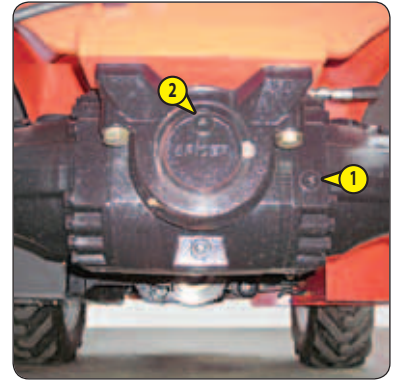

### **C4 – FRONT AND REAR WHEEL REDUCTION GEAR OIL LEVEL**

**CHECK**



Place the lift truck on level ground with the engine stopped.

- Check the level on each wheel reduction gear.
- Place level plug 1 in a horizontal position.
- Remove the level plug; the oil should be flush with the edge of the opening.
- If necessary, add oil (see: 3 - MAINTENANCE: LUBRICANTS AND FUEL) through the same opening.
- Refit and tighten the level plug (tightening torque 34 to 49 N.m).

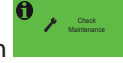

## D - EVERY 500 HOURS OF SERVICE OR EVERY YEAR

Carry out the operations described previously as well as the following operations.

A maintenance warning is displayed at 480 hours on the help screen  followed by a 20 hour countdown to reach the 500 hour maintenance deadline. After this period, the help screen  is displayed, followed by the maintenance key . The maintenance then has to be performed.

NOTE: Once this maintenance has been performed (D - EVERY 500 HOURS OF OPERATION, reset the maintenance counter to 500 hours from the "XPRT > RESET > MAINT" menu in the menu screen.

### D1 - ENGINE OIL

DRAIN

### D2 - ENGINE OIL FILTER

REPLACE

Place the lift truck on level ground, let the engine run at idle for a few minutes, then stop the engine.

**⚠ IMPORTANT ⚠**

**USE THE RECOMMENDED LUBRICANTS: "API CI-4; ACEA E9"**

*Dispose of used oil in an ecological manner.*

#### DRAINING THE OIL

- Open engine bonnet and the lower cover.
- Remove access panel 1.
- Place a container under the drain port and unscrew the drain plug 2.
- Take drain hose 3.
- Place the end of the drain hose in the container and screw the hose fully to the drain connector 2.
- Remove the filling plug 4 to ensure that the oil is drained properly.

#### REPLACEMENT OF THE FILTER

- Unscrew and discard the engine oil filter 5, together with its seal.
- Clean the filter holder with a clean, lint-free cloth.
- Lightly grease the new seal before refitting the new oil filter (see: 3 - MAINTENANCE: FILTERS, CARTRIDGES AND BELTS) on its bracket (tightening torque 15-17 N.m).

#### FILLING UP THE OIL

- Remove, clean and refit drain hose 3.
- Refit and tighten the drain plug 2.
- Fill up with oil (see: 3 - MAINTENANCE: LUBRICANTS AND FUEL) through filler port 4.
- Wait a few minutes to allow the oil to flow into the sump.
- Start the engine and let it run for a few minutes.
- Check for possible leaks from the drain plug and the oil filter.
- Stop the engine, wait a few minutes and check the correct level between the two level marks on the dipstick 6.
- Top up the level if necessary.
- Refit access panel 1.

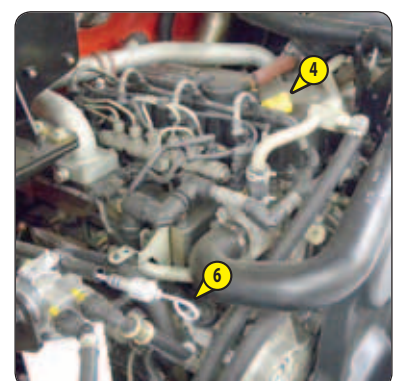
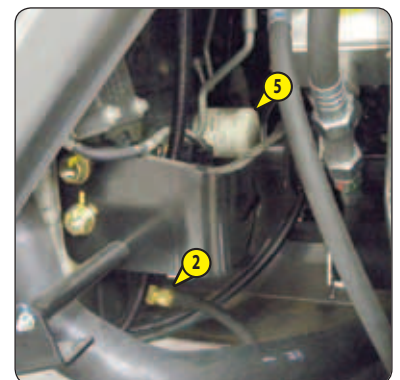

### D3 – ALTERNATOR/FAN/CRANKSHAFT BELT TENSION

CHECK - ADJUST

**⚠ IMPORTANT ⚠**

*If the compressor belt has to be changed, check the tension again after the first 20 hours of operation.*

- Open the engine bonnet.
- Remove the protective casing 1.
- Check the belt for signs of wear and cracks and change if necessary (see: 3 - MAINTENANCE: FILTERS CARTRIDGES AND BELTS).
- Check the belt tension between the crankshaft and alternator pulleys.
- Under a normal pressure exerted with the thumb (45 N), the belt should move approximately 10 mm.
- Adjust if necessary.
- Loosen the screws 2 and 3 by two to three thread turns.
- Tighten the screw 4 to tighten the belt to the tension required.
- Re-tighten the screws 2 (tightening torque 30 N.m) and the screw 3 (tightening torque 42 N.m).
- Refit the protective casing 1.

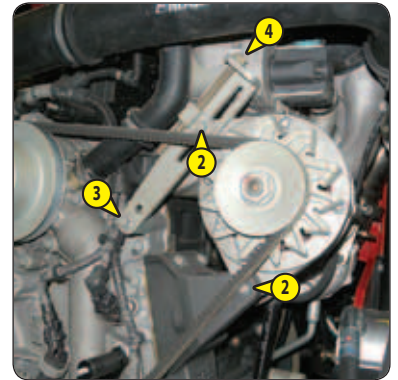

### D4 – COMPRESSOR BELT TENSION (AIR-CONDITIONING OPTION)

CHECK - ADJUST

**⚠ IMPORTANT ⚠**

*If the compressor belt has to be changed, check the tension again after the first 20 hours of operation.*

- Open the engine bonnet.
- Lower the bottom cover (OPTION).
- Remove the protective casing 2.
- Check the belt for signs of wear and cracks and change if necessary (see: 3 - MAINTENANCE: FILTERS CARTRIDGES AND BELTS).
- Check the belt tension between the pulleys of the crankshaft and of the compressor.
- Under a normal pressure exerted with the thumb (45 N), the belt should move approximately 10 mm.
- Adjust if necessary.
- Loosen screws 3 by two to three turns.
- Swivel the compressor assembly so as to obtain the belt tension required.
- Retighten screws 3 (tightening torque 22 N.m).

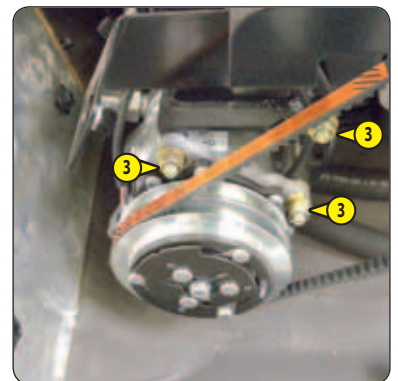
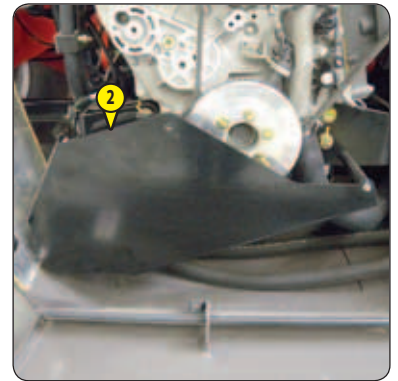

## D5 – HYDRAULIC RETURN OIL FILTER CARTRIDGE

REPLACE

Stop the engine and release the pressure from the systems by operating the hydraulic control.

### ⚠ IMPORTANT ⚠

*Thoroughly clean the outside of the filter and its surroundings before any operation to prevent any risk of polluting the hydraulic system.*

- Remove the protective casing 1.
- Remove the filler plug 2 and unscrew cover 3 by two or three thread turns.
- Wait a few moments while the oil flows into the tank.
- Remove the cover and slowly take out filter cartridge assembly 4.
- Place the assembly in a clean container.
- Pinch the head 5 and separate it from the tank 6.
- Replace the cartridge 7 with a new one (see: 3 - MAINTENANCE: FILTERS CARTRIDGES AND BELTS).
- Put back the assembly then retighten the cover.
- Refit the filler plug 2.
- Refit the protective casing 1.



## D6 – HYDRAULIC OIL

CHECK

MANITOU offers a hydraulic oil analysis kit which might make it possible to delay the recommended deadline in the maintenance table (2000 hours). In this case we recommend an analysis of the hydraulic oil every 500 hours of operation.

The oil analysis kit also makes it possible to confirm the oil quality so as to obtain a deadline of 2000 hours for specific uses causing constraints on the hydraulic circuit: extreme environmental conditions, use of the attachments with a very high hydraulic flow rate (such as a sweeper, or a concrete mixer).

**MANITOU oil analysis kit Part No. 958162.**





## D7 – FRONT AND REAR AXLE DIFFERENTIAL OIL

### DRAIN

Place the lift truck on level ground with the engine stopped and the still warm differential oil.

#### **⚠ IMPORTANT ⚠**

*Dispose of the drain oil in an ecological manner.*

- Place a container under the drain plugs 1 and unscrew them.
- Remove level plug 2 and filling plug 3 to ensure that the oil is drained properly.
- Refit and tighten the drain plugs 1 (tightening torque 34 to 49 N.m).
- Fill up with oil (see: 3 - MAINTENANCE: LUBRICANTS AND FUEL) through filler port 3.
- The level is correct when the oil level is flush with the edge of opening 2.
- Check for any possible leaks at the drain plugs.
- Refit and tighten level plug 2 (tightening torque 34 to 49 N.m) and filler plug 3 (tightening torque 34 to 49 N.m).
- Repeat this operation for the rear axle differential.

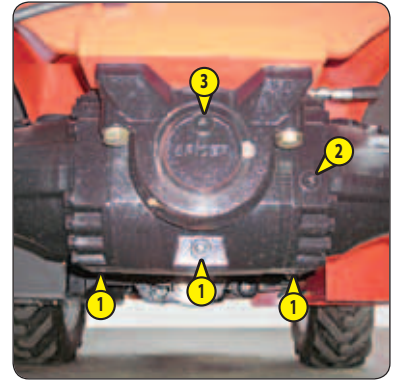

## E - EVERY 1000 HOURS OF SERVICE OR TWO YEARS

Carry out the operations described previously as well as the following operations.

### E1 – DRY AIR FILTER CARTRIDGE

REPLACE

In case of use in a heavily dust laden atmosphere, there are pre-filtration cartridges, see: 3 - MAINTENANCE: FILTERS CARTRIDGES AND BELTS. Also, the checking and cleaning periodicity of the cartridge must be reduced (up to 250 hours in a heavily laden dust atmosphere and with pre-filtration).

#### ⚠ IMPORTANT ⚠

*Change the cartridge in a clean location, with the engine stopped. Never operate the lift truck with the air filter removed or damaged.*

- Open the engine bonnet.
- Loosen the bolts and remove cover 1.
- Gently remove the cartridge 2 taking care to avoid spilling the dust.
- Leave the safety cartridge in place.
- Carefully clean the following parts with a damp, clean lint-free cloth.
  - The inside of the filter and cover.
  - The inside of the filter inlet hose.
  - The gasket surfaces in the filter and in the cover.
- Check pipes and connections between the air filter and the engine and the connection and state of the clogging indicator on the filter.
- Before mounting check the condition of the new cartridge (see: 3 - MAINTENANCE: FILTERS CARTRIDGES AND BELTS).
- Insert the cartridge in the filter axis and push it home, pressing against the outer edge and not the center.
- Reassemble the cover, guiding the valve downwards.

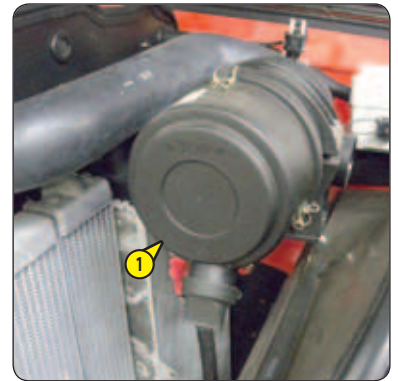

### E2 – FUEL PRE-FILTER

REPLACE

#### ⚠ IMPORTANT ⚠

*Carefully clean the outside of the pre-filter and its holder, to prevent dust from getting into the system.*

*Tighten the fuel filter by hand only and lock in place by a quarter turn.*

- Switch off the lift truck's ignition.
- Open the engine bonnet.
- Disconnect electrical wiring harness 1 from the fuel pre-filter.
- Place a receptacle under the drain plug 2 and unscrew by two to three turns.
- Open bleed screw 3 to ensure proper emptying.
- Re-tighten bleed screw 3 once the pre-filter is emptied.
- Loosen pre-filter 4 and discard it, together with its seal.
- Clean the inside of the pre-filter head using a brush immersed in clean diesel oil.
- Refit a pre-filter and a new seal lubricated with clean diesel beforehand (see: 3 - MAINTENANCE: FILTERS CARTRIDGES AND BELTS).
- Reconnect the fuel pre-filter wiring harness 1.
- Replace the fuel filter.

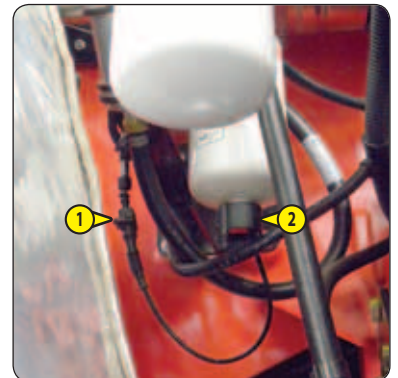

### E3 – FUEL FILTER

REPLACE

#### ⚠ IMPORTANT ⚠

*Carefully clean the outside of the filter and its holder, to prevent dust from getting into the system.*

- Unscrew and discard the fuel filter 1.
- Clean the inside of the filter head using a brush immersed in clean diesel oil.
- Refit a filter and a new seal lubricated with clean diesel beforehand (see: 3 - MAINTENANCE: FILTERS CARTRIDGES AND BELTS).
- Tighten the filter, making sure that the seal is correctly positioned (tightening torque 10-12 N.m).
- Open the bleed screw 3 of the fuel pre-filter and the bleed screw 2 of the fuel filter.
- Switch on the lift truck's ignition, and close the bleed screw as soon as the diesel flows with no air.



### E4 – FUEL TANK

CLEAN

### E5 – FUEL TANK BREATHER

REPLACE

Place the lift truck on level ground with the engine stopped.

#### ⚠ IMPORTANT ⚠

*Do not smoke or approach with a flame during this operation.*

*Never attempt to carry out welding or any other operation by yourself, as this could cause an explosion or a fire.*

- Inspect the parts of the fuel circuit and the tank liable to leak, both visually and by touch.
- In the event of a leak, contact your dealer.
- Place a container under drain plug 1 and unscrew the plug.
- Remove the filling plug 2 to ensure that the oil is drained properly.
- Rinse out with ten liters of clean diesel through filler port 3.
- Refit and tighten the drain plug (tightening torque 72 to 88 N.m).
- Open storage compartment 4.
- Unscrew the breather 5 and replace with a new one (see: 3 - MAINTENANCE: FILTERS CARTRIDGES AND BELTS) (tightening torque  $5 \pm 2$  N.m).
- Fill the fuel tank with clean diesel filtered through the filler port.
- Refit the filler plug.

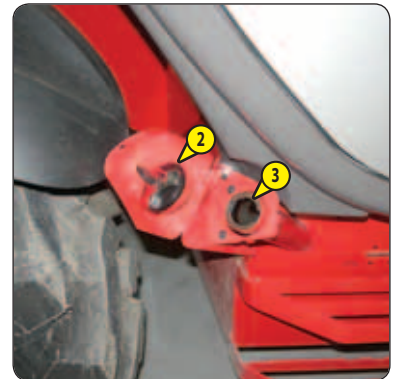
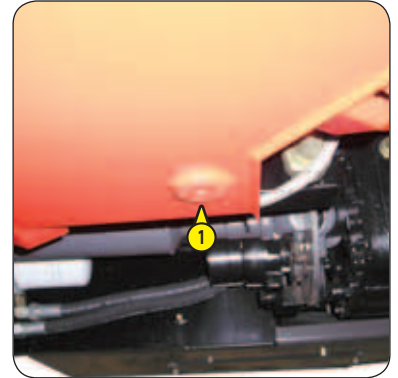

## E6 – ALTERNATOR/FAN/CRANKSHAFT BELT

REPLACE

### ⚠ IMPORTANT ⚠

*If the alternator belt has to be changed, check the tension again after the first 20 hours of operation.*

- Open the engine bonnet.
- Remove the protective casing 1.
- Loosen the screws 2 and 3 by two to three thread turns.
- Loosen the screw 4 to swivel the alternator assembly so as to free the belt 5.
- Remove the belt and replace with a new one (see: 3 - MAINTENANCE: FILTER ELEMENTS AND BELTS).
- Adjust the belt tension between the crankshaft and alternator pulleys.
- Tighten the screw 4 to tighten the belt to the tension required.
- Under a normal pressure exerted with the thumb (45 N), the belt should move approximately 10 mm.
- Re-tighten the screws 2 (tightening torque 30 N.m) and the screw 3 (tightening torque 42 N.m).
- Refit the protective casing 1.

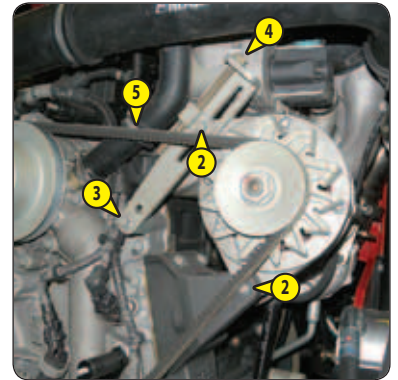
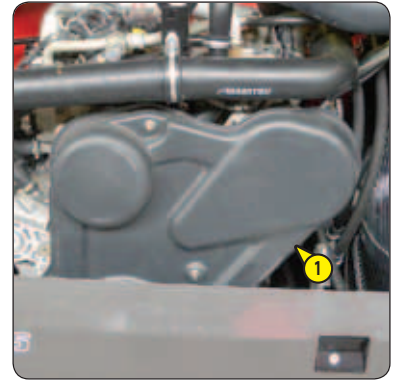

## E7 – GEAR BOX OIL

DRAIN

## E8 – GEAR BOX OIL FILTER

REPLACE

Place the lift truck on level ground with the engine stopped and the gear box oil still warm.

### ⚠ IMPORTANT ⚠

*Dispose of the waste oil in an ecological manner.  
Hand-tighten the oil filter and lock in place with a quarter turn.*

### ⚠ IMPORTANT ⚠

*Raise the boom and place the boom safety wedge on the rod of the lifting cylinder (see: 1 - OPERATING AND SAFETY INSTRUCTIONS: LIFT TRUCK MAINTENANCE INSTRUCTIONS).*

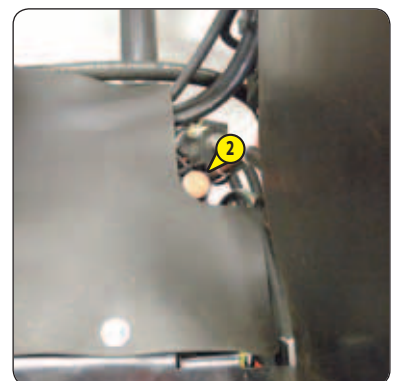

### DRAINING THE OIL

- Place a container under drain plug 1 and unscrew the plug.
- Remove gauge 2 to ensure proper emptying.

### REPLACEMENT OF THE FILTER

- Unscrew and discard gear box oil filter 3, together with its seal.
- Clean the filter holder with a clean, lint-free cloth.
- Lightly grease the new seal before refitting the new oil filter (see: 3 - MAINTENANCE: FILTERS, CARTRIDGES AND BELTS) on its bracket.

### FILLING UP THE OIL

- Refit and tighten the drain plug 1 (tightening torque 34 to 54 N.m).
- Fill up with oil (see: 3 - MAINTENANCE: LUBRICANTS AND FUEL) through filler port 2.
- Start the engine and leave it at idle.
- Check for possible leaks from the drain plug and the oil filter.
- Check the correct level against the MAX mark on the dipstick 2.
- Top up the level if necessary.



MT 1840 ...

- Chain wear occurs at a number of locations.
  - On the joints, which leads to elongation of the chain.
  - On the edge of link plates through contact with the pulleys.
  - On the sides of the plates and the protruding pins through contact with the pulley flanges.
  - On the alignment of the flats of the extended pins.

**CHAIN ELONGATION**

We recommend that you perform this operation using the chain checking gauge (MANITOU part No.: 161583).



- Set the lift truck on its stabilizers, with the boom horizontal.
- Fully extend the telescopes and continue operating the control for a few moments to properly tension the chains.
- As the chain will likely wear unevenly over its length, divide the chain into 4 equal sections and check with the gauge at the center of each section.

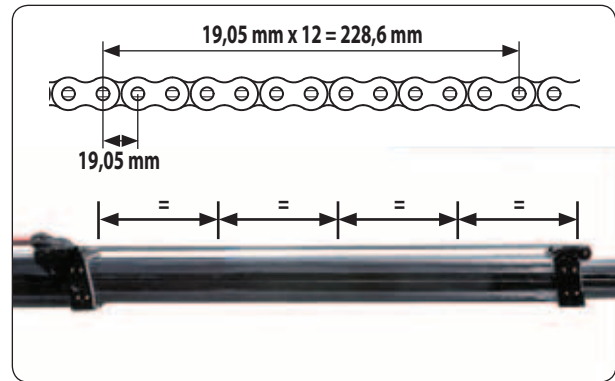
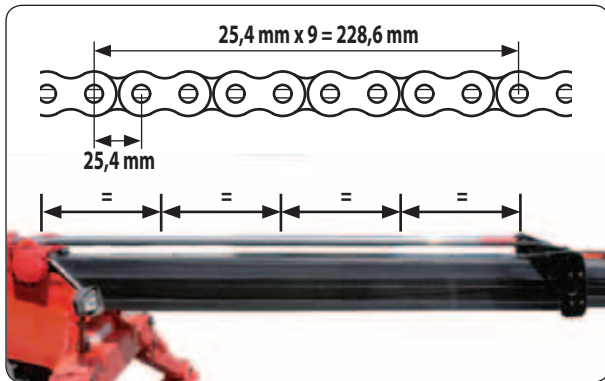

**⚠ IMPORTANT ⚠**

*If the maximum dimension is exceeded ( $228,6 \text{ mm} + 2\% = 233,2 \text{ mm}$ ), replace the pair of chains (contact your dealer).*

**PLATE EDGE WEAR**

As for chain elongation, perform a check in the middle of each equal section using a caliper gage.

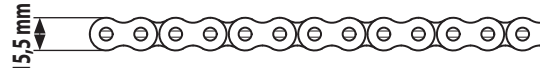

**⚠ IMPORTANT ⚠**

*Above the minimum dimension ( $24 \text{ mm} - 2\% = 23,5 \text{ mm}$  and  $15,5 \text{ mm} - 2\% = 15,2 \text{ mm}$ ), replace the pair of chains (contact your dealer).*

**EXTENDED PIN WEAR**

As for chain elongation, perform a check in the middle of each equal section using a caliper gage.

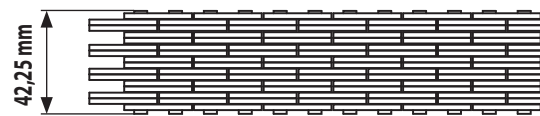

**⚠ IMPORTANT ⚠**

*Above the minimum dimension ( $53,6 \text{ mm} - 2\% = 52,5 \text{ mm}$  and  $42,25 \text{ mm} - 2\% = 41,4 \text{ mm}$ ), replace the pair of chains (contact your dealer).*

- In addition to wear, the high pressures between the side of the plates and the pulleys may force out material, causing the joints to seize. Replace the pair of chains in this case also.

**ALIGNMENT OF EXTENDED PIN FLATS**

Check the chains over their entire length.

- High friction between the plates and the extended pins may cause the pins to turn within the outer plates and thus come out of their housing.



**⚠ IMPORTANT ⚠**

*If the flats are not aligned in the longitudinal direction of the chain, replace the pair of chains (contact your dealer).*

**⚠ IMPORTANT ⚠**

*In no event should the lift truck be used if the seat belt is defective (fixing, locking, cuts, tears, etc.).  
Repair or replace the seat belt immediately.*

## SEAT BELT WITH TWO ANCHORING POINTS

- Check the following points:
  - Fixing of the anchoring points on the seat.
  - Cleanness of the strap and the locking mechanism.
  - Triggering of the locking mechanism.
  - Condition of the strap (cuts, curled edges).

## REELED SEAT BELT WITH TWO ANCHORING POINTS

- Check the points listed above together with the following points:
  - The correct winding of the belt.
  - Condition of the reel guards.
  - Roller locking mechanism when the strap is given a sharp tug.

NOTE: After an accident, replace the seat belt.

**E11 – FRONT AND REAR WHEEL REDUCTION GEAR OIL****DRAIN**

Place the lift truck on level ground with the engine stopped and the reducers' oil still warm.

**⚠ IMPORTANT ⚠**

*Dispose of the drain oil in an ecological manner.*

- Drain and change the oil of each wheel reduction gear.
- Place drain plug 1 in position A.
- Place a container under the drain plug and unscrew the plug.
- Let the oil drain fully.
- Place the drain port in position B, i.e. in a level port.
- Fill up with oil (see: 3 - MAINTENANCE: LUBRICANTS AND FUEL) through level port 1.
- The level is correct when the oil level is flush with the edge of the hole.
- Refit and tighten the drain plug (tightening torque 34 to 49 N.m).

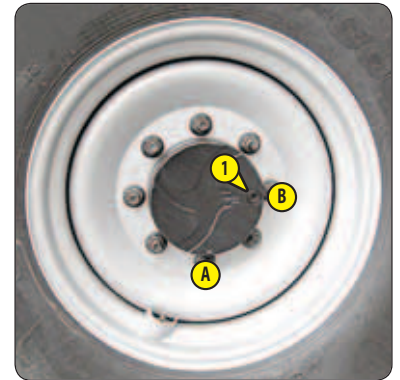



## F - EVERY 2000 HOURS OF SERVICE OR EVERY TWO YEARS

Carry out the operations described previously as well as the following operations.

### F1 - COOLING LIQUID

**DRAIN**

These operations are to be carried out as necessary or every two years at the beginning of winter. Place the lift truck on level ground with the engine stopped and cold.

#### **⚠ IMPORTANT ⚠**

*The engine does not contain any corrosion resistor and must be filled throughout the year with a mixture containing 25% ethylene glycol-based antifreeze.*

#### **DRAINING THE LIQUID**

- Open the engine bonnet.
- Remove access panel 1.
- Place a container under the radiator drain plug 2.
- Remove filler plug 3 from the expansion tank and fully open the heating control to ensure proper emptying.
- Let the cooling circuit drain entirely while ensuring that the ports do not get clogged.
- Check the condition of the hoses as well as the fastening devices and change the hoses if necessary.
- Rinse the circuit with clean water and use a cleaning agent if necessary.

#### **FILLING THE LIQUID**

- Close the drain valve 2.
- Slowly fill the circuit with cooling liquid through the filler port (see: 3 - MAINTENANCE: LUBRICANTS AND FUEL) up to the middle of the expansion tank 4.
- Refit the filler plug 3.
- Run the engine at idle for a few minutes.
- Check for any possible leaks.
- Refit access panel 1.
- Check the level and refill if necessary.

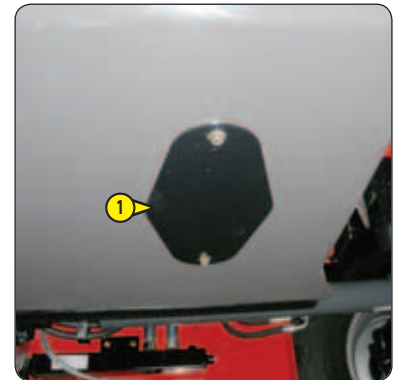

### F2 - SAFETY DRY AIR FILTER CARTRIDGE

**REPLACE**

- For the disassembly and reassembly of the dry air filter cartridge, see: 3 - MAINTENANCE: E1 - AIR FILTER CARTRIDGE.
- Gently remove the dry air filter safety cartridge 1, taking care to avoid spilling the dust.
- Clean the gasket surface on the filter with a damp, clean lint-free cloth.
- Check the condition of the new safety cartridge before fitting (see: 3 - MAINTENANCE: FILTERS AND BELTS).
- Insert the cartridge in the filter axis and push it home, pressing against the outer edge and not the center.

#### **⚠ IMPORTANT ⚠**

*The safety cartridge replacement frequency is given for information only. It must be changed every second time the dry air filter cartridge is changed.*

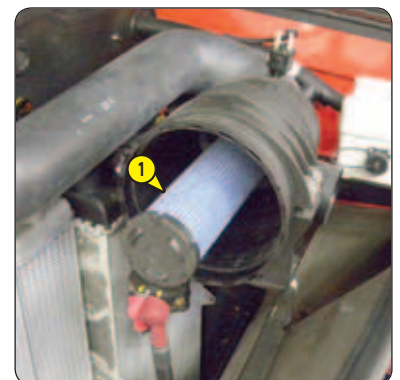

### F3 - WHEEL NUT TIGHTENING TORQUES

**CHECK**

- Check the condition of the tyres, to detect cuts, blisters, wear, etc.
- Check the tightening torque of the wheel nuts with a torque wrench.
  - Front tyres: 630 N.m ± 15 %
  - Rear wheels: 630 N.m ± 15%



## F4 – HYDRAULIC OIL

DRAIN

## F5 – BREATHER FOR THE HYDRAULIC OIL TANK

REPLACE

## F6 – SUCTION STRAINER FOR HYDRAULIC OIL TANK

CLEAN

## F7 – BRAKE ACCUMULATOR UNIT FILTER

REPLACE

Place the lift truck on level ground with the engine stopped, and the boom retracted and lowered as far as possible.

### ⚠ IMPORTANT ⚠

*Before any intervention, thoroughly clean the area surrounding the drain plug and the suction strainer on the hydraulic tank.  
Use a clean container and funnel and clean the top of the oil drum before filling.  
Dispose of the drain oil in an ecological manner.*

### DRAINING THE OIL

- Remove the protective casing 1.
- Place a container under drain plug 2 and unscrew the plug.
- Remove the filling plug 3 to ensure that the oil is drained properly.

### REPLACING THE BREATHER

- Unscrew the breather 4 and replace it with a new one (see: 3 - MAINTENANCE: FILTERS, CARTRIDGES AND BELTS).

### CLEANING THE STRAINER

- Disconnect hose 5.
- Remove and clean the suction strainer 6 using a compressed air jet, check its condition and replace if necessary (see: 3 - MAINTENANCE: FILTERS CARTRIDGES AND BELTS).
- Refit the suction strainer making sure the seal is in the correct position.

### REPLACING THE BRAKE ACCUMULATOR UNIT FILTER

- Unscrew plug 7, remove the filter and replace with a new one.
- Refit and tighten plug 7 (tightening torque 70 to 80 N.m).

### FILLING UP THE OIL

- Refit and tighten the drain plug 2 (tightening torque 72 to 88 N.m).
- Fill up with oil (see: 3 - MAINTENANCE: LUBRICANTS AND FUEL) through filler port 8.
- Observe the oil level on dipstick 9, the oil level should be at the level of the red point.
- Check for any possible leaks at the drain plug.
- Refit the filler plug 3.

### HYDRAULIC CIRCUIT DECONTAMINATION

- Let the engine run (accelerator pedal at mid position) for 5 minutes without using any accessories on the lift truck, then for 5 more minutes while using all the hydraulic movements (except the steering system and the service brakes).
- Accelerate the engine at full speed for 1 minute, then activate the steering system and the service brakes.
- This operation makes a pollution abatement of the circuit possible through the hydraulic return oil filter.

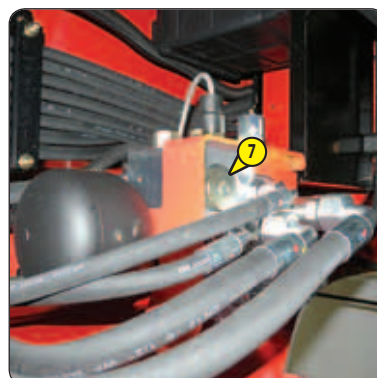
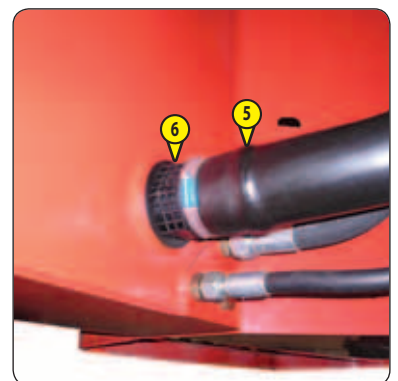
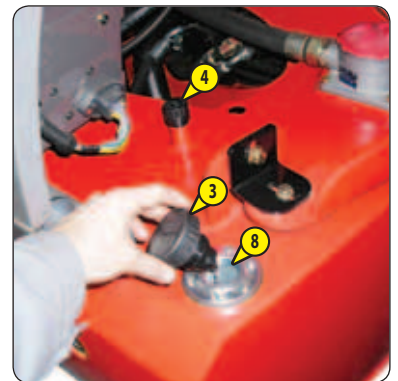
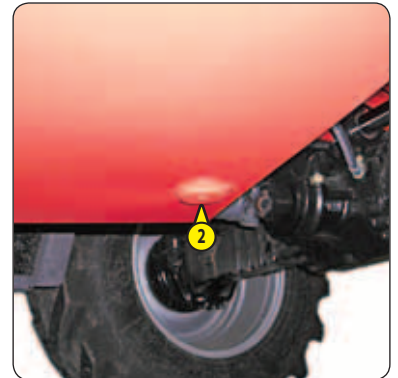

**CLEANING CONDENSER AND EVAPORATOR COILS (\*)**

**CLEANING CONDENSATE TRAY AND RELIEF VALVE (\*)**

**COLLECTING COOLANT TO REPLACE FILTER-DRIER (\*)**

**REFILLING WITH COOLANT AND CHECKING THE THERMOSTATIC CONTROL AND PRESSURE SWITCHES (\*)**

NOTE: When opening the evaporator unit, remember to replace the cover seal.

(\*): (CONSULT YOUR DEALER).

**⚠ IMPORTANT ⚠**

**DO NOT ATTEMPT TO REPAIR ANY FAULTS BY YOURSELF. ALWAYS REFER TO YOUR DEALER WHEN REFILLING CIRCUITS, AS THEY HOLD THE CORRECT SPARE PARTS, AS WELL AS HAVING THE NECESSARY TECHNICAL KNOWLEDGE AND TOOLS.**

*In the event of inhalation, take the victim into fresh air, give oxygen or artificial respiration if necessary and call a doctor.*

*In the event of contact with the skin, wash immediately with copious amounts of water and remove any contaminated garments.*

*In the event of contact with the eyes, rinse with clear water for 15 minutes and call a doctor.*

- Do not open the circuit under any circumstances as this would loss of coolant.
- The cooling circuit contains a gas which can be dangerous under certain conditions. This gas, coolant R-134a, is colorless, odorless and heavier than air.
- The compressor has a fluid level gauge; never unscrew this gauge because it would depressurise the system. The fluid level should only be checked when draining the system.





## G - OCCASIONAL MAINTENANCE

### G1 - WHEEL

#### CHANGE

For this operation, we advise you to use the hydraulic jack MANITOU reference 505507 and the safety support MANITOU reference 554772.

#### **⚠ IMPORTANT ⚠**

*In the event of a wheel being changed on the public highway, secure the lift truck vicinity:*

- Stop the lift truck, if possible on firm, level ground.
- Shut down the lift truck (see: 1 - OPERATING AND SAFETY INSTRUCTIONS: DRIVING INSTRUCTIONS UNLADEN AND LADEN).
- Switch on the hazard warning lights.
- Immobilise the lift truck in both directions on the axle opposite to the wheel to be changed.
- Loosen the nuts of the wheel to be changed.
- Place the jack under the flared axle tube, as near as possible to the wheel and adjust the jack.
- Raise the wheel until it is clear of the ground and place the safety support under the axle.
- Completely unscrew the wheel nuts and remove them.
- Free the wheel by reciprocating movements and roll it to the side.
- Slip the new wheel on the wheel hub.
- Hand-tighten the nuts, grease them if necessary.
- Remove the safety support and lower the lift truck with the jack.
- Tighten the wheel nuts with a torque wrench (see: 3 - MAINTENANCE: A - DAILY OR EVERY 10 HOURS OF SERVICE for tightening torque).



According to the use of the lift truck, the device may require to be periodically reset. This procedure simplifies the operation.



**⚠ IMPORTANT ⚠**

*Scrupulously follow the boom positioning instructions.*













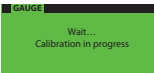
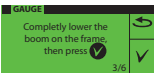

*The appearance of the screen  indicates a failure to obey an instruction, a cancellation request or a late response. If in doubt, contact your dealer.*

**When the reset is completed, check the operation of the longitudinal stability limiter and warning device (see: 3 - MAINTENANCE: A - DAILY OR EVERY 10 HOURS SERVICE).**

- Provide a fork carrier or a bucket and a load corresponding to at least half the lift truck's rated capacity.
- Preferably perform the reset when the lift truck is still cold (before it is used) or ensure that the temperature of the rear axle is not more than 50°C.
- Place the lift truck on flat, level ground with the wheels straight.

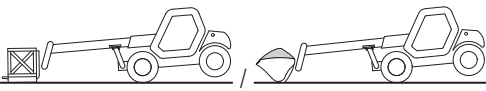
- Display the GAUGE "reset strain gauge" menu  (see: 2 - DESCRIPTION: 6D - SCREEN DISPLAY: MENU SCREEN) and validate .

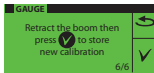
- Enter the CUSTOMER code  and validate .

<b>STAGE 1</b> ↓	   
	<p>- Fully extend the stabilisers.</p> <p>- Fully raise the boom with the telescopes fully retracted.</p>
<b>STAGE 2</b> ↓	
	<p>- Calibration in progress...</p>
<b>STAGE 3</b> ↓	   
	<p>- Fully lower the boom with the engine running at full revs and the hydraulic control at the maximum setting.</p> <p>- Fully raise the stabilisers.</p>
<b>STAGE 4</b> ↓	   <p><b>Wait 5 seconds and validate</b> </p>
	<p>- With the fork carriage or the bucket and a load. Boom fully retracted in the lowered position, approximately 20 centimetres from the ground.</p> <p><b>Keep the load as close to the ground as possible throughout this operation.</b></p> <p>- Hold down the disable the "aggravating" hydraulic movement cut-off button  (indicator lamp lit), and telescope the boom until the rear wheels leave the ground.</p>
<b>FINISH</b>	 
	<p>- Perform telescope retraction to restore the situation, then press the button  to record the new parameters.</p>

### G3 – FRONT HEADLIGHTS

#### ADJUSTING

#### RECOMMENDED SETTING

(as per standard ECE-76/756 76/761 ECE20)

Set to - 2% of the dipped beam in relation to the horizontal axis of the headlamp.

#### ADJUSTING PROCEDURE

- Place the unladen lift truck in the transport position and perpendicular to a white wall on flat, level ground.
- Check the tyre pressures (see: 2 - DESCRIPTION: FRONT AND REAR TYRES).
- Place the forward/reverse selector in neutral.

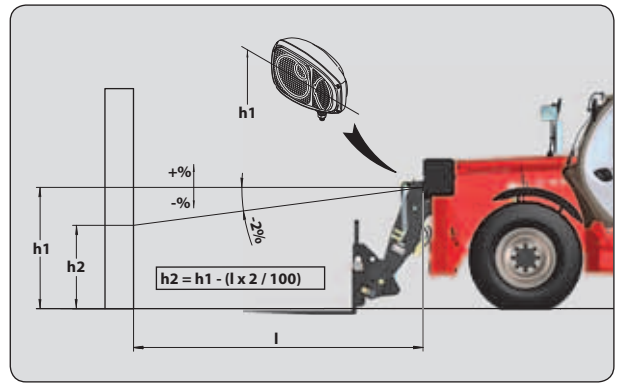

#### CALCULATING THE HEIGHT OF THE DIPPED BEAM (H2)

- h1 = Height of the dipped beam in relation to the ground.
- h2 = Height of the adjusted beam.
- l = Distance between the dipped beam and the white wall.

### G4 – BATTERY FAILURE

#### CHANGE

#### ⚠ IMPORTANT ⚠

*Operate the battery cut-out no less than 30 seconds after having switched off the ignition with the ignition key.*

*Handling and servicing a battery can be dangerous, take the following precautions:*

- Wear protective goggles.
- Keep the battery horizontal.
- Never smoke or work near a naked flame.
- Work in a well-ventilated area.

*- In the event of electrolyte being spilled onto the skin or splashed in the eyes, rinse thoroughly with cold water for 15 minutes and call a doctor.*

- Open the engine bonnet.
- Bring a floating battery of the same type as the one used for the lift truck and battery cables.
- Connect the floating battery while respecting the polarity (-) (+).
- Start the lift truck and remove the cables as soon as the engine is running.

#### ⚠ IMPORTANT ⚠

*Raise the boom and place the boom safety wedge on the rod of the lifting cylinder (see: 1 - OPERATING AND SAFETY INSTRUCTIONS: LIFT TRUCK MAINTENANCE INSTRUCTIONS).*

- Remove the protective casing 1.
- Change the battery 2.

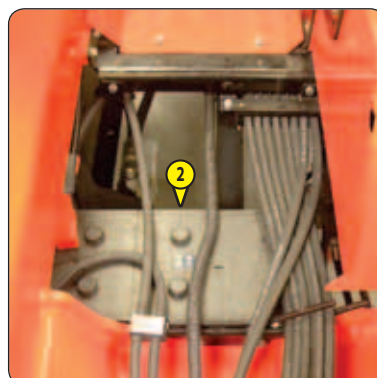
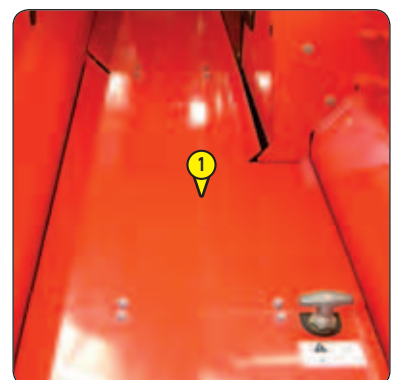
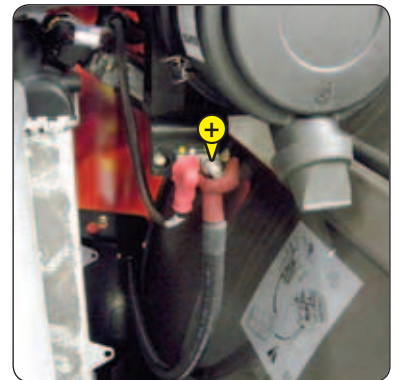
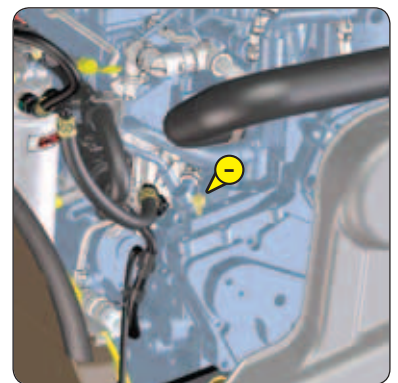

## G5 – LIFT TRUCK

### TOWING

#### ⚠ IMPORTANT ⚠

*Do not tow the lift truck at more than 6 km/h over a maximum distance of 5 km.*

*This manoeuvre is dangerous.*

*Carefully chock the lift truck before towing, as the parking brake system is inoperative.*

- Place the forward/reverse selection lever and gear shift lever in neutral.
- Chock the lift truck.
- Remove the cap 1.
- Loosen screw 2 with a pin wrench 3 to release the brake disk. Leave a minimum clearance of 5 mm between the disk 4 and the brake pads 5.
- Put the towing device into place.
- Remove the chocks.
- Switch on the hazard warning lights.

NOTE: Since there will be no steering or braking assistance, operate these controls slowly. Avoid sudden jerky movements.

#### ⚠ IMPORTANT ⚠

*For adjusting the parking brake, please contact your dealer.*

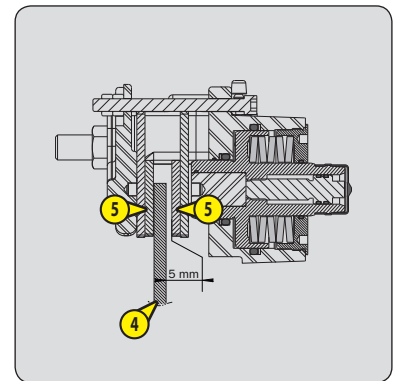
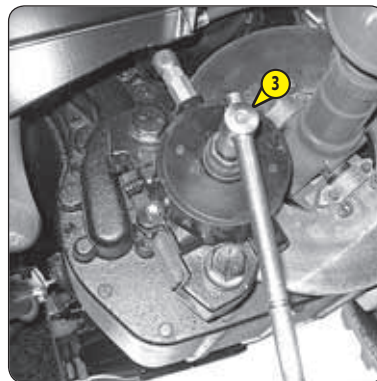
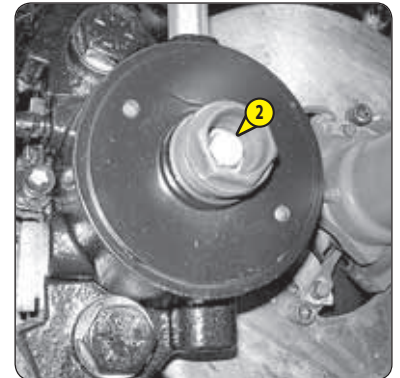
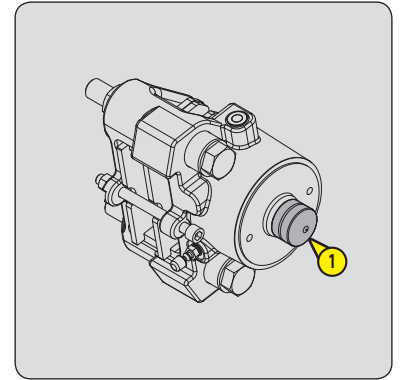

## G6 – LIFT TRUCK

### SLINGING

- Take into account the position of the lift truck centre of gravity for lifting.

A = 1340 mm      B = 1730 mm      MT 1435 ...

A = 1570 mm      B = 1500 mm      MT 1440 ...

A = 1620 mm      B = 1450 mm      MT 1840 ...

- Place the hooks in the fastening points 1 provided.

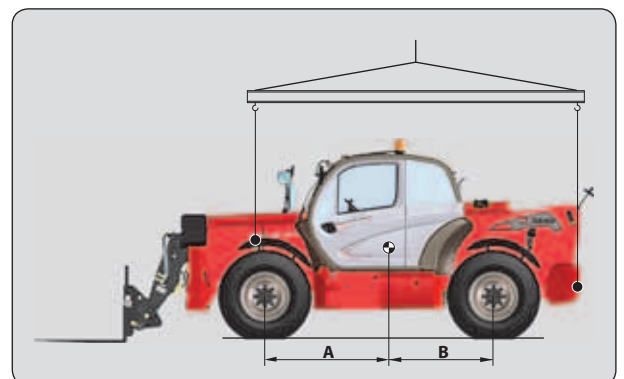

**⚠ IMPORTANT ⚠**

Ensure that the platform safety instructions are correctly applied before the loading of the lift truck and that the driver of the means of transport is informed about the dimensions and the weight of the lift truck (see: 2 - DESCRIPTION: CHARACTERISTICS).

Ensure that the platform is of sufficient size and load capacity for transporting the lift truck. Check also the allowable ground contact pressure of the platform relative to the lift truck.

**⚠ IMPORTANT ⚠**

For lift trucks equipped with a turbo-charged engine, block off the exhaust outlet to avoid rotation of the turbo shaft without lubrication when transporting the vehicle.

**LOADING THE LIFT TRUCK**

- Block the wheels of the platform.
- Attach the loading ramps to the platform in such a way as to give the shallowest possible ramp angle for the lift truck.
- Load the lift truck parallel to the platform.
- Shut down the lift truck (see: 1 - OPERATING AND SAFETY INSTRUCTIONS: DRIVING INSTRUCTIONS UNLADEN AND LADEN).

**STOWING THE LIFT TRUCK**

- Fix the chocks to the platform at the front and at the back of each tyre.
- Also fix the chocks to the platform on the inside of each tyre.
- Secure the lift truck to the platform with sufficiently strong ropes. At the front of the lift truck, attach the ropes to the fastening points 1 and at the rear to the towing pin 2.
- Tighten the ropes.

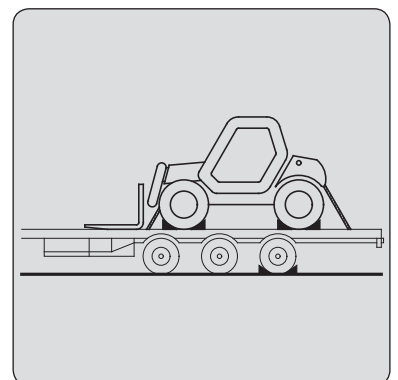
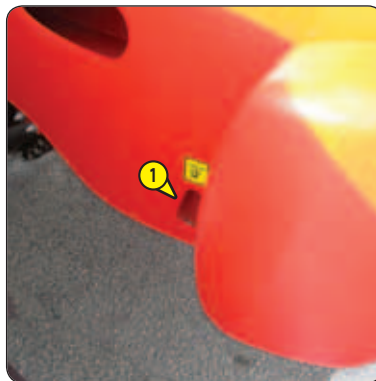
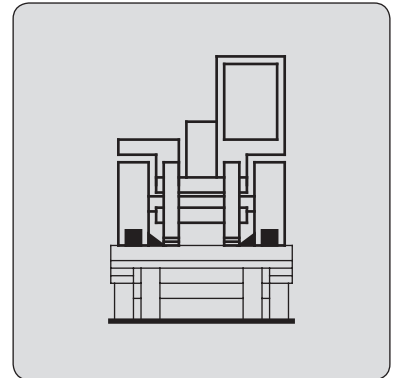
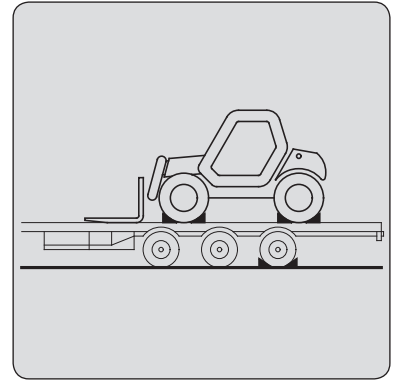



# ***4 - OPTIONAL ATTACHMENTS FOR USE WITH THE RANGE***



# TABLE OF CONTENTS

## 4 - OPTIONAL ATTACHMENTS FOR USE WITH THE RANGE

<i>INTRODUCTION</i>	<b>5</b>
<i>PICKING UP THE ATTACHMENTS</i>	<b>6</b>
<i>TECHNICAL SPECIFICATIONS OF ATTACHMENTS</i>	<b>8</b>
<i>ATTACHMENT SHIELDS</i>	<b>14</b>



## INTRODUCTION

- Your lift truck must be used with interchangeable equipment. These items are called: ATTACHMENTS.
- A wide range of attachments, specially designed and perfectly suitable for your lift truck is available and guaranteed by MANITOU.

### **⚠ IMPORTANT ⚠**

*Only attachments approved by MANITOU are to be used on our lift trucks*

*(see: 4 - ADAPTABLE ATTACHMENTS IN OPTION ON THE RANGE: TECHNICAL SPECIFICATIONS OF ATTACHMENTS).*

*The manufacturer's liability will be denied in case of modification or of attachment adaptation carried out without his knowing it.*

- The attachments are delivered with a load chart concerning your lift truck. The operator's manual and the load chart should be kept in the places provided in the lift truck. For standard attachments, their use is governed by the instructions contained on this notice.

### **⚠ IMPORTANT ⚠**

*Maximum loads are defined by the capacity of a lift truck taking account of the attachment's mass and centre of gravity.*

*In the event of the attachment having less capacity than the lift truck, never exceed this limit.*

- Some particular uses require the adaptation of the attachment which is not provided in the price-listed options. Optional solutions exist, consult your dealer.

### **⚠ IMPORTANT ⚠**

*Depending on their size, certain attachments may, when the boom is lowered and retracted, come into contact with the front tyres and cause damage to them, if reverse tilt is activated in the forward tilt direction.*

*TO REMOVE THIS RISK, EXTEND THE TELESCOPE TO A SUFFICIENT EXTENT FOR THE PARTICULAR LIFT TRUCK AND ATTACHMENT SO THAT THIS CONTACT IS NOT POSSIBLE.*

## SUSPENDED LOAD

### **⚠ IMPORTANT ⚠**

*Suspended load MUST be handled with a lift truck designed for that purpose*

*(see: 1 - OPERATING AND SAFETY INSTRUCTIONS: LOAD HANDLING INSTRUCTIONS: H - TAKING-UP AND SETTING-DOWN A SUSPENDED LOAD).*

## USE THE SINGLE SIDE-SHIFT CARRIAGE

### **⚠ IMPORTANT ⚠**

*The single side-shift carriage (TSDL) is only compatible with the following attachments:*

- floating fork carriage (TFF)
- tilting fork carriage (PFB)
- loading bucket (CBR)
- concrete bucket (BB, BBG)
- spout bucket (GL)
- crane jib and crane jib with winch (P, PT, PO, PC)
- winch (H)
- fixed platform, swivelling platform, roofer's platform.

*It is prohibited to use any other attachments on the TSDL.*

*If it is being used with a loading bucket (CBR), the single side-shift carriage MUST be centred and no side-shift operations performed.*

*Attachments authorised for use on the TSDL must comply strictly with the applications for which they are designed.*

*It is prohibited to use them for any other application (for example, earth moving, excavation, desurfacing, back scraping, etc. for the loading bucket CBR) or any application placing abnormal stress on the structure of the TSDL: risk of deformation which could cause the load to fall.*

## USE THE BUCKETS

### **⚠ IMPORTANT ⚠**

*The MT 1435/1440/1840 ..., are lift trucks essentially intended for handling. Occasional use with the buckets CBC/CBR/CB4x1 is authorised (only with the boom completely retracted, in order to reduce stress on the boom head), but under no circumstances is intensive use for difficult applications (quarry, waste, cereals, agriculture, etc) permissible. In addition, on the MT 1840 ... the back scraping is forbidden to reduce additional stress on the inner boom chains.*

## PICKING UP THE ATTACHMENTS

### 1 - ATTACHMENT WITHOUT HYDRAULICS AND HAND LOCKING DEVICE

#### TAKING UP AN ATTACHMENT

- Ensure that the attachment is in a position facilitating the locking to the carriage. If it is not correctly oriented, take the necessary precautions in order to move it safely.
- Check that the locking pin and the clip are in position in the bracket (fig. A).
- Place the lift truck with the boom fully lowered in front of and parallel to the attachment, tilt the carriage forwards (fig. B).
- Bring the carriage under the locking tube of the attachment, slightly lift the boom, incline the carriage backwards in order to position the attachment (fig. C).
- Lift the attachment off the ground to facilitate locking.

#### HAND LOCKING

- Take the locking pin and the clip on the bracket (fig. A) and lock the attachment (fig. D). Do not forget to refit the clip.

#### HAND RELEASING

- Proceed in the reverse order of paragraph HAND LOCKING while making sure you put back the locking pin and the clip in the bracket (fig. A).

#### LAYING AN ATTACHMENT

- Proceed in the reverse order of paragraph TAKING UP AN ATTACHMENT while making sure you place the attachment flat on the ground and in closed position.

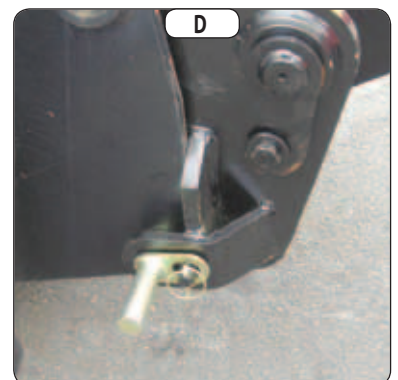
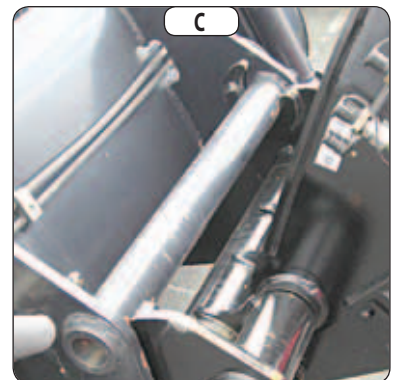
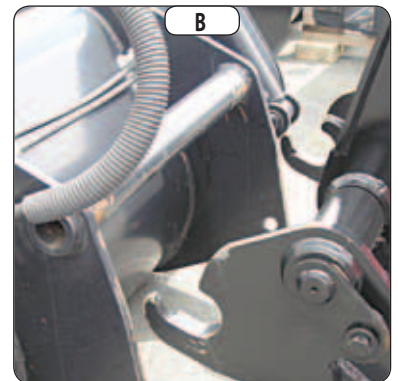
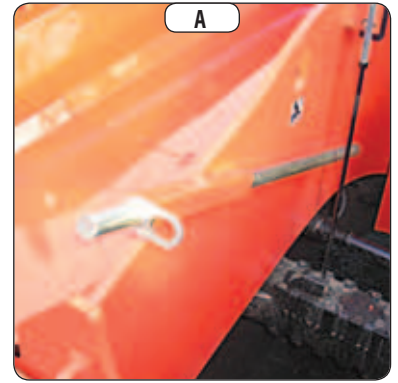

## 2 - HYDRAULIC ATTACHMENT AND MANUAL LOCKING DEVICE

### TAKING UP AN ATTACHMENT

- Ensure that the attachment is in a position facilitating the locking to the carriage. If it is not correctly oriented, take the necessary precautions in order to move it safely.
- Check that the locking pin and the clip are in position in the bracket (fig. A).
- Place the lift truck with the boom fully lowered in front of and parallel to the attachment, tilt the carriage forwards (fig. B).
- Bring the carriage under the locking tube of the attachment, slightly lift the boom, incline the carriage backwards in order to position the attachment (fig. C).
- Lift the attachment off the ground to facilitate locking.

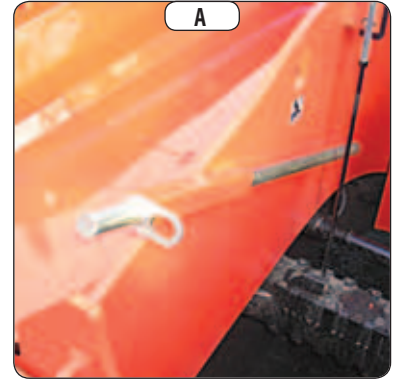



### MANUAL LOCKING AND CONNECTION OF THE ATTACHMENT

#### ⚠ IMPORTANT ⚠

*Make sure that the rapid connectors are clean and protect the holes which are not used, with the caps provided.*

- Take the locking pin and the clip on the bracket (fig. A) and lock the attachment (fig. D). Do not forget to refit the clip.
- Stop the I.C. engine and keep the ignition on the lift truck.

- Press for two seconds on the push-button  to release the attachment circuit hydraulic pressure. Screens  and  will be alternately displayed.

- Connect the rapid connectors according to the logic of the attachment's hydraulic movements.

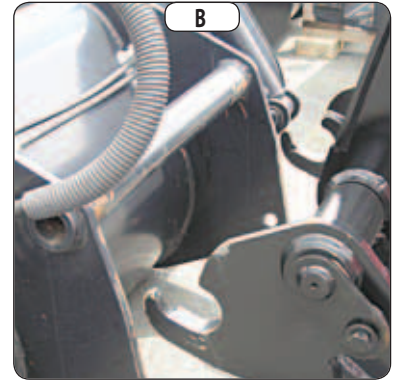

### HAND RELEASING AND DISCONNECTING THE ATTACHMENT

- Proceed in the reverse order of paragraph HAND LOCKING AND CONNECTING THE ATTACHMENT while making sure you put back the locking pin and the clip in the bracket (fig. A).

### LAYING AN ATTACHMENT

- Proceed in the reverse order of paragraph TAKING UP AN ATTACHMENT while making sure you place the attachment flat on the ground and in closed position.

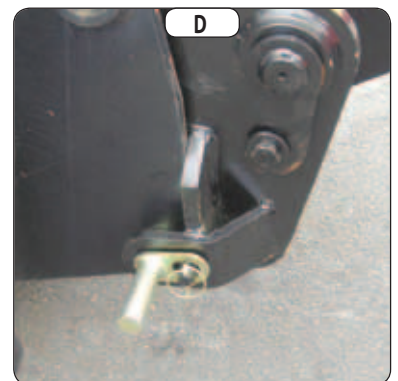
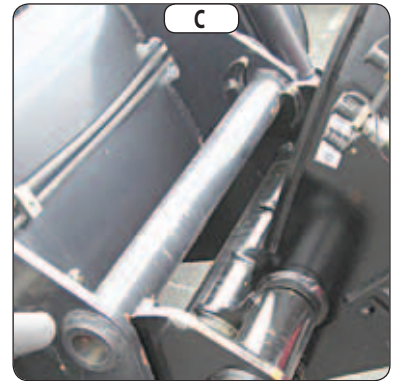

## TECHNICAL SPECIFICATIONS OF ATTACHMENTS

### FLOATING FORK CARRIAGE

MT 1435 ...

REFERENCE	TFF 35 MT-1040	TFF 35 MT-1300
Rated capacity	654093 3500 kg	654094 3500 kg
Width	1040 mm	1300 mm
Weight	300 kg	325 kg

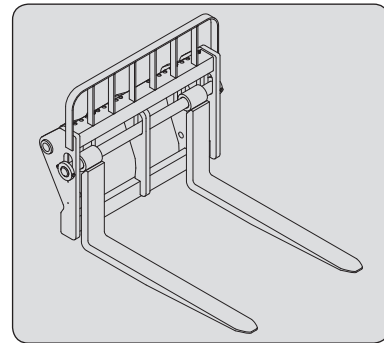

### FLOATING FORK

MT 1435 ...

REFERENCE	415801
Section	125x45x1200 mm
Weight	68 kg

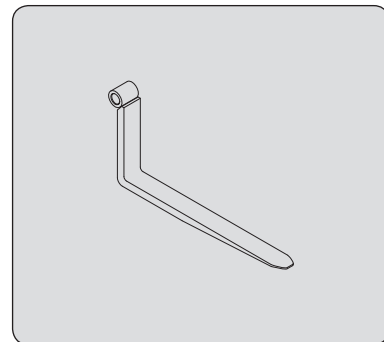

### FLOATING FORK CARRIAGE

MT 1440/1840 ...

REFERENCE	TFF 45 MT-1040	TFF 45 MT-1300
Rated capacity	653344 4500 kg	653345 4500 kg
Width	1040 mm	1300 mm
Weight	370 kg	400 kg

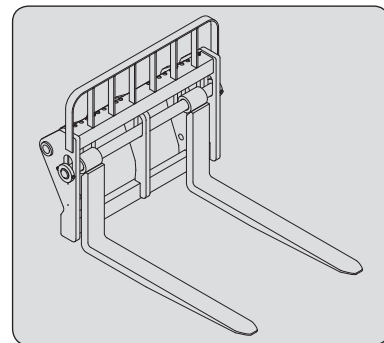

### FLOATING FORK

MT 1440/1840 ...

REFERENCE	211922
Cross sectional area	125x50x1200 mm
Weight	71 kg

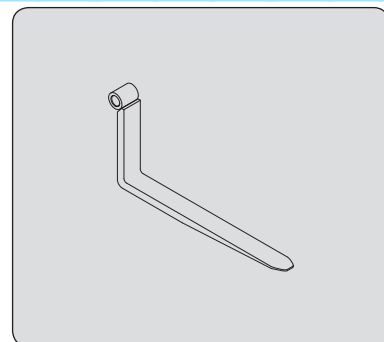



### STANDARDIZED TILTING FORK CARRIAGE

REFERENCE	PFB 45 N MT-1260 S2 654407	PFB 45 N MT-1670 S2 653747	PFB 45 N MT-2000 S2 653748
Rated capacity	4500 kg	4500 kg	4500 kg
Width	1260 mm	1670 mm	2000 mm
Weight	200 kg	255 kg	300 kg

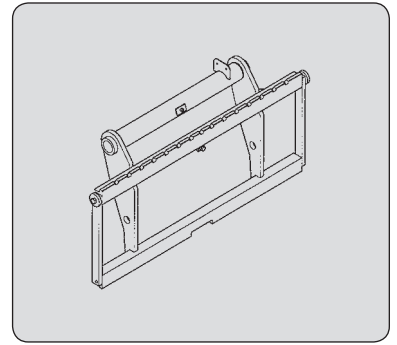

### STANDARDISED FORK

REFERENCE	415652
Section	125x50x1200 mm
Weight	78 kg

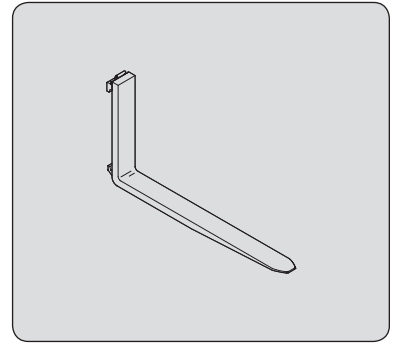

### STANDARDIZED TILTING FORK CARRIAGE + STANDARDIZED SIDE-SHIFT CARRIAGE

*Use is prohibited with the optional single side-shift carriage (TSDL).*

REFERENCE	PFB 45 N 1670 DL 52000103
Rated capacity	4300 kg
Side-shift	2x100 mm
Width	1670 mm
Weight	530 kg

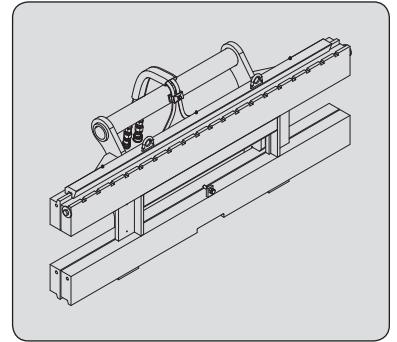

### STANDARDIZED TILTING FORK CARRIAGE + LOAD BACK REST

REFERENCE	PFB 45 N 1670 LB 52000202	PFB 45 N 2000 LB 52000203
Rated capacity	4500 kg	4500 kg
Width	1670 mm	2000 mm
Weight	310 kg	360 kg

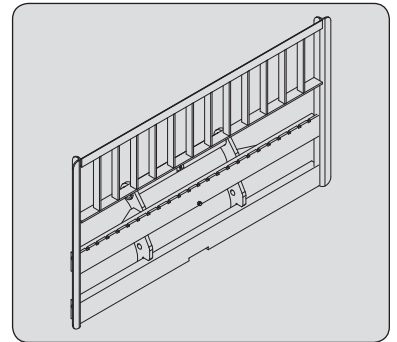

### STANDARDIZED TILTING FORK CARRIAGE + STANDARDIZED SIDE-SHIFT CARRIAGE + LOAD BACK REST

*Use is prohibited with the optional single side-shift carriage (TSDL).*

REFERENCE	PFB 45 N 1670 DL/LB 52000206
Rated capacity	4300 kg
Side-shift	2x100 mm
Width	1670 mm
Weight	585 kg

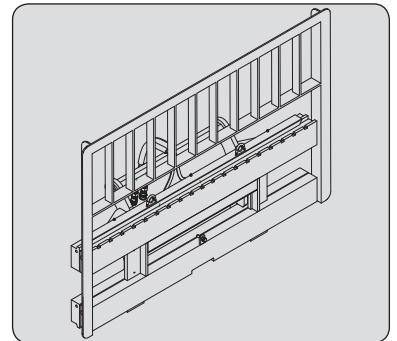

## BUILDING BUCKET

REFERENCE	CBC 800 L2250 S3 654471	CBC 900 L2450 S3 654470
Rated capacity	814 l	893 l
Width	2250 mm	2450 mm
Weight	385 kg	410 kg

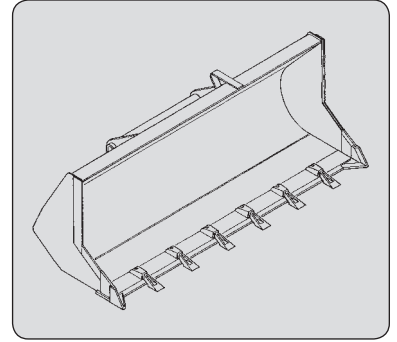

## LOADING BUCKET

REFERENCE	CBR 900 L2250 S2 653749	CBR 1000 L2450 S2 654716
Rated capacity	904 l	990 l
Width	2250 mm	2450 mm
Weight	390 kg	410 kg

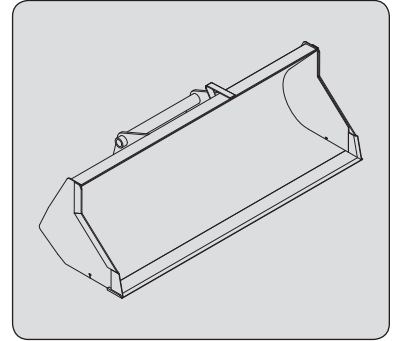

## BENNE 4X1

MT 1435/1440 ...

*Use is prohibited with the optional single side-shift carriage (TSDL).*

REFERENCE	CB4X1-700 L1950 751402	CB4X1-850 L2300 751401	CB4X1-900 L2450 751465
Rated capacity	700 l	850 l	900 l
Width	1950 mm	2300 mm	2450 mm
Weight	640 kg	735 kg	765 kg

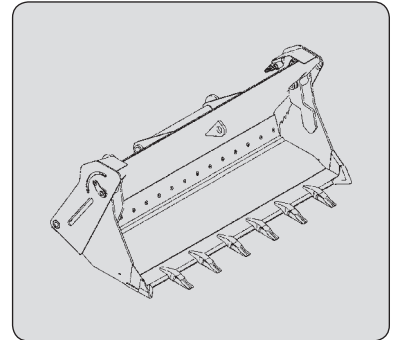

### CONCRETE BUCKET (ADAPTABLE ON FORKS)

REFERENCE	BB 500 S4 654409	BBH 500 S4 751462
Rated capacity	500 l/1300 kg	500 l/1300 kg
Width	1100 mm	1100 mm
Weight	205 kg	220 kg

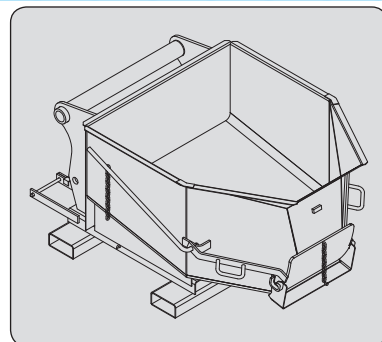

### CONCRETE BUCKET WITH SPOUT (ADAPTABLE ON FORKS)

MT 1435/1440 ...

REFERENCE	BBG 500 S4 654411	BBHG 500 S4 751464
Rated capacity	500 l/1300 kg	500 l/1300 kg
Width	1100 mm	1100 mm
Weight	220 kg	235 kg

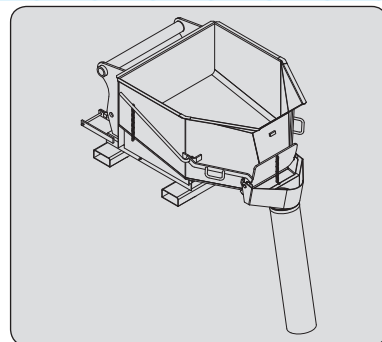

### MIXER BUCKET

REFERENCE	MBM 500 757637
Rated capacity	300 l
Weight	753 kg

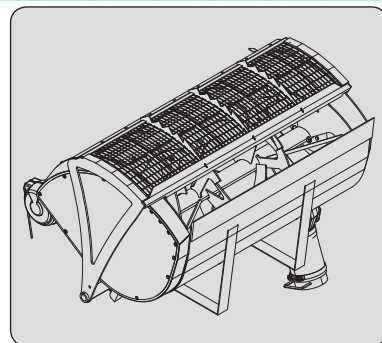

**BOOM CRANE**

	<b>P 600 MT S3</b>
<b>REFERENCE</b>	<b>653228</b>
Rated capacity	600 kg
Weight	170 kg

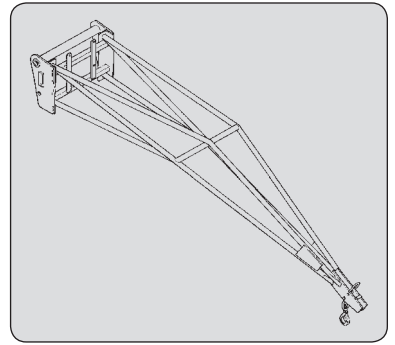

**BOOM CRANE**

	<b>P 4000 MT S2</b>
<b>REFERENCE</b>	<b>653226</b>
Rated capacity	4000 kg/1200 kg
Weight	210 kg

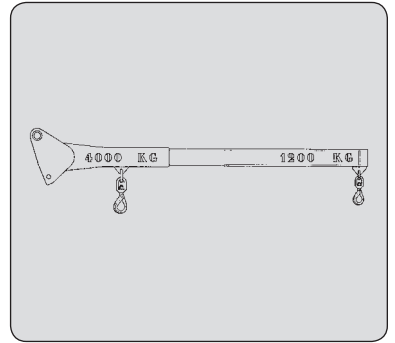

**CRANE JIB WITH WINCH**

	<b>PT 600 MT S6</b>
<b>REFERENCE</b>	<b>708538</b>
Rated capacity	600 kg
Weight	288 kg

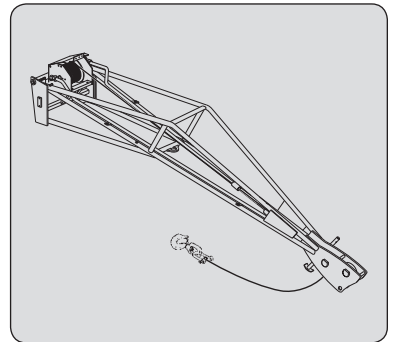

**15°/15° MULTI-DIRECTIONAL CRANE JIB**

	<b>PO 600 L2500</b>	<b>PO 1000 L1500</b>	<b>PO 2000 L1000</b>
<b>REFERENCE</b>	<b>784641</b>	<b>784642</b>	<b>784643</b>
Rated capacity	600 kg	1000 kg	2000 kg
Weight	320 kg	275 kg	255 kg

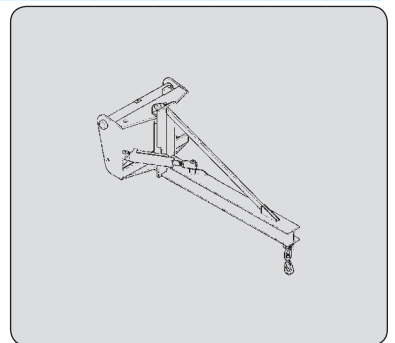

**BOOM CRANE**

	<b>PC 50</b>
<b>REFERENCE</b>	<b>708544</b>
Rated capacity	5000 kg
Weight	120 kg

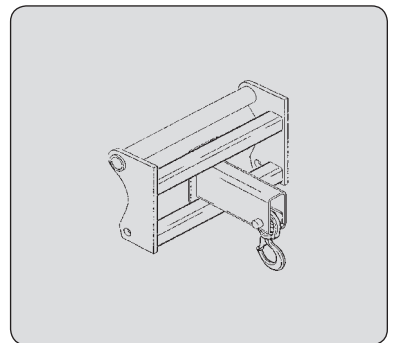

## BOOM CRANE

<b>REFERENCE</b>	<b>JE 6000/600</b> <b>939995</b>
Rated capacity	600 kg
Weight	182 kg

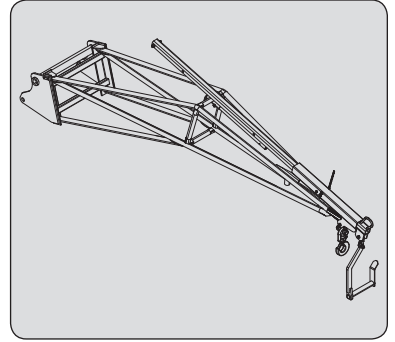

## BOOM CRANE WITH BIG BAG

<b>REFERENCE</b>	<b>HBB 1500/2400</b> <b>931627</b>
Rated capacity	2400 kg
Weight	186 kg

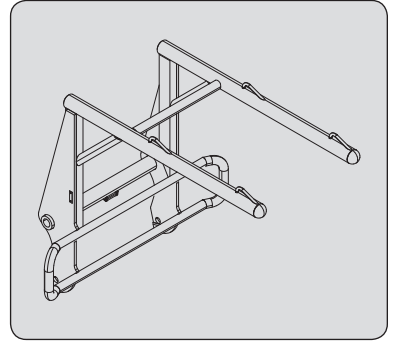

## POSITIONING THE EDGE

<b>REFERENCE</b>	<b>PBA</b> <b>790523</b>
Rated capacity	1500 kg
Weight	450 kg

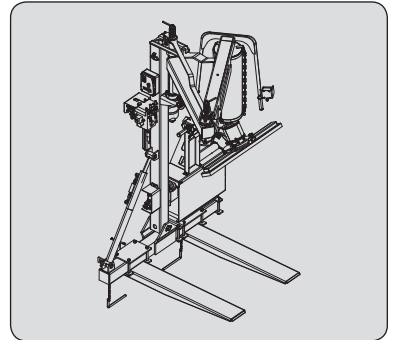

# ATTACHMENT SHIELDS

## FORK PROTECTOR

PART NUMBER 227801

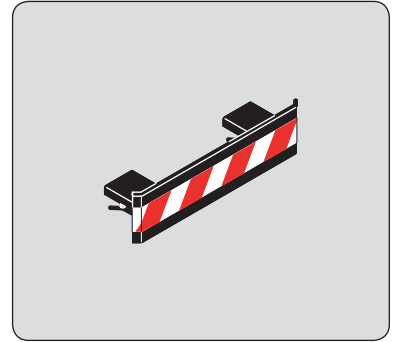

## FORK BLOCK FOR FLOATING FORK CARRIAGE

PART NUMBER 261210

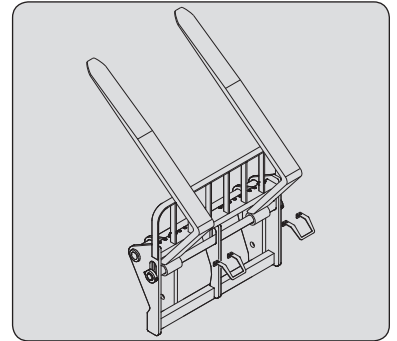

## BUCKET PROTECTOR

*Always ensure that the width of the protector you choose is less than or equal to the width of the bucket.*

	<b>PART NUMBER</b>	<b>206734</b>	<b>206732</b>	<b>206730</b>
Width		1375 mm	1500 mm	1650 mm
	<b>PART NUMBER</b>	<b>235854</b>	<b>206728</b>	<b>206726</b>
Width		1850 mm	1950 mm	2000 mm
	<b>PART NUMBER</b>	<b>223771</b>	<b>223773</b>	<b>206724</b>
Width		2050 mm	2100 mm	2150 mm
	<b>PART NUMBER</b>	<b>206099</b>	<b>206722</b>	<b>223775</b>
Width		2250 mm	2450 mm	2500 mm

